

# 11 Gauge Gabions

## Materials

### Wire Mesh

Opening	3" x 3"
Diameter	11 Gauge (0.120")
Galvanized	0.8 oz / ft <sup>2</sup>
Tensile Strength	60,000 psi min.
Weld Shear Strength	450 ft-lbs

### Spiral Wire

Diameter	11 Gauge (0.120")
Galvanized	0.8 oz / ft <sup>2</sup>
Tensile Strength	60,000 psi min.

### Lacing Wire

Diameter	13.5 Gauge (0.087")
Galvanized	0.8 oz / ft <sup>2</sup>
Tensile Strength	60,000 psi min.

Preformed Stiffeners	11 Gauge (0.120")
----------------------	-------------------

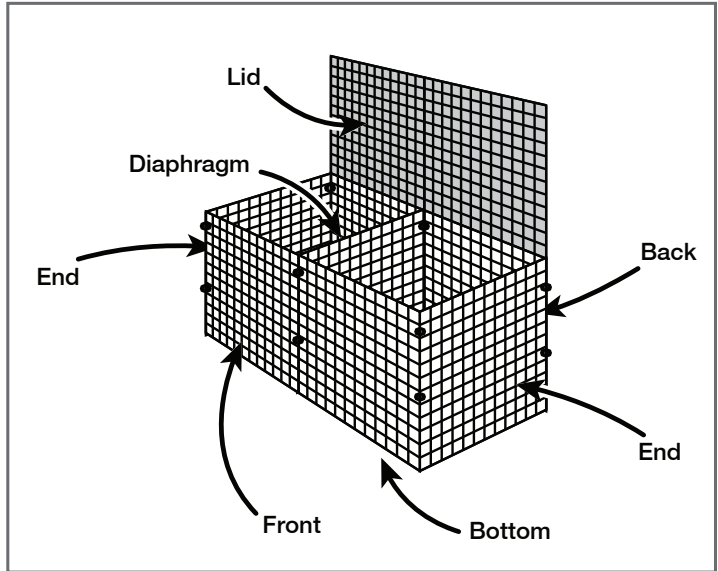

## Fabrication

In accordance with ASTM A974, Lane gabions are manufactured with all panels mechanically connected at the production facility. They are supplied in collapsed form and stacked in bundles for easy job site assembly. Where the length of the gabion exceeds the width, the length is divided equally into cells using diaphragm panels so that each cell is no greater than one cubic yard. Each Lane gabion is supplied with enough accessories (vertical spirals, temporary fasteners, lacing wire, and preformed stiffeners (3' high baskets only)) to completely assemble and install, with minimal tools required. See gabion and mattress installation guide for details. In addition, all Lane gabions are made from materials made in the USA.

Standard 11 Gauge Gabion Sizes			
Size	Cells	Capacity (cu. yds.)	Weight (lbs.)
3' x 3' x 3'	1	1	24
6' x 3' x 3'	2	2	42
9' x 3' x 3'	3	3	60
12' x 3' x 3'	4	4	78
3' x 3' x 1.5'	1	0.5	17
6' x 3' x 1.5'	2	1	29
9' x 3' x 1.5'	3	1.5	42
12' x 3' x 1.5'	4	2	54
3' x 3' x 1'	1	0.33	15
6' x 3' x 1'	2	0.66	25
9' x 3' x 1'	3	1	36
12' x 3' x 1'	4	1.33	47

For more information about Lane's Welded Wire Mesh Gabion & Gabion Mattresses, visit: [lane-enterprises.com](http://lane-enterprises.com).