

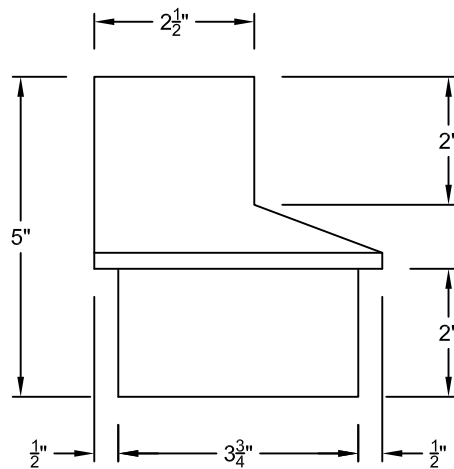

TOP VIEW



SIDE VIEW

NOTE: ALL FITTING DIMENSIONS ARE FOR REFERENCE ONLY.

File Name:	HDFT04SDSA/C	LANE ENTERPRISES, INC.	
Page Number:	1 OF 1	2"x3"x4" DOWNSPOUT ADAPTER	
Date Drawn:	4-17-14		
Drawn By:	JDS		

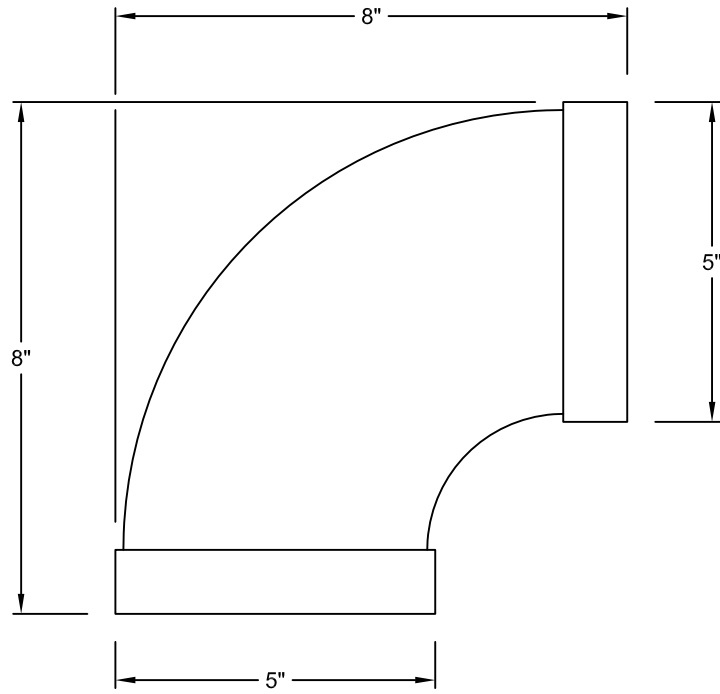

SIDE VIEW

NOTE: ALL FITTING DIMENSIONS ARE FOR REFERENCE ONLY.

File Name:	HDFT04EL90/C	LANE ENTERPRISES, INC.	
Page Number:	1 OF 1	4" 90° ELBOW	
Date Drawn:	4-16-14		
Drawn By:	JDS		

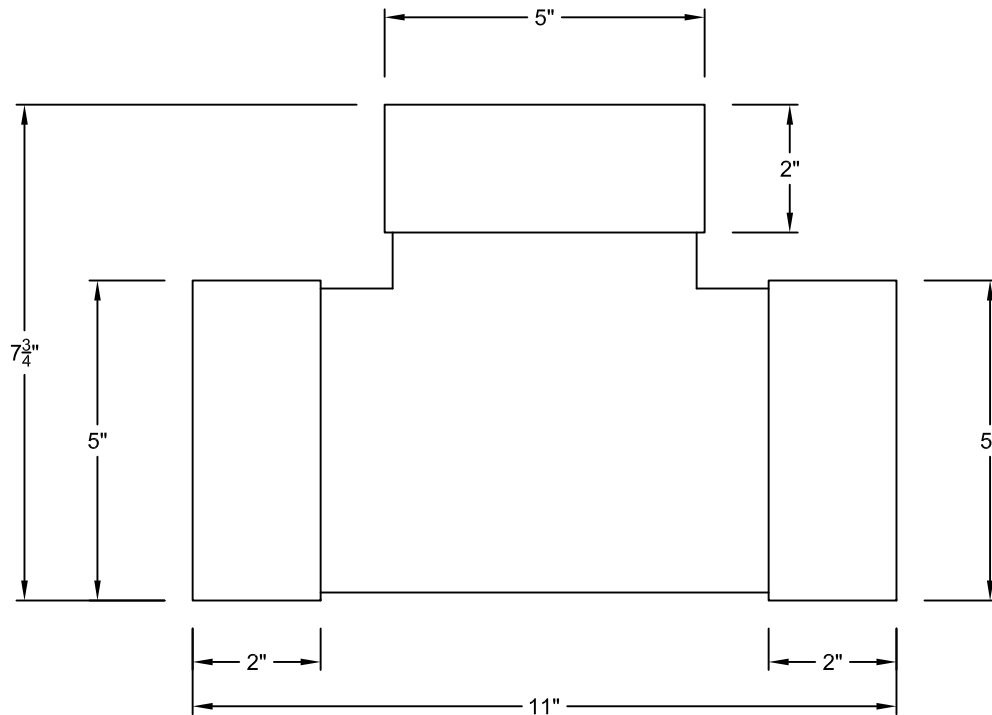

SIDE VIEW

NOTE: ALL FITTING DIMENSIONS ARE FOR REFERENCE ONLY.

File Name:	HDFT04T/C	LANE ENTERPRISES, INC.	
Page Number:	1 OF 1	4" TEE	
Date Drawn:	4-16-14		
Drawn By:	JDS		

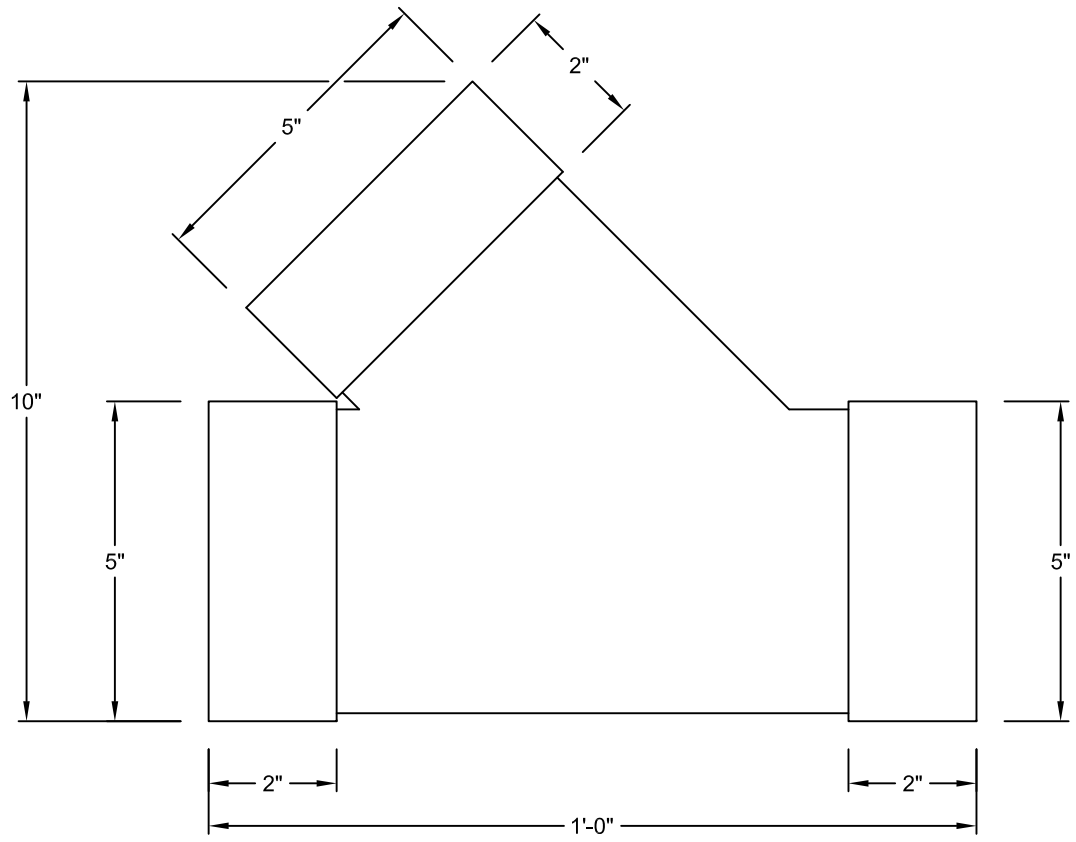

SIDE VIEW

NOTE: ALL FITTING DIMENSIONS ARE FOR REFERENCE ONLY.

File Name:	HDFT04W/C	LANE ENTERPRISES, INC.
Page Number:	1 OF 1	4" WYE
Date Drawn:	4-16-14	
Drawn By:	JDS	



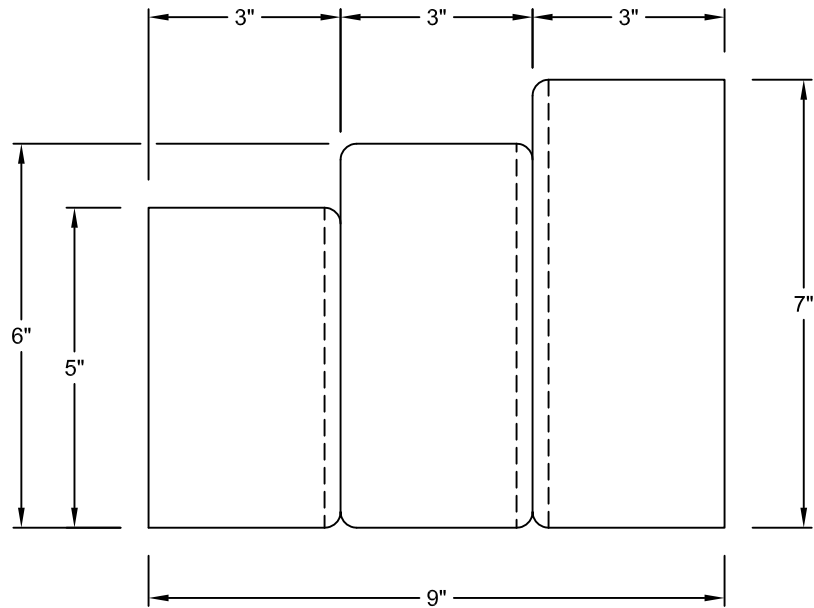

SIDE VIEW

NOTE: ALL FITTING DIMENSIONS ARE FOR REFERENCE ONLY.

File Name:	HDCP06RSC	LANE ENTERPRISES, INC.	
Page Number:	1 OF 1		
Date Drawn:	4-17-14	6" REDUCER SNAP COUPLER	
Drawn By:	JDS		

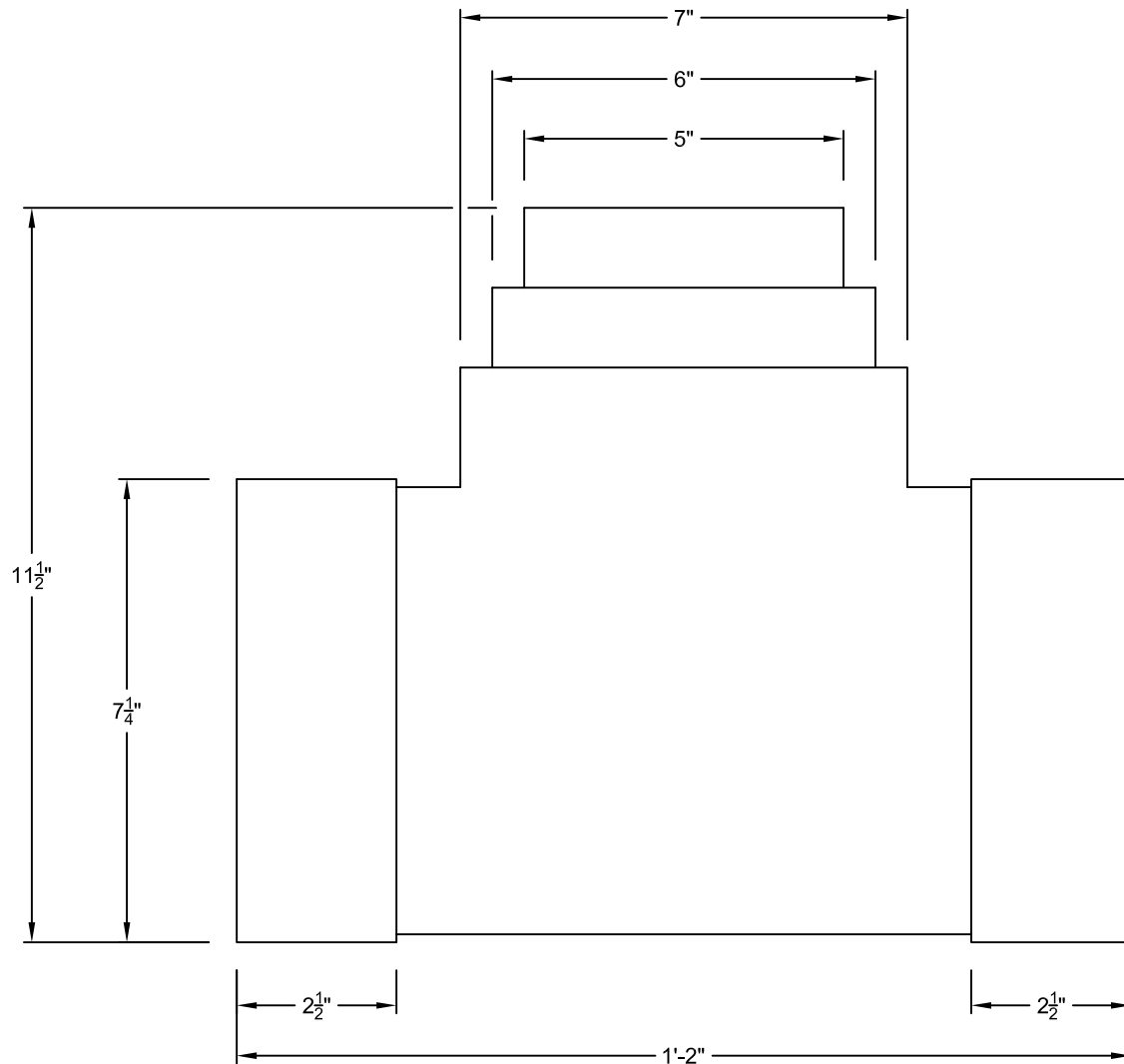

TOP VIEW

NOTE: ALL FITTING DIMENSIONS ARE FOR REFERENCE ONLY.

File Name:	HDFT06RT/C	LANE ENTERPRISES, INC.
Page Number:	1 OF 1	6" REDUCER TEE
Date Drawn:	4-17-14	
Drawn By:	JDS	



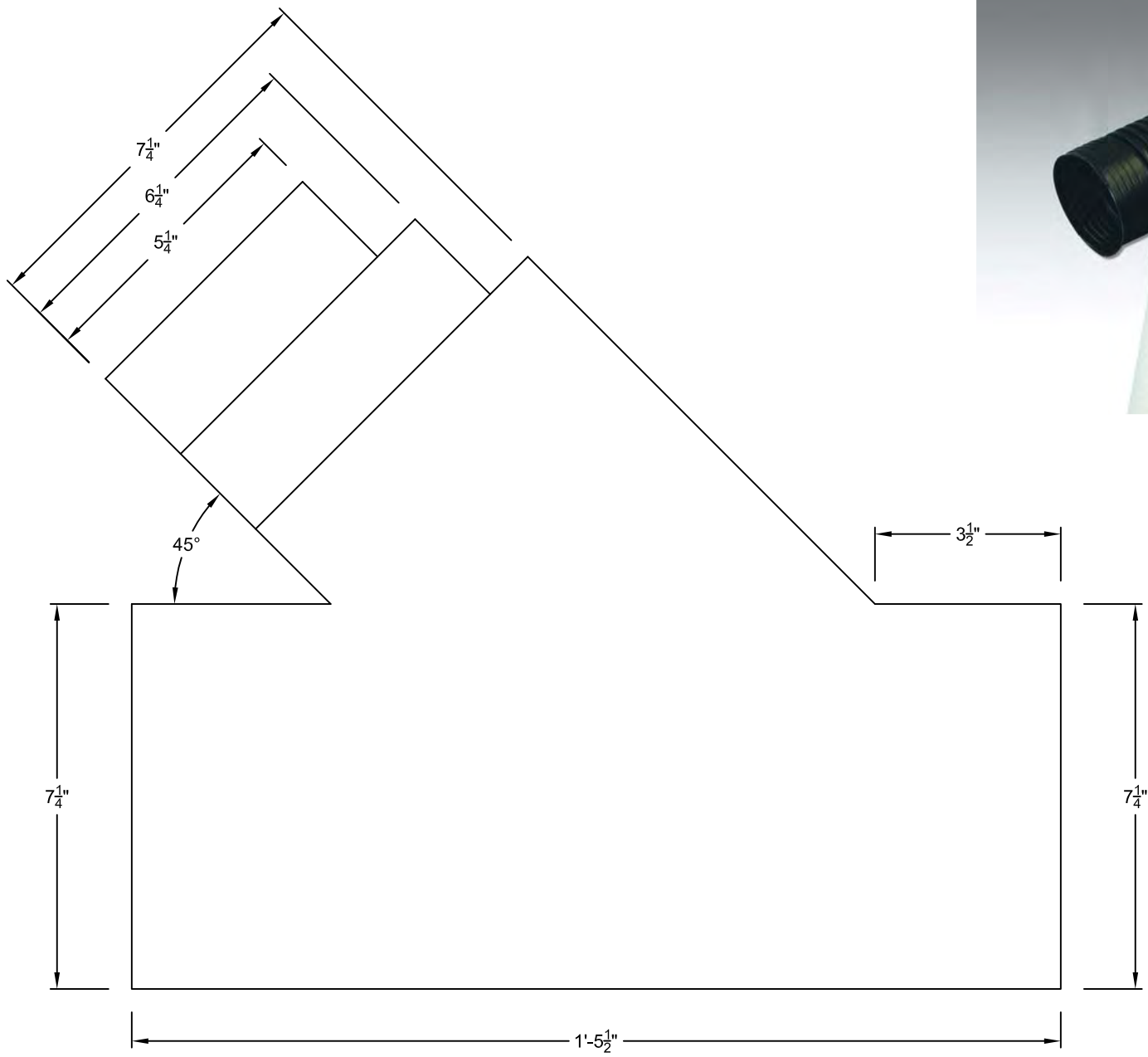

**SIDE VIEW**

NOTE: ALL FITTING DIMENSIONS ARE FOR REFERENCE ONLY.

File Name:	HDFT06RW/C	LANE ENTERPRISES, INC.
Page Number:	1 OF 1	
Date Drawn:	4-17-14	
Drawn By:	JDS	
		6" REDUCER WYE



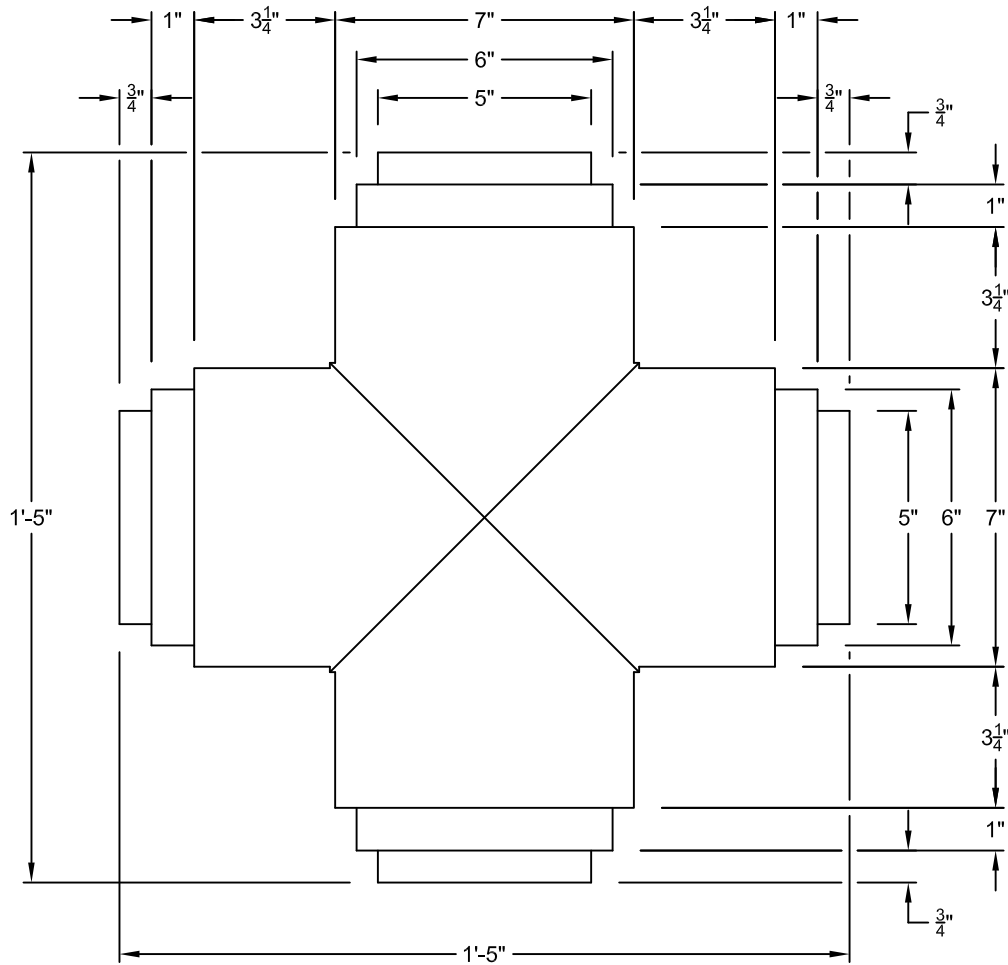

TOP VIEW

NOTE: ALL FITTING DIMENSIONS ARE FOR REFERENCE ONLY.



File Name:	HDFT06RCT/C	LANE ENTERPRISES, INC.  6" REDUCING CROSS TEE
Page Number:	1 OF 1	
Date Drawn:	4-17-14	
Drawn By:	JDS	



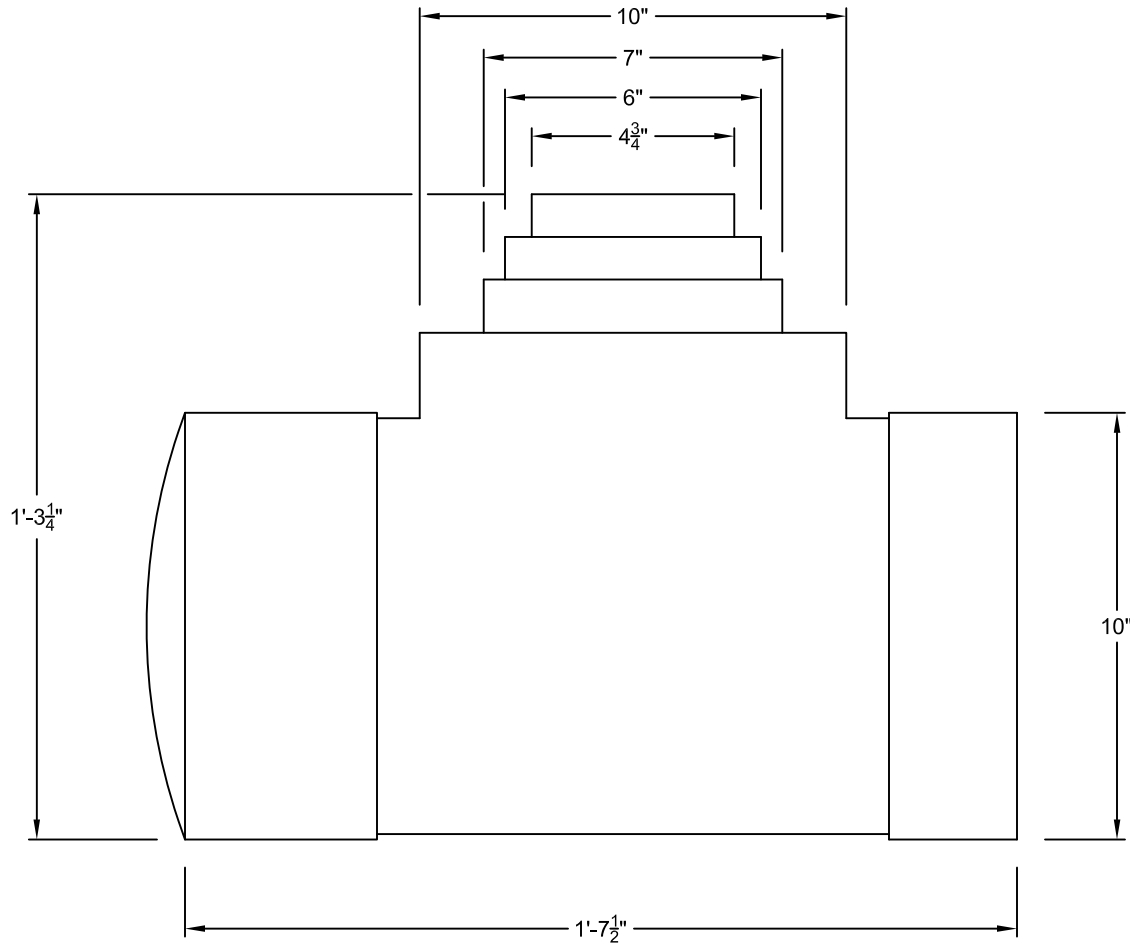

TOP VIEW

NOTE: ALL FITTING DIMENSIONS ARE FOR REFERENCE ONLY.

File Name:	HDFT08BRT/C	LANE ENTERPRISES, INC.  6" BLIND REDUCING TEE
Page Number:	1 OF 1	
Date Drawn:	4-17-14	
Drawn By:	JDS	



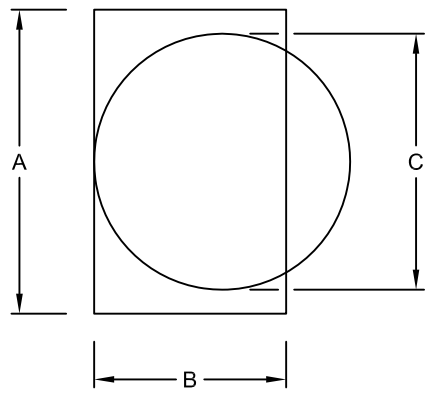

TOP VIEW

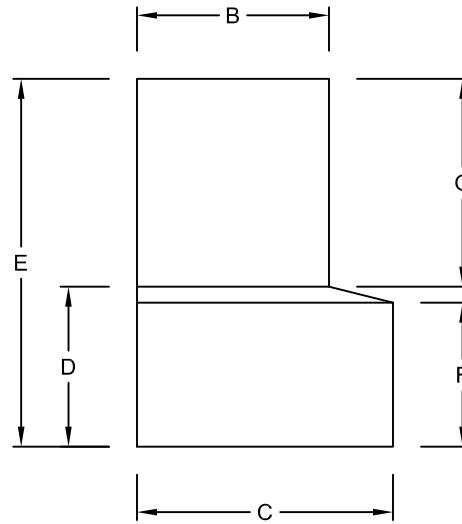

SIDE VIEW

PIPE SIZE	PART #	A	B	C	D	E	F	G
4"	<a href="#">HDFT04LDSA/C</a>	7.75	3.00"	4.00"	2.50"	5.75"	2.25"	3.25"
6"	<a href="#">HDFT06DSA/C</a>	6.50"	4.50"	5.50"	3.25"	8.25"	4.00"	5.00"

NOTE: ALL FITTING DIMENSIONS ARE FOR REFERENCE ONLY.

File Name:	XX	LANE ENTERPRISES, INC.  DOWNSPOUT ADAPTER
Page Number:	1 OF 1	
Date Drawn:	4-17-14	
Drawn By:	JDS	



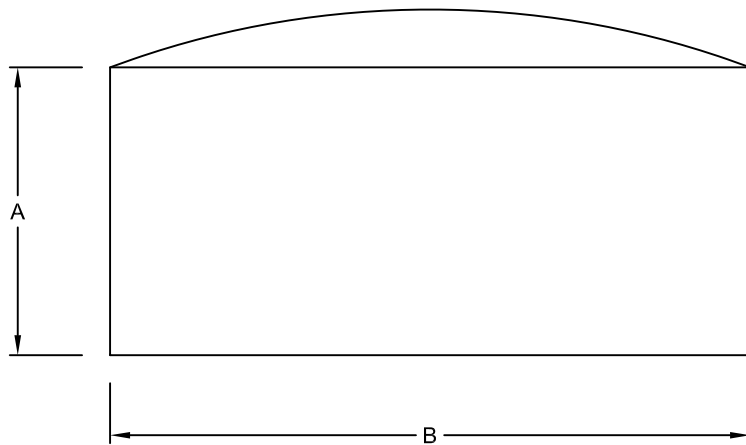

**SIDE VIEW**

PIPE SIZE	PART #	A	B
4"	<a href="#">HDFT04EC/C</a>	2.00"	5.50"
6"	<a href="#">HDFT06EC/C</a>	3.00"	7.50"
8"	<a href="#">HDFT08EC/C</a>	4.50"	10.00"

NOTE: ALL FITTING DIMENSIONS ARE FOR REFERENCE ONLY.

File Name:	XX	LANE ENTERPRISES, INC.  END CAP
Page Number:	1 OF 1	
Date Drawn:	4-17-14	
Drawn By:	JDS	



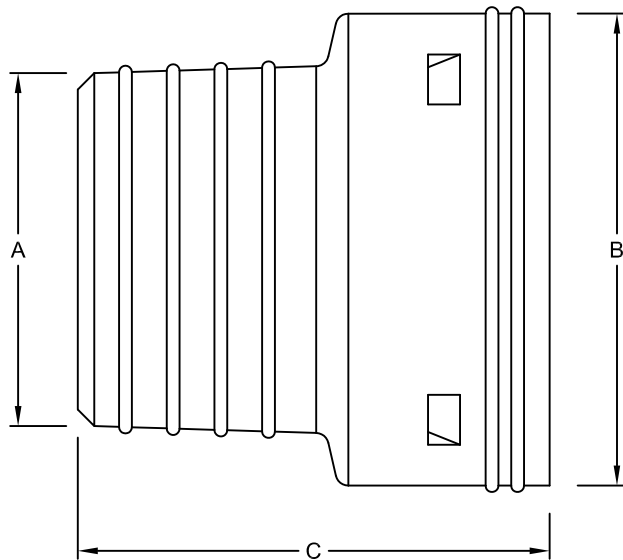

TOP VIEW



PIPE SIZE	PART #	A	B	C
4"	<a href="#">HDFT-4-CA/C</a>	3.75"	5.125"	4.375"
6"	<a href="#">HDFT-6-CA/C</a>	5.50"	7.375"	6.75"
8"	<a href="#">HDFT-8-CA/C</a>	7.50"	10.125"	9.50"

NOTE: ALL FITTING DIMENSIONS ARE FOR REFERENCE ONLY.

File Name:	XX	<b>LANE ENTERPRISES, INC.</b>  HAVILAND HDPE TO PVC / CLAY ADAPTER	
Page Number:	1 OF 1		
Date Drawn:	5-18-14		
Drawn By:	JDS		

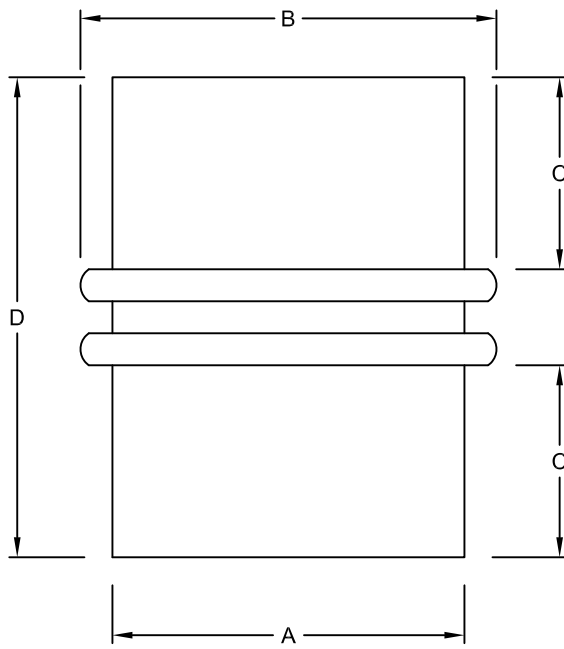

TOP VIEW



PIPE SIZE	PART #	A	B	C	D
4"	<a href="#">HDCP04IC</a>	3.875"	4.50"	2.625"	6.50"
6"	<a href="#">HDCP06IC</a>	5.5"	6.50"	3.00"	7.50"
8"	<a href="#">HDCP08IC</a>	7.75"	9.00"	3.50"	8.50"

NOTE: ALL FITTING DIMENSIONS ARE FOR REFERENCE ONLY.

File Name:	XX	LANE ENTERPRISES, INC.	
Page Number:	1 OF 1		
Date Drawn:	4-17-14	HAVILAND INTERNAL COUPLER	
Drawn By:	JDS		

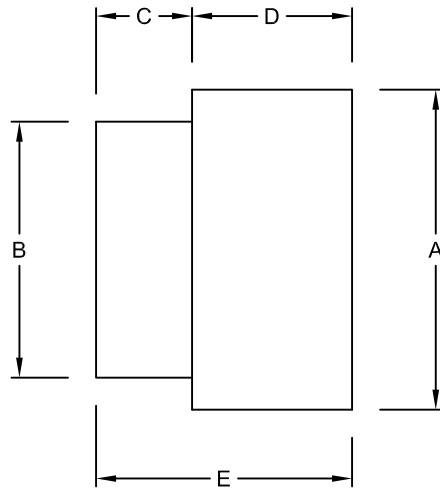

TOP VIEW



PIPE SIZE	FOR SIZES	PART #	A	B	C	D	E
4"	6"-8"	<a href="#">HDFT04STT/C</a>	5.00"	4.00"	1.25"	2.25"-3.00"	4.00"-4.25"
4"	10"-12"	<a href="#">HDFT04LTT/C</a>	5.00"	4.00"	2.00"	3.00"-3.50"	5.00"-5.50"
6"	15"-24"	<a href="#">HDFT06STT/C</a>	7.50"	6.50"	3.00"	3.00"-3.75"	6.00"
6"	30"-36"	<a href="#">HDFT06LTT/C</a>	7.50"	6.50"	3.00"	3.00"-3.75"	6.00"

NOTE: ALL FITTING DIMENSIONS ARE FOR REFERENCE ONLY.

File Name:	XX	LANE ENTERPRISES, INC.  LARGE & SMALL TAP TEE
Page Number:	1 OF 1	
Date Drawn:	4-17-14	
Drawn By:	JDS	



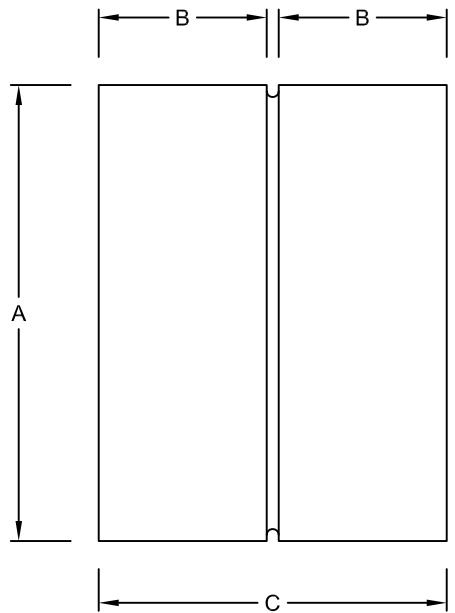

TOP VIEW



PIPE SIZE	PART #	A	B	C
4"	<a href="#">HDCP04SC</a>	5.00"	2.00"	4.25"
6"	<a href="#">HDCP06SC</a>	7.25"	3.00"	7.25"
8"	<a href="#">HDCP08SC</a>	9.50"	3.50"	7.25"
10"	<a href="#">HDCP10SC</a>	11.75"	4.75"	10.50"
12"	<a href="#">HDCP12SC</a>	14.75"	6.25"	13.25"

NOTE: ALL FITTING DIMENSIONS ARE FOR REFERENCE ONLY.

File Name:	XX	LANE ENTERPRISES, INC.  SNAP COUPLER
Page Number:	1 OF 1	
Date Drawn:	4-16-14	
Drawn By:	JDS	



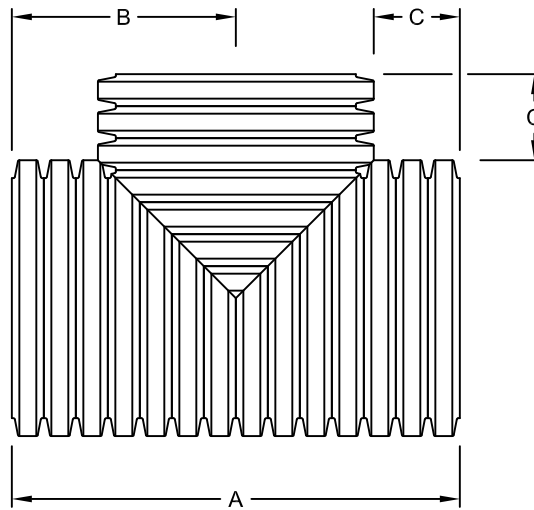

TOP VIEW

PIPE SIZE	PART #	A	B	C
4"	<a href="#">HDFT04T/S</a>	7.75"	4.00"	1.50"
6"	<a href="#">HDFT06T/S</a>	12.50"	6.25"	2.75"
8"	<a href="#">HDFT08T/S</a>	15.50"	7.75"	3.00"
10"	<a href="#">HDFT10T/S</a>	18.50"	9.25"	3.25"
12"	<a href="#">HDFT12T/S</a>	23.50"	11.75"	4.50"
15"	<a href="#">HDFT15T/S</a>	31.00"	15.50"	6.75"
18"	<a href="#">HDFT18T/S</a>	35.50"	17.75"	7.00"
24"	<a href="#">HDFT24T/S</a>	47.25"	23.50"	9.75"
30"	<a href="#">HDFT30T/S</a>	56.00"	28.00"	10.75"
36"	<a href="#">HDFT36T/S</a>	64.00"	32.00"	11.50"
42"	<a href="#">HDFT42T/S</a>	74.75"	37.25"	13.50"
48"	<a href="#">HDFT48T/S</a>	74.75"	37.25"	10.00"
60"	<a href="#">HDFT60T/S</a>	90.00"	45.00"	11.75"

NOTE: ALL FITTING DIMENSIONS ARE FOR REFERENCE ONLY.

File Name:	P1050
Page Number:	1 OF 1
Date Drawn:	5-9-09
Drawn By:	JCH

LANE ENTERPRISES, INC.

SINGLE TEE



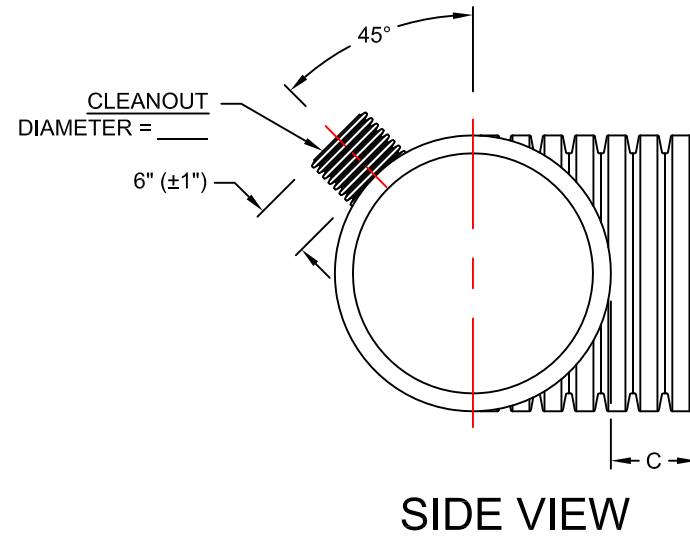
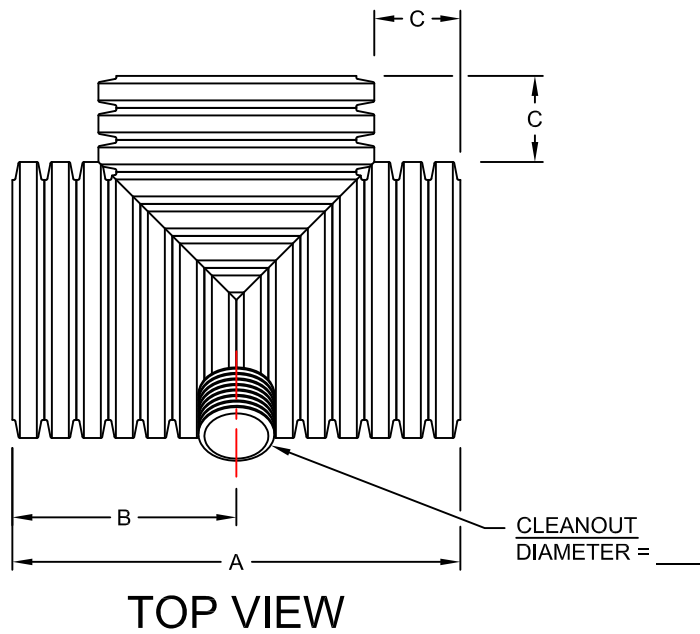

PIPE SIZE	PART #	A	B	C
12"	XX	23.50"	11.75"	4.50"
15"	XX	31.00"	15.50"	6.75"
18"	XX	35.50"	17.75"	7.00"
24"	XX	47.25"	23.50"	9.75"
30"	XX	56.00"	28.00"	10.75"
36"	XX	64.00"	32.00"	11.50"
42"	XX	74.75"	37.25"	13.50"
48"	XX	74.75"	37.25"	10.00"
60"	XX	90.00"	45.00"	11.75"

NOTE: ALL FITTING DIMENSIONS ARE FOR REFERENCE ONLY.

File Name:	XX	<b>LANE ENTERPRISES, INC.</b>  SINGLE TEE WITH CLEANOUT
Page Number:	1 OF 1	
Date Drawn:	10-9-15	
Drawn By:	JDS	



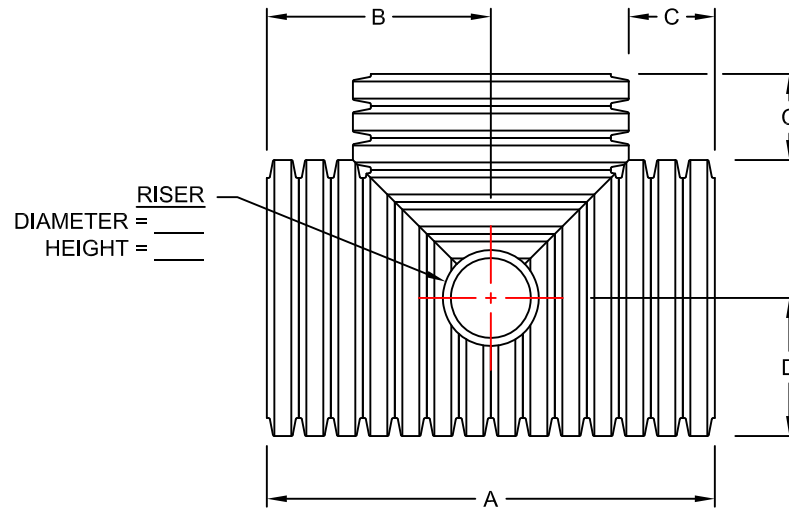

TOP VIEW

PIPE SIZE	PART #	A	B	C	D
12"	XX	23.50"	11.75"	4.50"	7.25"
15"	XX	31.00"	15.50"	6.75"	8.75"
18"	XX	35.50"	17.75"	7.00"	10.75"
24"	XX	47.25"	23.50"	9.75"	14.00"
30"	XX	56.00"	28.00"	10.75"	17.25"
36"	XX	64.00"	32.00"	11.50"	20.50"
42"	XX	74.75"	37.25"	13.50"	23.75"
48"	XX	74.75"	37.25"	10.00"	27.25"
60"	XX	90.00"	45.00"	11.75"	33.25"

NOTE: ALL FITTING DIMENSIONS ARE FOR REFERENCE ONLY.

File Name:	XX	<b>LANE ENTERPRISES, INC.</b>  SINGLE TEE WITH RISER
Page Number:	1 OF 1	
Date Drawn:	10-9-15	
Drawn By:	JDS	



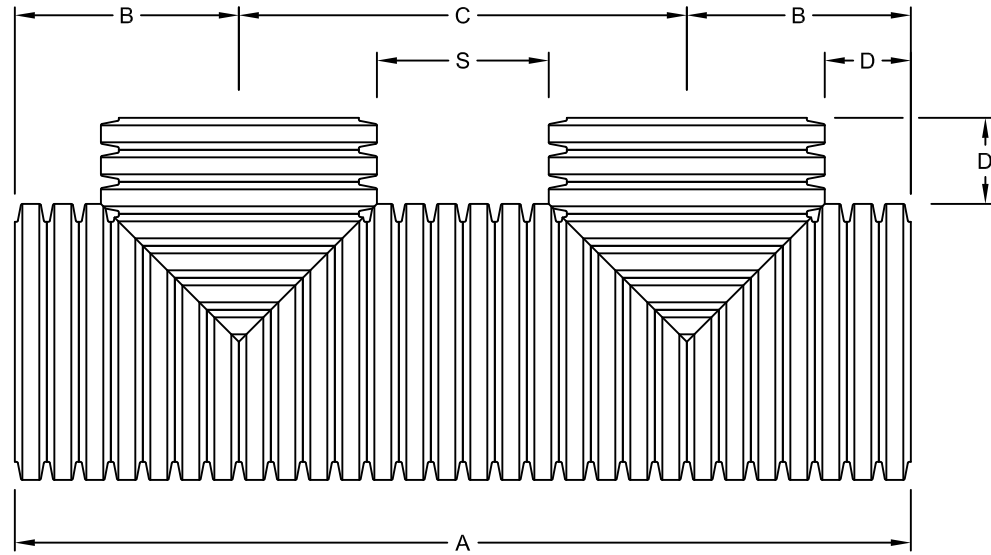

TOP VIEW

PIPE SIZE	PART #	A	B	C	D	S
12"	<a href="#">HDFT12TX2/S</a>	47.25"	11.75"	23.50"	4.50"	9.00"
15"	<a href="#">HDFT15TX2/S</a>	62.00"	15.50"	31.00"	6.75"	13.50"
18"	<a href="#">HDFT18TX2/S</a>	71.00"	17.75"	35.50"	7.00"	14.00"
24"	<a href="#">HDFT24TX2/S</a>	94.50"	23.50"	47.25"	9.75"	19.25"
30"	<a href="#">HDFT30TX2/S</a>	112.00"	28.00"	56.00"	10.75"	21.50"
36"	<a href="#">HDFT36TX2/S</a>	128.00"	32.00"	64.00"	11.50"	23.00"
42"	<a href="#">HDFT42TX2/S</a>	149.25"	37.25"	74.75"	13.50"	27.25"
48"	<a href="#">HDFT48TX2/S</a>	149.25"	37.25"	74.75"	10.00"	20.25"
60"	<a href="#">HDFT60TX2/S</a>	180.00"	45.00"	90.00"	11.75"	23.25"

NOTE: ALL FITTING DIMENSIONS ARE FOR REFERENCE ONLY.

File Name:	P1100	<b>LANE ENTERPRISES, INC.</b>  DOUBLE TEE
Page Number:	1 OF 1	
Date Drawn:	10-9-15	
Drawn By:	JCH	



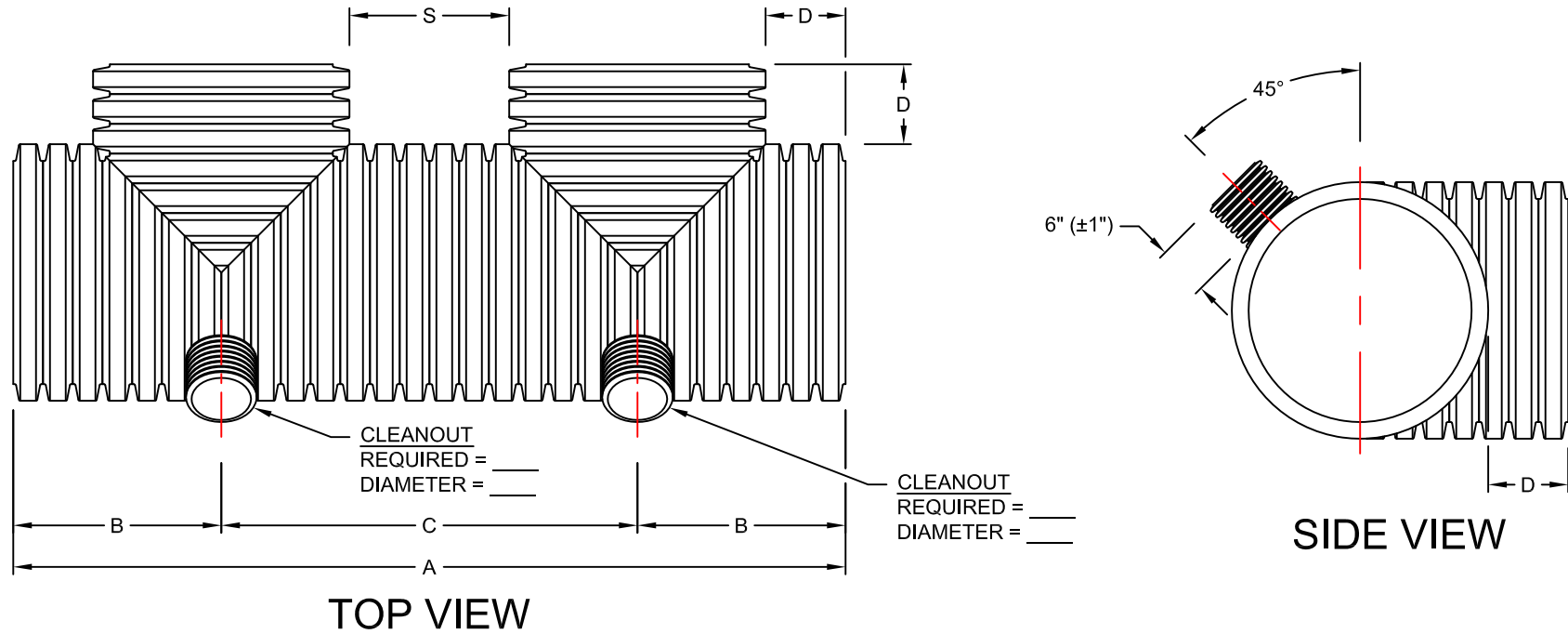

PIPE SIZE	PART #	A	B	C	D	S
12"	XX	47.25"	11.75"	23.50"	4.50"	9.00"
15"	XX	62.00"	15.50"	31.00"	6.75"	13.50"
18"	XX	71.00"	17.75"	35.50"	7.00"	14.00"
24"	XX	94.50"	23.50"	47.25"	9.75"	19.25"
30"	XX	112.00"	28.00"	56.00"	10.75"	21.50"
36"	XX	128.00"	32.00"	64.00"	11.50"	23.00"
42"	XX	149.25"	37.25"	74.75"	13.50"	27.25"
48"	XX	149.25"	37.25"	74.75"	10.00"	20.25"
60"	XX	180.00"	45.00"	90.00"	11.75"	23.25"

NOTE: ALL FITTING DIMENSIONS ARE FOR REFERENCE ONLY.

File Name:		<b>LANE ENTERPRISES, INC.</b>  DOUBLE TEE WITH CLEANOUT
Page Number:	1 OF 1	
Date Drawn:	10-9-15	
Drawn By:	JDS	



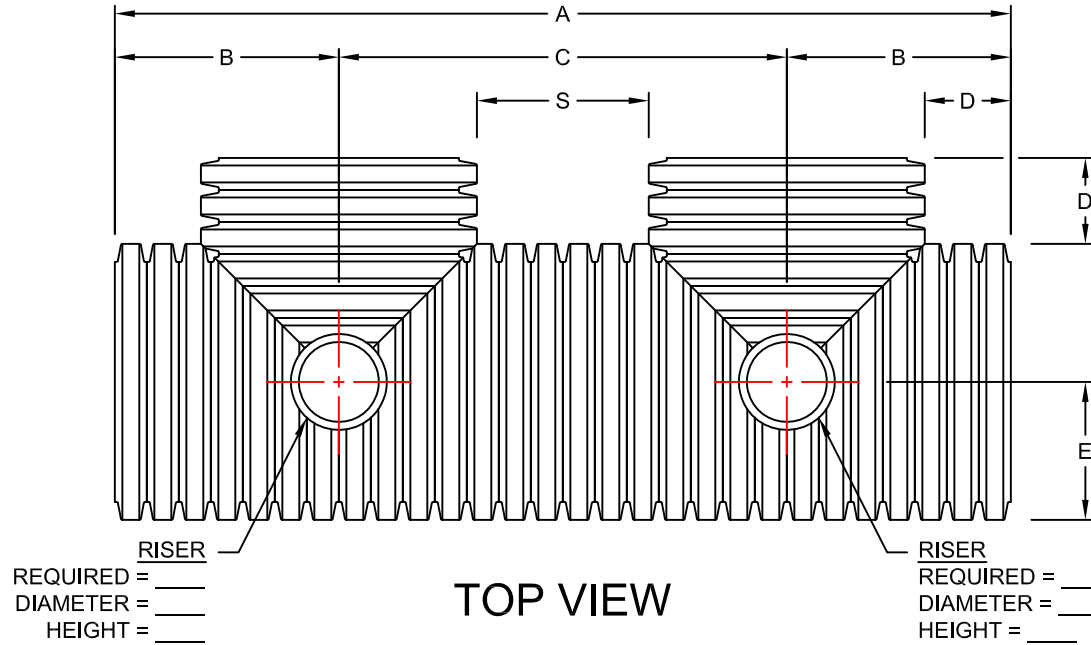

PIPE SIZE	PART #	A	B	C	D	E	S
12"	XX	47.25"	11.75"	23.50"	4.50"	7.25"	9.00"
15"	XX	62.00"	15.50"	31.00"	6.75"	8.75"	13.50"
18"	XX	71.00"	17.75"	35.50"	7.00"	10.75"	14.00"
24"	XX	94.50"	23.50"	47.25"	9.75"	14.00"	19.25"
30"	XX	112.00"	28.00"	56.00"	10.75"	17.25"	21.50"
36"	XX	128.00"	32.00"	64.00"	11.50"	20.50"	23.00"
42"	XX	149.25"	37.25"	74.75"	13.50"	23.75"	27.25"
48"	XX	149.25"	37.25"	74.75"	10.00"	27.25"	20.25"
60"	XX	180.00"	45.00"	90.00"	11.75"	33.25"	23.25"

NOTE: ALL FITTING DIMENSIONS ARE FOR REFERENCE ONLY.

File Name:		<b>LANE ENTERPRISES, INC.</b>	
Page Number:	1 OF 1	<b>DOUBLE TEE WITH RISER</b>	
Date Drawn:	10-9-15		
Drawn By:	JDS		

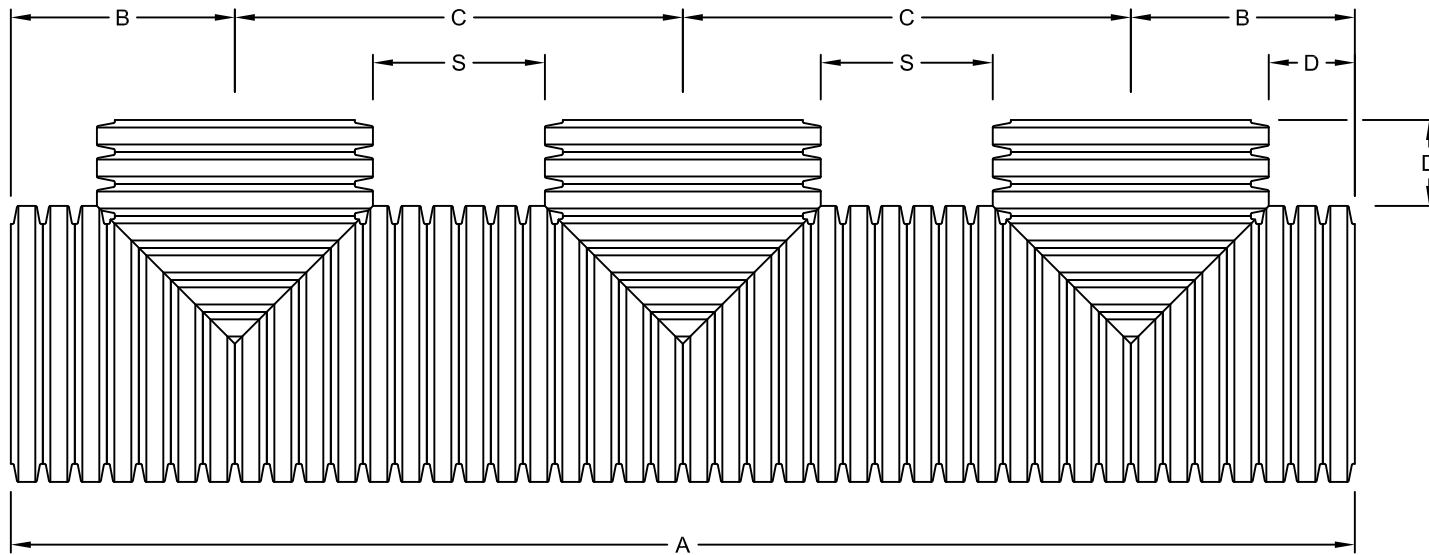

TOP VIEW

PIPE SIZE	PART #	A	B	C	D	S
12"	<a href="#">HDFT12TX3/S</a>	70.75"	11.75"	23.50"	4.50"	9.00"
15"	<a href="#">HDFT15TX3/S</a>	93.00"	15.50"	31.00"	6.75"	13.50"
18"	<a href="#">HDFT18TX3/S</a>	106.75"	17.75"	35.50"	7.00"	14.00"
24"	<a href="#">HDFT24TX3/S</a>	141.75"	23.50"	47.25"	9.75"	19.25"
30"	<a href="#">HDFT30TX3/S</a>	168.00"	28.00"	56.00"	10.75"	21.50"
36"	<a href="#">HDFT36TX3/S</a>	192.00"	32.00"	64.00"	11.50"	23.00"
42"	<a href="#">HDFT42TX3/S</a>	224.00"	37.25"	74.75"	13.50"	27.25"
48"	<a href="#">HDFT48TX3/S</a>	224.00"	37.25"	74.75"	10.00"	20.25"

NOTE: ALL FITTING DIMENSIONS ARE FOR REFERENCE ONLY.

File Name:	P1150	<b>LANE ENTERPRISES, INC.</b>  TRIPLE TEE
Page Number:	1 OF 1	
Date Drawn:	5-9-09	
Drawn By:	JCH	



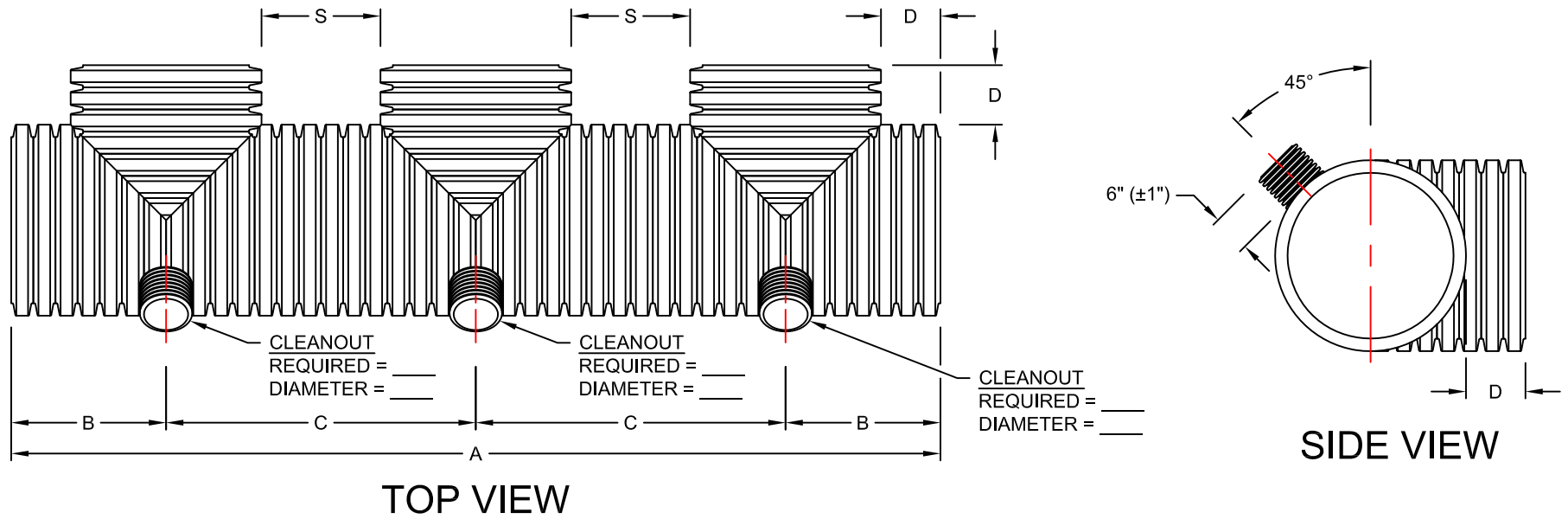

PIPE SIZE	PART #	A	B	C	D	S
12"	XX	70.75"	11.75"	23.50"	4.50"	9.00"
15"	XX	93.00"	15.50"	31.00"	6.75"	13.50"
18"	XX	106.75"	17.75"	35.50"	7.00"	14.00"
24"	XX	141.75"	23.50"	47.25"	9.75"	19.25"
30"	XX	168.00"	28.00"	56.00"	10.75"	21.50"
36"	XX	192.00"	32.00"	64.00"	11.50"	23.00"
42"	XX	224.00"	37.25"	74.75"	13.50"	27.25"
48"	XX	224.00"	37.25"	74.75"	10.00"	20.25"

NOTE: ALL FITTING DIMENSIONS ARE FOR REFERENCE ONLY.

File Name:		<b>LANE ENTERPRISES, INC.</b>  TRIPLE TEE WITH CLEANOUT
Page Number:	1 OF 1	
Date Drawn:	5-31-12	
Drawn By:	JDS	



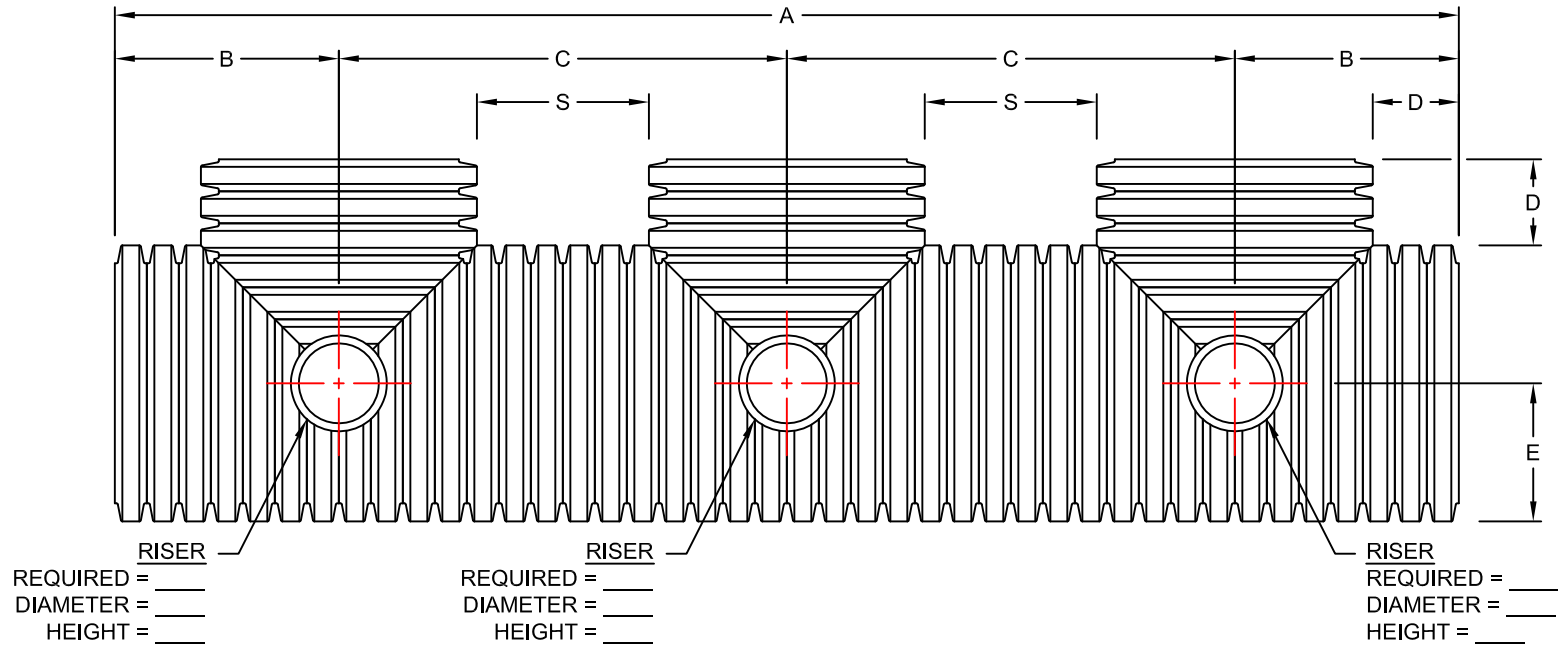

TOP VIEW

PIPE SIZE	PART #	A	B	C	D	E	S
12"	XX	70.75"	11.75"	23.50"	4.50"	7.25"	9.00"
15"	XX	93.00"	15.50"	31.00"	6.75"	8.75"	13.50"
18"	XX	106.75"	17.75"	35.50"	7.00"	10.75"	14.00"
24"	XX	141.75"	23.50"	47.25"	9.75"	14.00"	19.25"
30"	XX	168.00"	28.00"	56.00"	10.75"	17.25"	21.50"
36"	XX	192.00"	32.00"	64.00"	11.50"	20.50"	23.00"
42"	XX	224.00"	37.25"	74.75"	13.50"	23.75"	27.25"
48"	XX	224.00"	37.25"	74.75"	10.00"	27.25"	20.25"

NOTE: ALL FITTING DIMENSIONS ARE FOR REFERENCE ONLY.

File Name:		<b>LANE ENTERPRISES, INC.</b>  TRIPLE TEE WITH RISER
Page Number:	1 OF 1	
Date Drawn:	4-25-12	
Drawn By:	JDS	



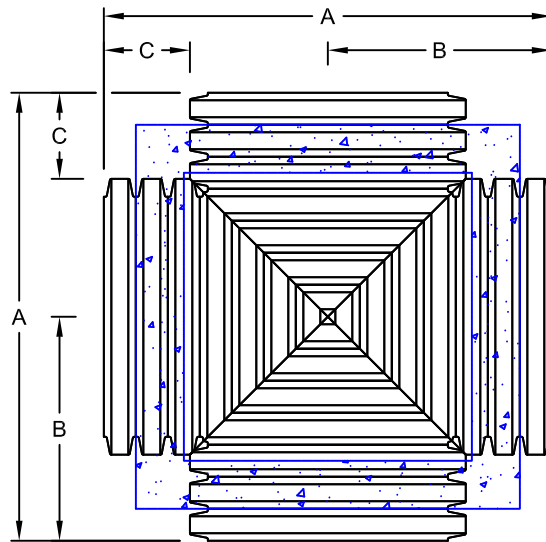

TOP VIEW

PIPE SIZE	PART #	A	B	C
4"	HDFT04CT/S	7.75"	4.00"	1.50"
6"	HDFT06CT/S	12.50"	6.25"	2.75"
8"	HDFT08CT/S	15.50"	7.75"	3.00"
10"	HDFT10CT/S	18.50"	9.25"	3.25"
12"	HDFT12CT/S	23.50"	11.75"	4.50"
15"	HDFT15CT/S	31.00"	15.50"	6.75"
18"	HDFT18CT/S	35.50"	17.75"	7.00"
24"	HDFT24CT/S	47.25"	23.50"	9.75"
* 30"	HDFT30CT/S	56.00"	28.00"	10.75"
* 36"	HDFT36CT/S	64.00"	32.00"	11.50"
* 42"	HDFT42CT/S	74.75"	37.25"	13.50"
* 48"	HDFT48CT/S	74.75"	37.25"	10.00"

\* Requires concrete encasement to at least 6" above fitting

NOTE: ALL FITTING DIMENSIONS ARE FOR REFERENCE ONLY.

File Name:	P1200	<b>LANE ENTERPRISES, INC.</b>  CROSS TEE	
Page Number:	1 OF 1		
Date Drawn:	10-9-15		
Drawn By:	JCH		

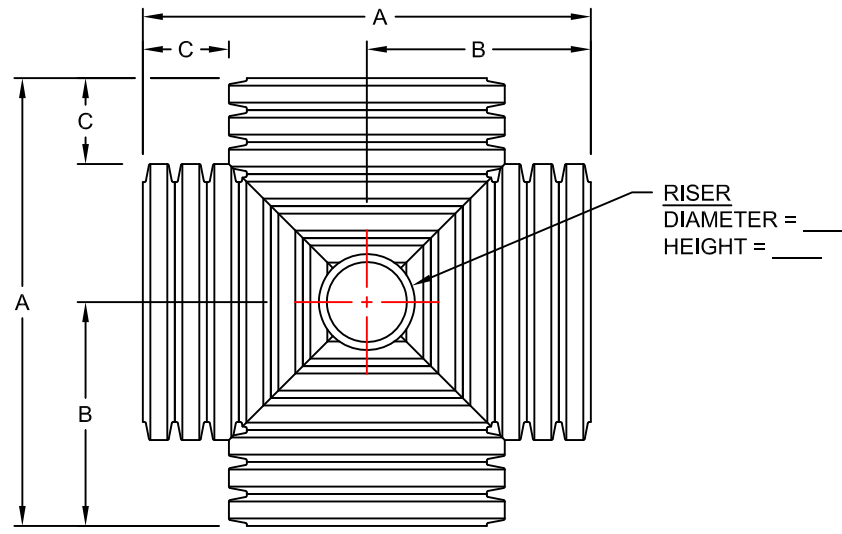

TOP VIEW

PIPE SIZE	PART #	A	B	C
6"	XX	12.50"	6.25"	2.75"
8"	XX	15.50"	7.75"	3.00"
10"	XX	18.50"	9.25"	3.25"
12"	XX	23.50"	11.75"	4.50"
15"	XX	31.00"	15.50"	6.75"
18"	XX	35.50"	17.75"	7.00"
24"	XX	47.25"	23.50"	9.75"
* 30"	XX	56.00"	28.00"	10.75"
* 36"	XX	64.00"	32.00"	11.50"
* 42"	XX	74.75"	37.25"	13.50"
* 48"	XX	74.75"	37.25"	10.00"

\* Requires concrete encasement to at least 6" above fitting

NOTE: ALL FITTING DIMENSIONS ARE FOR REFERENCE ONLY.

File Name:	XX	<b>LANE ENTERPRISES, INC.</b>  <b>CROSS TEE WITH RISER</b>
Page Number:	1 OF 1	
Date Drawn:	10-9-15	
Drawn By:	JDS	



8" REDUCER TEE					
PART #	A	B	C	D	E
HDFT08X04RT/S	8.00"	4.00"	9.75"	4.75"	2.50"

10" REDUCER TEE					
PART #	A	B	C	D	E
HDFT10X04RT/S	10.00"	4.00"	12.25"	6.25"	2.50"
HDFT10X06RT/S	10.00"	6.00"	15.50"	7.75"	3.00"

12" REDUCER TEE					
PART #	A	B	C	D	E
HDFT12X04RT/S	12.00"	4.00"	15.75"	7.75"	2.50"
HDFT12X06RT/S	12.00"	6.00"	15.75"	7.75"	3.00"
HDFT12X08RT/S	12.00"	8.00"	19.75"	9.75"	4.00"
HDFT12X10RT/S	12.00"	10.00"	23.50"	11.75"	4.50"

15" REDUCER TEE					
PART #	A	B	C	D	E
HDFT15X04RT/S	15.00"	4.00"	15.50"	7.75"	2.50"
HDFT15X06RT/S	15.00"	6.00"	20.75"	10.25"	3.00"
HDFT15X08RT/S	15.00"	8.00"	20.75"	10.25"	4.00"
HDFT15X10RT/S	15.00"	10.00"	25.75"	13.00"	4.50"
HDFT15X12RT/S	15.00"	12.00"	25.75"	13.00"	6.00"

18" REDUCER TEE					
PART #	A	B	C	D	E
HDFT18X04RT/S	18.00"	4.00"	17.75"	9.00"	2.50"
HDFT18X06RT/S	18.00"	6.00"	23.75"	11.75"	3.00"
HDFT18X08RT/S	18.00"	8.00"	23.75"	11.75"	4.00"
HDFT18X10RT/S	18.00"	10.00"	23.75"	11.75"	4.50"
HDFT18X12RT/S	18.00"	12.00"	29.75"	14.75"	6.00"
HDFT18X15RT/S	18.00"	15.00"	29.75"	14.75"	7.75"

24" REDUCER TEE					
PART #	A	B	C	D	E
HDFT24X04RT/S	24.00"	4.00"	23.50"	11.75"	2.50"
HDFT24X06RT/S	24.00"	6.00"	23.50"	11.75"	3.00"
HDFT24X08RT/S	24.00"	8.00"	31.50"	15.75"	4.00"
HDFT24X10RT/S	24.00"	10.00"	31.50"	15.75"	4.50"
HDFT24X12RT/S	24.00"	12.00"	31.50"	15.75"	6.00"
HDFT24X15RT/S	24.00"	15.00"	39.25"	19.75"	7.75"
HDFT24X18RT/S	24.00"	18.00"	39.25"	19.75"	9.00"

30" REDUCER TEE					
PART #	A	B	C	D	E
HDFT30X04RT/S	30.00"	4.00"	24.00"	12.00"	2.50"
HDFT30X06RT/S	30.00"	6.00"	24.00"	12.00"	3.00"
HDFT30X08RT/S	30.00"	8.00"	32.00"	16.00"	4.00"
HDFT30X10RT/S	30.00"	10.00"	32.00"	16.00"	4.50"
HDFT30X12RT/S	30.00"	12.00"	32.00"	16.00"	6.00"
HDFT30X15RT/S	30.00"	15.00"	40.00"	20.00"	7.75"
HDFT30X18RT/S	30.00"	18.00"	40.00"	20.00"	9.00"
HDFT30X24RT/S	30.00"	24.00"	48.00"	24.00"	11.75"

36" REDUCER TEE					
PART #	A	B	C	D	E
HDFT36X04RT/S	36.00"	4.00"	24.00"	12.00"	2.50"
HDFT36X06RT/S	36.00"	6.00"	24.00"	12.00"	3.00"
HDFT36X08RT/S	36.00"	8.00"	32.00"	16.00"	4.00"
HDFT36X10RT/S	36.00"	10.00"	32.00"	16.00"	4.50"
HDFT36X12RT/S	36.00"	12.00"	32.00"	16.00"	6.00"
HDFT36X15RT/S	36.00"	15.00"	40.00"	20.00"	7.75"
HDFT36X18RT/S	36.00"	18.00"	40.00"	20.00"	9.00"
HDFT36X24RT/S	36.00"	24.00"	48.00"	24.00"	11.75"
HDFT36X30RT/S	36.00"	30.00"	48.00"	24.00"	12.00"

42" REDUCER TEE					
PART #	A	B	C	D	E
HDFT42X04RT/S	42.00"	4.00"	32.00"	16.00"	2.50"
HDFT42X06RT/S	42.00"	6.00"	32.00"	16.00"	3.00"
HDFT42X08RT/S	42.00"	8.00"	32.00"	16.00"	4.00"
HDFT42X10RT/S	42.00"	10.00"	42.75"	21.25"	4.50"
HDFT42X12RT/S	42.00"	12.00"	42.75"	21.25"	6.00"
HDFT42X15RT/S	42.00"	15.00"	42.75"	21.25"	7.75"
HDFT42X18RT/S	42.00"	18.00"	42.75"	21.25"	9.00"
HDFT42X24RT/S	42.00"	24.00"	53.25"	26.75"	11.75"
HDFT42X30RT/S	42.00"	30.00"	64.00"	32.00"	12.00"
HDFT42X36RT/S	42.00"	36.00"	64.00"	32.00"	12.00"

48" REDUCER TEE					
PART #	A	B	C	D	E
HDFT48X04RT/S	48.00"	4.00"	32.00"	16.00"	2.50"
HDFT48X06RT/S	48.00"	6.00"	32.00"	16.00"	3.00"
HDFT48X08RT/S	48.00"	8.00"	32.00"	16.00"	4.00"
HDFT48X10RT/S	48.00"	10.00"	42.75"	21.25"	4.50"
HDFT48X12RT/S	48.00"	12.00"	42.75"	21.25"	6.00"
HDFT48X15RT/S	48.00"	15.00"	42.75"	21.25"	7.75"
HDFT48X18RT/S	48.00"	18.00"	42.75"	21.25"	9.00"
HDFT48X24RT/S	48.00"	24.00"	53.25"	26.75"	11.75"
HDFT48X30RT/S	48.00"	30.00"	64.00"	32.00"	12.00"
HDFT48X36RT/S	48.00"	36.00"	64.00"	32.00"	12.00"
HDFT48X42RT/S	48.00"	42.00"	74.75"	37.25"	16.00"

60" REDUCER TEE					
PART #	A	B	C	D	E
HDFT60X04RT/S	60.00"	4.00"	36.00"	18.00"	2.50"
HDFT60X06RT/S	60.00"	6.00"	36.00"	18.00"	3.00"
HDFT60X08RT/S	60.00"	8.00"	36.00"	18.00"	4.00"
HDFT60X10RT/S	60.00"	10.00"	48.00"	24.00"	4.50"
HDFT60X12RT/S	60.00"	12.00"	48.00"	24.00"	6.00"
HDFT60X15RT/S	60.00"	15.00"	48.00"	24.00"	7.75"
HDFT60X18RT/S	60.00"	18.00"	48.00"	24.00"	9.00"
HDFT60X24RT/S	60.00"	24.00"	60.00"	30.00"	11.75"
HDFT60X30RT/S	60.00"	30.00"	60.00"	30.00"	12.00"
HDFT60X36RT/S	60.00"	36.00"	72.00"	36.00"	12.00"
HDFT60X42RT/S	60.00"	42.00"	72.00"	36.00"	16.00"
HDFT60X48RT/S	60.00"	48.00"	84.00"	42.00"	16.00"

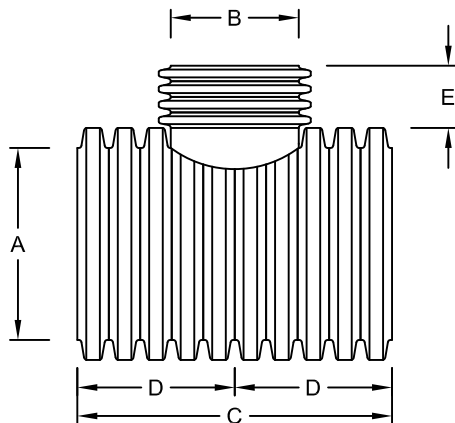

TOP VIEW

NOTE: ALL FITTING DIMENSIONS ARE FOR REFERENCE ONLY.

File Name:	XXX
Page Number:	1 OF 1
Date Drawn:	10/9/15
Drawn By:	JDS

LANE ENTERPRISES, INC.

REDUCER TEE



12" SADDLE TEES			
PART #	A	B	SLEEVED
HDFT12X04ST/S	4.00"	2.50"	NO
HDFT12X06ST/S	6.00"	3.00"	NO

15" SADDLE TEES			
PART #	A	B	SLEEVED
HDFT15X04ST/S	4.00"	2.50"	NO
HDFT15X06ST/S	6.00"	3.00"	NO
HDFT15X08ST/S	8.00"	4.00"	NO
HDFT15X10ST/S	10.00"	4.50"	YES

36" SADDLE TEES			
PART #	A	B	SLEEVED
HDFT36X04ST/S	4.00"	2.50"	NO
HDFT36X06ST/S	6.00"	3.00"	NO
HDFT36X08ST/S	8.00"	4.00"	NO
HDFT36X10ST/S	10.00"	4.50"	NO
HDFT36X12ST/S	12.00"	6.00"	YES
HDFT36X15ST/S	15.00"	7.75"	YES

18" SADDLE TEES			
PART #	A	B	SLEEVED
HDFT18X04ST/S	4.00"	2.50"	NO
HDFT18X06ST/S	6.00"	3.00"	NO
HDFT18X08ST/S	8.00"	4.00"	NO
HDFT18X10ST/S	10.00"	4.50"	YES

42" SADDLE TEES			
PART #	A	B	SLEEVED
HDFT42X04ST/S	4.00"	2.50"	NO
HDFT42X06ST/S	6.00"	3.00"	NO
HDFT42X08ST/S	8.00"	4.00"	NO
HDFT42X10ST/S	10.00"	4.50"	NO
HDFT42X12ST/S	12.00"	6.00"	NO
HDFT42X15ST/S	15.00"	7.75"	NO
HDFT42X18ST/S	18.00"	9.00"	YES

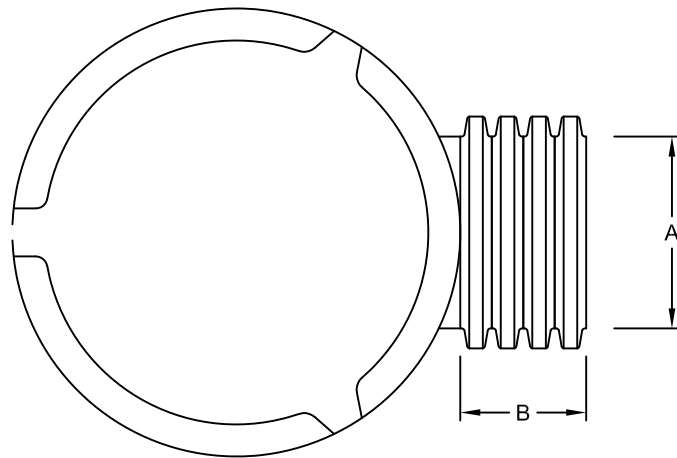

SIDE VIEW

24" SADDLE TEES			
PART #	A	B	SLEEVED
HDFT24X04ST/S	4.00"	2.50"	NO
HDFT24X06ST/S	6.00"	3.00"	NO
HDFT24X08ST/S	8.00"	4.00"	NO
HDFT24X10ST/S	10.00"	4.50"	NO
HDFT24X12ST/S	12.00"	6.00"	YES
HDFT24X15ST/S	15.00"	7.75"	YES

48" SADDLE TEES			
PART #	A	B	SLEEVED
HDFT48X04ST/S	4.00"	2.50"	NO
HDFT48X06ST/S	6.00"	3.00"	NO
HDFT48X08ST/S	8.00"	4.00"	NO
HDFT48X10ST/S	10.00"	4.50"	NO
HDFT48X12ST/S	12.00"	6.00"	NO
HDFT48X15ST/S	15.00"	7.75"	NO
HDFT48X18ST/S	18.00"	9.00"	YES

30" SADDLE TEES			
PART #	A	B	SLEEVED
HDFT30X04ST/S	4.00"	2.50"	NO
HDFT30X06ST/S	6.00"	3.00"	NO
HDFT30X08ST/S	8.00"	4.00"	NO
HDFT30X10ST/S	10.00"	4.50"	NO
HDFT30X12ST/S	12.00"	6.00"	YES
HDFT30X15ST/S	15.00"	7.75"	YES

NOTE: ALL COUPLER DIMENSIONS ARE FOR REFERENCE ONLY.

File Name:	XX	LANE ENTERPRISES, INC.  SADDLE TEE
Page Number:	1 OF 1	
Date Drawn:	4/15/14	
Drawn By:	JDS	



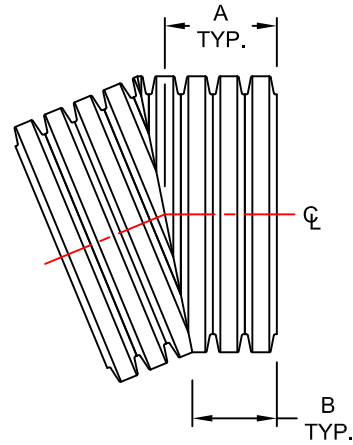

TOP VIEW

PIPE SIZE	PART #	A	B
4"	<a href="#">HDFT04EL22/S</a>	3.00"	2.50"
6"	<a href="#">HDFT06EL22/S</a>	3.50"	2.75"
8"	<a href="#">HDFT08EL22/S</a>	4.25"	3.50"
10"	<a href="#">HDFT10EL22/S</a>	5.50"	4.25"
12"	<a href="#">HDFT12EL22/S</a>	7.00"	5.50"
15"	<a href="#">HDFT15EL22/S</a>	9.00"	7.25"
18"	<a href="#">HDFT18EL22/S</a>	10.25"	8.25"
24"	<a href="#">HDFT24EL22/S</a>	13.75"	11.00"
30"	<a href="#">HDFT30EL22/S</a>	14.00"	10.50"
36"	<a href="#">HDFT36EL22/S</a>	14.00"	10.00"
42"	<a href="#">HDFT42EL22/S</a>	18.75"	14.00"
48"	<a href="#">HDFT48EL22/S</a>	18.75"	13.25"
60"	<a href="#">HDFT48EL22/S</a>	18.00"	11.25"

NOTE: ALL FITTING DIMENSIONS ARE FOR REFERENCE ONLY.

File Name:	P2150	<b>LANE ENTERPRISES, INC.</b>  22.5° ELBOW
Page Number:	1 OF 1	
Date Drawn:	5-10-09	
Drawn By:	JCH	



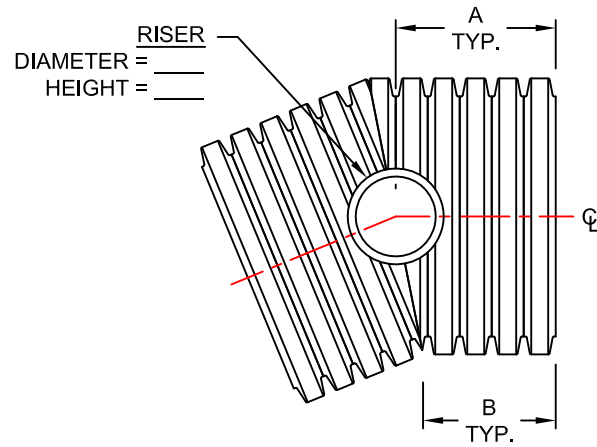

TOP VIEW

PIPE SIZE	PART #	A	B
6"	XX	4.00"	3.25"
8"	XX	5.75"	4.00"
10"	XX	7.75"	6.50"
12"	XX	9.75"	8.50"
15"	XX	13.00"	11.25"
18"	XX	14.75"	12.75"
24"	XX	19.75"	17.00"
30"	XX	20.00"	16.50"
36"	XX	24.00"	20.00"
42"	XX	32.00"	27.25"
48"	XX	32.00"	26.50"
60"	XX	36.00"	29.25"

NOTE: ALL FITTING DIMENSIONS ARE FOR REFERENCE ONLY.

File Name:	XX	<b>LANE ENTERPRISES, INC.</b>  22.5° ELBOW WITH RISER
Page Number:	1 OF 1	
Date Drawn:	10-14-15	
Drawn By:	JDS	



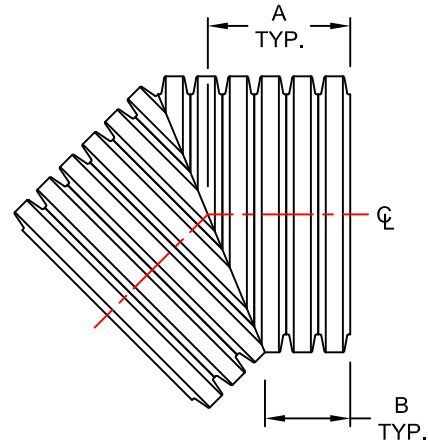

TOP VIEW

PIPE SIZE	PART #	A	B
4"	<a href="#">HDFT04EL45/S</a>	3.50"	2.50"
6"	<a href="#">HDFT06EL45/S</a>	5.00"	3.00"
8"	<a href="#">HDFT08EL45/S</a>	5.25"	3.50"
10"	<a href="#">HDFT10EL45/S</a>	7.00"	4.50"
12"	<a href="#">HDFT12EL45/S</a>	8.75"	5.75"
15"	<a href="#">HDFT15EL45/S</a>	11.50"	8.00"
18"	<a href="#">HDFT18EL45/S</a>	13.25"	9.00"
24"	<a href="#">HDFT24EL45/S</a>	17.75"	12.00"
30"	<a href="#">HDFT30EL45/S</a>	17.75"	10.75"
36"	<a href="#">HDFT36EL45/S</a>	18.00"	9.50"
42"	<a href="#">HDFT42EL45/S</a>	24.00"	14.25"
48"	<a href="#">HDFT48EL45/S</a>	24.00"	12.75"
60"	<a href="#">HDFT60EL45/S</a>	25.25"	12.25"

NOTE: ALL FITTING DIMENSIONS ARE FOR REFERENCE ONLY.

File Name:	P2100	<b>LANE ENTERPRISES, INC.</b>  45° ELBOW
Page Number:	1 OF 1	
Date Drawn:	10-14-15	
Drawn By:	JCH	

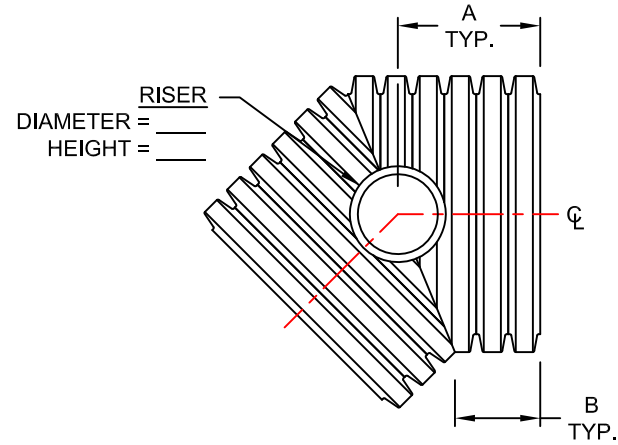

TOP VIEW

PIPE SIZE	PART #	A	B
6"	XX	5.00"	3.50"
8"	XX	5.25"	3.50"
10"	XX	7.00"	4.50"
12"	XX	8.75"	5.75"
15"	XX	11.50"	8.00"
18"	XX	13.25"	9.00"
24"	XX	17.75"	12.00"
30"	XX	17.75"	10.75"
36"	XX	18.00"	9.50"
42"	XX	24.00"	14.25"
48"	XX	24.00"	12.75"
60"	XX	25.25"	12.25"

NOTE: ALL FITTING DIMENSIONS ARE FOR REFERENCE ONLY.

File Name:	XX	LANE ENTERPRISES, INC.  45° ELBOW WITH RISER
Page Number:	1 OF 1	
Date Drawn:	10-14-15	
Drawn By:	JDS	



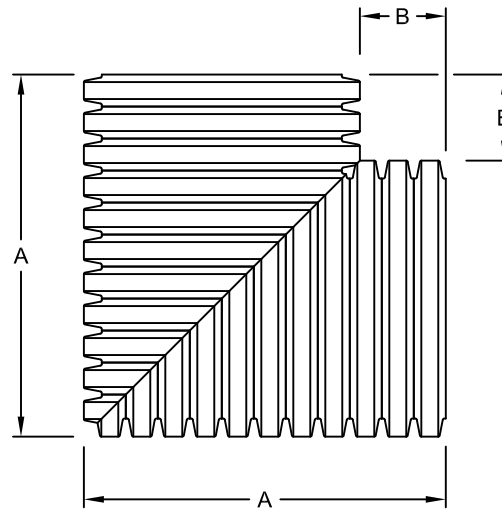

TOP VIEW

PIPE SIZE	PART #	A	B
4"	<a href="#">HDFT04EL90/S</a>	6.25"	1.50"
6"	<a href="#">HDFT06EL90/S</a>	9.75"	2.75"
8"	<a href="#">HDFT08EL90/S</a>	12.50"	3.00"
10"	<a href="#">HDFT10EL90/S</a>	15.25"	3.25"
12"	<a href="#">HDFT12EL90/S</a>	19.00"	4.50"
15"	<a href="#">HDFT15EL90/S</a>	24.25"	6.75"
18"	<a href="#">HDFT18EL90/S</a>	28.50"	7.00"
24"	<a href="#">HDFT24EL90/S</a>	37.75"	9.75"
30"	<a href="#">HDFT30EL90/S</a>	45.25"	10.75"
36"	<a href="#">HDFT36EL90/S</a>	52.50"	11.50"
42"	<a href="#">HDFT42EL90/S</a>	61.00"	13.50"
48"	<a href="#">HDFT48EL90/S</a>	64.50"	10.00"
60"	<a href="#">HDFT60EL90/S</a>	78.25"	11.75"

NOTE: ALL FITTING DIMENSIONS ARE FOR REFERENCE ONLY.

File Name:	P2050	<b>LANE ENTERPRISES, INC.</b>  90° ELBOW
Page Number:	1 OF 1	
Date Drawn:	5-9-09	
Drawn By:	JCH	



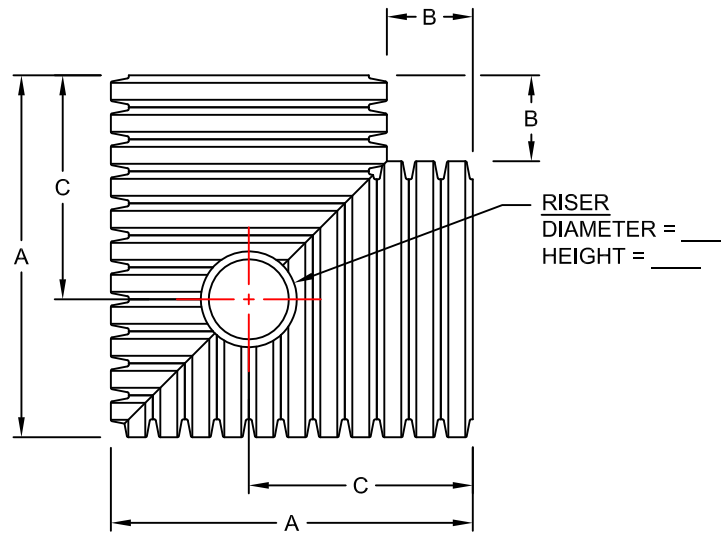

**TOP VIEW**

PIPE SIZE	PART #	A	B	C
6"	XX	9.75"	2.75"	5.50"
8"	XX	12.50"	3.00"	6.75"
10"	XX	15.25"	3.25"	9.25"
12"	XX	19.00"	4.50"	11.75"
15"	XX	24.25"	6.75"	15.50"
18"	XX	28.50"	7.00"	17.75"
24"	XX	37.75"	9.75"	23.50"
30"	XX	45.25"	10.75"	28.00"
36"	XX	52.50"	11.50"	32.00"
42"	XX	61.00"	13.50"	37.25"
48"	XX	64.50"	10.00"	37.25"
60"	XX	78.25"	11.75"	45.00"

NOTE: ALL FITTING DIMENSIONS ARE FOR REFERENCE ONLY.

File Name:	XX	<b>LANE ENTERPRISES, INC.</b>  90° ELBOW WITH RISER
Page Number:	1 OF 1	
Date Drawn:	10-9-15	
Drawn By:	JDS	



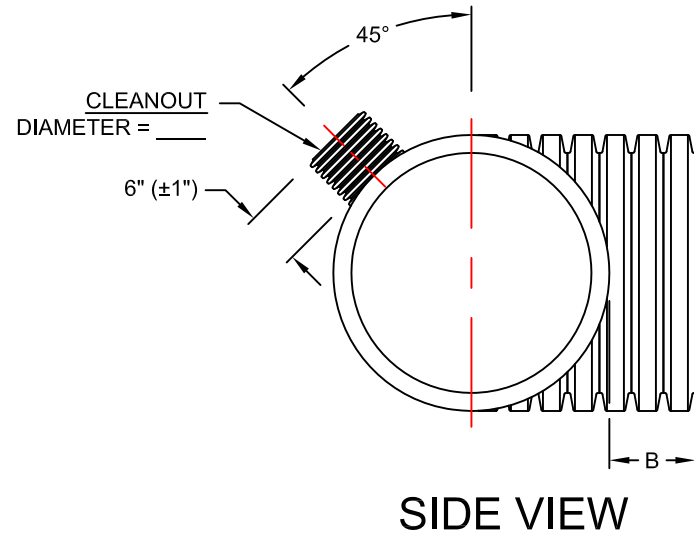
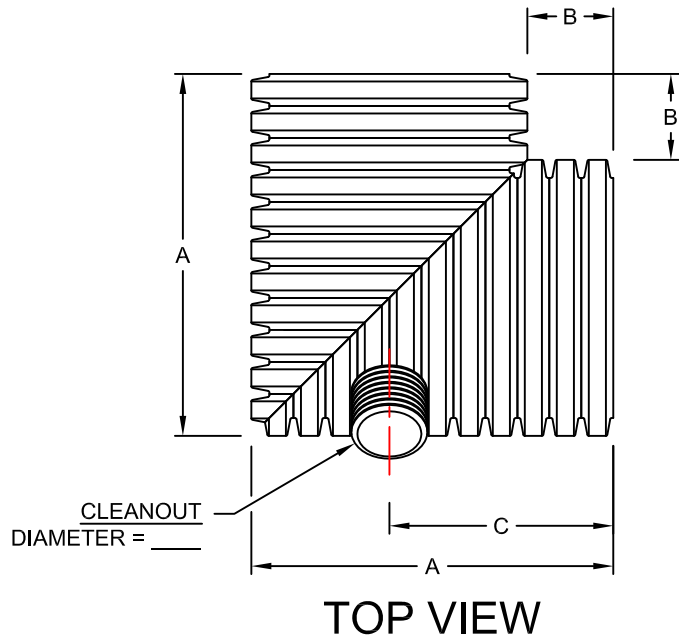

PIPE SIZE	PART #	A	B	C
12"	XX	19.00"	4.50"	11.75"
15"	XX	24.25"	6.75"	15.50"
18"	XX	28.50"	7.00"	17.75"
24"	XX	37.75"	9.75"	23.50"
30"	XX	45.25"	10.75"	28.00"
36"	XX	52.50"	11.50"	32.00"
42"	XX	61.00"	13.50"	37.25"
48"	XX	64.50"	10.00"	37.25"
60"	XX	78.25"	11.75"	45.00"

NOTE: ALL FITTING DIMENSIONS ARE FOR REFERENCE ONLY.

File Name:	XX	<b>LANE ENTERPRISES, INC.</b>  ELBOW WITH CLEANOUT
Page Number:	1 OF 2	
Date Drawn:	10-9-15	
Drawn By:	JDS	



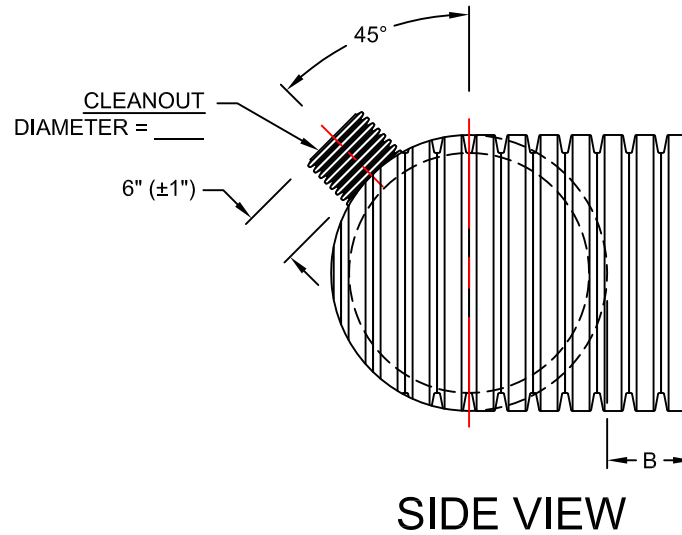
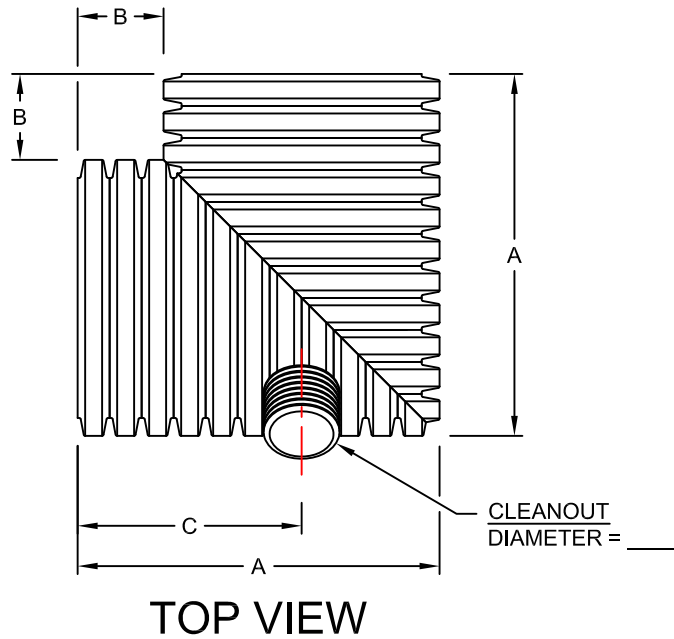

PIPE SIZE	PART #	A	B	C
12"	XX	19.00"	4.50"	11.75"
15"	XX	24.25"	6.75"	15.50"
18"	XX	28.50"	7.00"	17.75"
24"	XX	37.75"	9.75"	23.50"
30"	XX	45.25"	10.75"	28.00"
36"	XX	52.50"	11.50"	32.00"
42"	XX	61.00"	13.50"	37.25"
48"	XX	64.50"	10.00"	37.25"
60"	XX	78.25"	11.75"	45.00"

NOTE: ALL FITTING DIMENSIONS ARE FOR REFERENCE ONLY.

File Name:	XX	<b>LANE ENTERPRISES, INC.</b>  ELBOW WITH CLEANOUT
Page Number:	2 OF 2	
Date Drawn:	10-9-15	
Drawn By:	JDS	



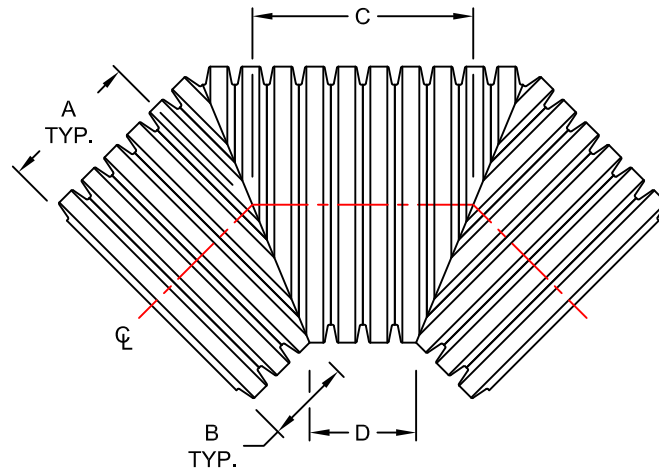

TOP VIEW

PIPE SIZE	PART #	A	B	C	D
4"	<a href="#">HDFT04EL2M90/S</a>	3.25"	2.50"	4.50"	2.25"
6"	<a href="#">HDFT06EL2M90/S</a>	4.50"	3.25"	5.75"	3.25"
8"	<a href="#">HDFT08EL2M90/S</a>	5.25"	3.25"	7.75"	3.75"
10"	<a href="#">HDFT10EL2M90/S</a>	7.50"	5.00"	10.25"	5.50"
12"	<a href="#">HDFT12EL2M90/S</a>	7.75"	4.75"	11.75"	5.75"
15"	<a href="#">HDFT15EL2M90/S</a>	10.50"	7.00"	16.00"	8.75"
18"	<a href="#">HDFT18EL2M90/S</a>	11.75"	7.50"	17.75"	8.75"
24"	<a href="#">HDFT24EL2M90/S</a>	15.75"	10.00"	23.75"	12.25"
30"	<a href="#">HDFT30EL2M90/S</a>	14.75"	8.50"	21.75"	9.00"
36"	<a href="#">HDFT36EL2M90/S</a>	17.50"	9.00"	27.00"	10.00"
42"	<a href="#">HDFT42EL2M90/S</a>	24.75"	16.25"	39.00"	21.50"
48"	<a href="#">HDFT48EL2M90/S</a>	23.50"	12.00"	36.00"	13.50"
60"	<a href="#">HDFT60EL2M90/S</a>	25.25"	11.50"	38.50"	10.75"

NOTE: ALL FITTING DIMENSIONS ARE FOR REFERENCE ONLY.

File Name:	XXX	<b>LANE ENTERPRISES, INC.</b>  90° DOUBLE MITER ELBOW
Page Number:	1 OF 1	
Date Drawn:	10-14-15	
Drawn By:	JDS	



6" REDUCERS				
PART #	A	B	C	D
HDFT06X04RE/S	6.00"	4.00"	3.00"	2.50"

8" REDUCERS				
PART #	A	B	C	D
HDFT08X04RE/S	8.00"	4.00"	3.00"	2.50"
HDFT08X06RE/S	8.00"	6.00"	3.00"	3.00"

10" REDUCERS				
PART #	A	B	C	D
HDFT10X04RE/S	10.00"	4.00"	3.00"	2.50"
HDFT10X06RE/S	10.00"	6.00"	3.00"	3.00"
HDFT10X08RE/S	10.00"	8.00"	3.00"	4.00"

12" REDUCERS				
PART #	A	B	C	D
HDFT12X04RE/S	12.00"	4.00"	4.00"	2.50"
HDFT12X06RE/S	12.00"	6.00"	4.00"	3.00"
HDFT12X08RE/S	12.00"	8.00"	4.00"	4.00"
HDFT12X10RE/S	12.00"	10.00"	4.00"	4.50"

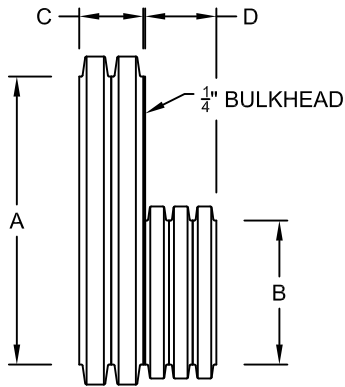

**ELEVATION VIEW**

NOTE: ALL FITTING DIMENSIONS ARE FOR REFERENCE ONLY.

15" REDUCERS				
PART #	A	B	C	D
HDFT15X04RE/S	15.00"	4.00"	5.25"	2.50"
HDFT15X06RE/S	15.00"	6.00"	5.25"	3.00"
HDFT15X08RE/S	15.00"	8.00"	5.25"	4.00"
HDFT15X10RE/S	15.00"	10.00"	5.25"	4.50"
HDFT15X12RE/S	15.00"	12.00"	5.25"	6.00"

18" REDUCERS				
PART #	A	B	C	D
HDFT18X04RE/S	18.00"	4.00"	6.00"	2.50"
HDFT18X06RE/S	18.00"	6.00"	6.00"	3.00"
HDFT18X08RE/S	18.00"	8.00"	6.00"	4.00"
HDFT18X10RE/S	18.00"	10.00"	6.00"	4.50"
HDFT18X12RE/S	18.00"	12.00"	6.00"	6.00"
HDFT18X15RE/S	18.00"	15.00"	6.00"	7.75"

24" REDUCERS				
PART #	A	B	C	D
HDFT24X04RE/S	24.00"	4.00"	7.75"	2.50"
HDFT24X06RE/S	24.00"	6.00"	7.75"	3.00"
HDFT24X08RE/S	24.00"	8.00"	7.75"	4.00"
HDFT24X10RE/S	24.00"	10.00"	7.75"	4.50"
HDFT24X12RE/S	24.00"	12.00"	7.75"	6.00"
HDFT24X15RE/S	24.00"	15.00"	7.75"	7.75"
HDFT24X18RE/S	24.00"	18.00"	7.75"	9.00"

30" REDUCERS				
PART #	A	B	C	D
HDFT30X04RE/S	30.00"	4.00"	8.00"	2.50"
HDFT30X06RE/S	30.00"	6.00"	8.00"	3.00"
HDFT30X08RE/S	30.00"	8.00"	8.00"	4.00"
HDFT30X10RE/S	30.00"	10.00"	8.00"	4.50"
HDFT30X12RE/S	30.00"	12.00"	8.00"	6.00"
HDFT30X15RE/S	30.00"	15.00"	8.00"	7.75"
HDFT30X18RE/S	30.00"	18.00"	8.00"	9.00"
HDFT30X24RE/S	30.00"	24.00"	8.00"	11.75"

36" REDUCERS				
PART #	A	B	C	D
HDFT36X04RE/S	36.00"	4.00"	8.00"	2.50"
HDFT36X06RE/S	36.00"	6.00"	8.00"	3.00"
HDFT36X08RE/S	36.00"	8.00"	8.00"	4.00"
HDFT36X10RE/S	36.00"	10.00"	8.00"	4.50"
HDFT36X12RE/S	36.00"	12.00"	8.00"	6.00"
HDFT36X15RE/S	36.00"	15.00"	8.00"	7.75"
HDFT36X18RE/S	36.00"	18.00"	8.00"	9.00"
HDFT36X24RE/S	36.00"	24.00"	8.00"	11.75"
HDFT36X30RE/S	36.00"	30.00"	8.00"	12.00"

42" REDUCERS				
PART #	A	B	C	D
HDFT42X04RE/S	42.00"	4.00"	10.75"	2.50"
HDFT42X06RE/S	42.00"	6.00"	10.75"	3.00"
HDFT42X08RE/S	42.00"	8.00"	10.75"	4.00"
HDFT42X10RE/S	42.00"	10.00"	10.75"	4.50"
HDFT42X12RE/S	42.00"	12.00"	10.75"	6.00"
HDFT42X15RE/S	42.00"	15.00"	10.75"	7.75"
HDFT42X18RE/S	42.00"	18.00"	10.75"	9.00"
HDFT42X24RE/S	42.00"	24.00"	10.75"	11.75"
HDFT42X30RE/S	42.00"	30.00"	10.75"	12.00"
HDFT42X36RE/S	42.00"	36.00"	10.75"	12.00"

48" REDUCERS				
PART #	A	B	C	D
HDFT48X04RE/S	48.00"	4.00"	10.75"	2.50"
HDFT48X06RE/S	48.00"	6.00"	10.75"	3.00"
HDFT48X08RE/S	48.00"	8.00"	10.75"	4.00"
HDFT48X10RE/S	48.00"	10.00"	10.75"	4.50"
HDFT48X12RE/S	48.00"	12.00"	10.75"	6.00"
HDFT48X15RE/S	48.00"	15.00"	10.75"	7.75"
HDFT48X18RE/S	48.00"	18.00"	10.75"	9.00"
HDFT48X24RE/S	48.00"	24.00"	10.75"	11.75"
HDFT48X30RE/S	48.00"	30.00"	10.75"	12.00"
HDFT48X36RE/S	48.00"	36.00"	10.75"	12.00"
HDFT48X42RE/S	48.00"	42.00"	10.75"	16.00"

60" REDUCERS				
PART #	A	B	C	D
HDFT60X04RE/S	60.00"	4.00"	12.00"	2.50"
HDFT60X06RE/S	60.00"	6.00"	12.00"	3.00"
HDFT60X08RE/S	60.00"	8.00"	12.00"	4.00"
HDFT60X10RE/S	60.00"	10.00"	12.00"	4.50"
HDFT60X12RE/S	60.00"	12.00"	12.00"	6.00"
HDFT60X15RE/S	60.00"	15.00"	12.00"	7.75"
HDFT60X18RE/S	60.00"	18.00"	12.00"	9.00"
HDFT60X24RE/S	60.00"	24.00"	12.00"	11.75"
HDFT60X30RE/S	60.00"	30.00"	12.00"	12.00"
HDFT60X36RE/S	60.00"	36.00"	12.00"	12.00"
HDFT60X42RE/S	60.00"	42.00"	12.00"	16.00"
HDFT60X48RE/S	60.00"	48.00"	12.00"	10.75"

File Name:	XXX
Page Number:	1 OF 1
Date Drawn:	3-28-12
Drawn By:	JDS

**LANE ENTERPRISES, INC.**

**ECCENTRIC REDUCER**



6" REDUCERS				
PART #	A	B	C	D
HDFT06X04R/S	6.00"	4.00"	3.00"	2.50"

8" REDUCERS				
PART #	A	B	C	D
HDFT08X04R/S	8.00"	4.00"	3.00"	2.50"
HDFT08X06R/S	8.00"	6.00"	3.00"	3.00"

10" REDUCERS				
PART #	A	B	C	D
HDFT10X04R/S	10.00"	4.00"	3.00"	2.50"
HDFT10X06R/S	10.00"	6.00"	3.00"	3.00"
HDFT10X08R/S	10.00"	8.00"	3.00"	4.00"

12" REDUCERS				
PART #	A	B	C	D
HDFT12X04R/S	12.00"	4.00"	4.00"	2.50"
HDFT12X06R/S	12.00"	6.00"	4.00"	3.00"
HDFT12X08R/S	12.00"	8.00"	4.00"	4.00"
HDFT12X10R/S	12.00"	10.00"	4.00"	4.50"

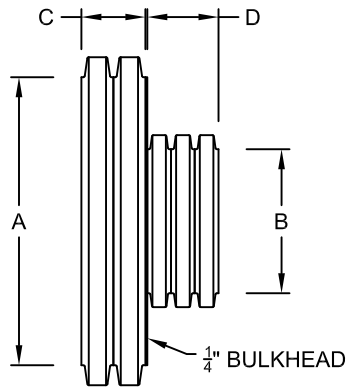

**ELEVATION VIEW**

NOTE: ALL FITTING DIMENSIONS ARE FOR REFERENCE ONLY.

15" REDUCERS				
PART #	A	B	C	D
HDFT15X04R/S	15.00"	4.00"	5.25"	2.50"
HDFT15X06R/S	15.00"	6.00"	5.25"	3.00"
HDFT15X08R/S	15.00"	8.00"	5.25"	4.00"
HDFT15X10R/S	15.00"	10.00"	5.25"	4.50"
HDFT15X12R/S	15.00"	12.00"	5.25"	6.00"

18" REDUCERS				
PART #	A	B	C	D
HDFT18X04R/S	18.00"	4.00"	6.00"	2.50"
HDFT18X06R/S	18.00"	6.00"	6.00"	3.00"
HDFT18X08R/S	18.00"	8.00"	6.00"	4.00"
HDFT18X10R/S	18.00"	10.00"	6.00"	4.50"
HDFT18X12R/S	18.00"	12.00"	6.00"	6.00"
HDFT18X15R/S	18.00"	15.00"	6.00"	7.75"

24" REDUCERS				
PART #	A	B	C	D
HDFT24X04R/S	24.00"	4.00"	7.75"	2.50"
HDFT24X06R/S	24.00"	6.00"	7.75"	3.00"
HDFT24X08R/S	24.00"	8.00"	7.75"	4.00"
HDFT24X10R/S	24.00"	10.00"	7.75"	4.50"
HDFT24X12R/S	24.00"	12.00"	7.75"	6.00"
HDFT24X15R/S	24.00"	15.00"	7.75"	7.75"
HDFT24X18R/S	24.00"	18.00"	7.75"	9.00"

30" REDUCERS				
PART #	A	B	C	D
HDFT30X04R/S	30.00"	4.00"	8.00"	2.50"
HDFT30X06R/S	30.00"	6.00"	8.00"	3.00"
HDFT30X08R/S	30.00"	8.00"	8.00"	4.00"
HDFT30X10R/S	30.00"	10.00"	8.00"	4.50"
HDFT30X12R/S	30.00"	12.00"	8.00"	6.00"
HDFT30X15R/S	30.00"	15.00"	8.00"	7.75"
HDFT30X18R/S	30.00"	18.00"	8.00"	9.00"
HDFT30X24R/S	30.00"	24.00"	8.00"	11.75"

36" REDUCERS				
PART #	A	B	C	D
HDFT36X04R/S	36.00"	4.00"	8.00"	2.50"
HDFT36X06R/S	36.00"	6.00"	8.00"	3.00"
HDFT36X08R/S	36.00"	8.00"	8.00"	4.00"
HDFT36X10R/S	36.00"	10.00"	8.00"	4.50"
HDFT36X12R/S	36.00"	12.00"	8.00"	6.00"
HDFT36X15R/S	36.00"	15.00"	8.00"	7.75"
HDFT36X18R/S	36.00"	18.00"	8.00"	9.00"
HDFT36X24R/S	36.00"	24.00"	8.00"	11.75"
HDFT36X30R/S	36.00"	30.00"	8.00"	12.00"

42" REDUCERS				
PART #	A	B	C	D
HDFT42X04R/S	42.00"	4.00"	10.75"	2.50"
HDFT42X06R/S	42.00"	6.00"	10.75"	3.00"
HDFT42X08R/S	42.00"	8.00"	10.75"	4.00"
HDFT42X10R/S	42.00"	10.00"	10.75"	4.50"
HDFT42X12R/S	42.00"	12.00"	10.75"	6.00"
HDFT42X15R/S	42.00"	15.00"	10.75"	7.75"
HDFT42X18R/S	42.00"	18.00"	10.75"	9.00"
HDFT42X24R/S	42.00"	24.00"	10.75"	11.75"
HDFT42X30R/S	42.00"	30.00"	10.75"	12.00"
HDFT42X36R/S	42.00"	36.00"	10.75"	12.00"

48" REDUCERS				
PART #	A	B	C	D
HDFT48X04R/S	48.00"	4.00"	10.75"	2.50"
HDFT48X06R/S	48.00"	6.00"	10.75"	3.00"
HDFT48X08R/S	48.00"	8.00"	10.75"	4.00"
HDFT48X10R/S	48.00"	10.00"	10.75"	4.50"
HDFT48X12R/S	48.00"	12.00"	10.75"	6.00"
HDFT48X15R/S	48.00"	15.00"	10.75"	7.75"
HDFT48X18R/S	48.00"	18.00"	10.75"	9.00"
HDFT48X24R/S	48.00"	24.00"	10.75"	11.75"
HDFT48X30R/S	48.00"	30.00"	10.75"	12.00"
HDFT48X36R/S	48.00"	36.00"	10.75"	12.00"
HDFT48X42R/S	48.00"	42.00"	10.75"	16.00"

60" REDUCERS				
PART #	A	B	C	D
HDFT60X04R/S	60.00"	4.00"	12.00"	2.50"
HDFT60X06R/S	60.00"	6.00"	12.00"	3.00"
HDFT60X08R/S	60.00"	8.00"	12.00"	4.00"
HDFT60X10R/S	60.00"	10.00"	12.00"	4.50"
HDFT60X12R/S	60.00"	12.00"	12.00"	6.00"
HDFT60X15R/S	60.00"	15.00"	12.00"	7.75"
HDFT60X18R/S	60.00"	18.00"	12.00"	9.00"
HDFT60X24R/S	60.00"	24.00"	12.00"	11.75"
HDFT60X30R/S	60.00"	30.00"	12.00"	12.00"
HDFT60X36R/S	60.00"	36.00"	12.00"	12.00"
HDFT60X42R/S	60.00"	42.00"	12.00"	16.00"
HDFT60X48R/S	60.00"	48.00"	12.00"	10.75"

File Name:	XXX
Page Number:	1 OF 1
Date Drawn:	10-9-15
Drawn By:	JDS

**LANE ENTERPRISES, INC.**

**CONCENTRIC REDUCER**



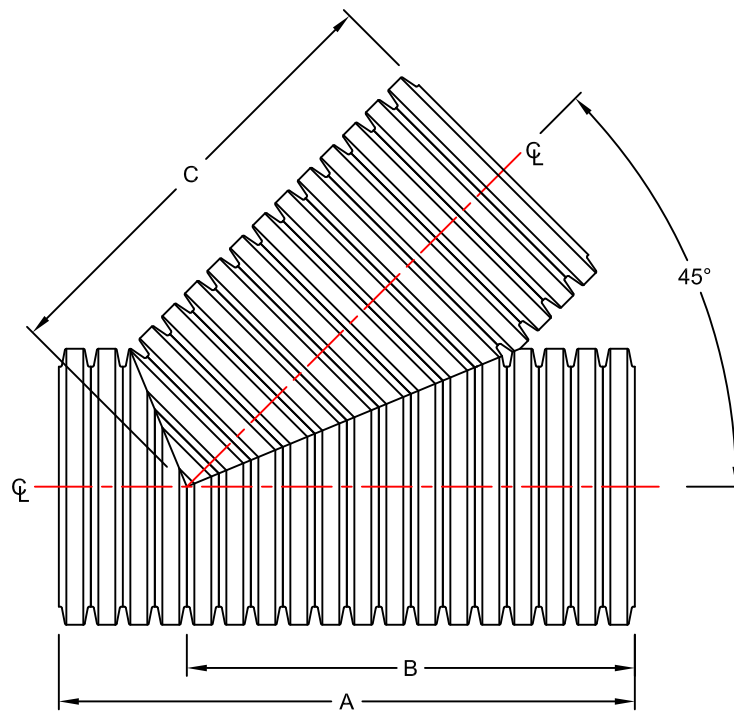

**TOP VIEW**

PIPE SIZE	PART #	A	B	C
4"	<a href="#">HDFT04W/S</a>	14.75"	11.00"	11.00"
6"	<a href="#">HDFT06W/S</a>	14.75"	11.00"	11.00"
8"	<a href="#">HDFT08W/S</a>	19.50"	14.50"	14.50"
10"	<a href="#">HDFT10W/S</a>	24.50"	18.50"	18.50"
12"	<a href="#">HDFT12W/S</a>	31.50"	23.50"	23.50"
15"	<a href="#">HDFT15W/S</a>	41.25"	31.00"	31.00"
18"	<a href="#">HDFT18W/S</a>	47.50"	35.50"	35.50"
24"	<a href="#">HDFT24W/S</a>	63.00"	47.25"	47.25"
30"	<a href="#">HDFT30W/S</a>	72.00"	54.00"	54.00"
36"	<a href="#">HDFT36W/S</a>	84.00"	64.00"	64.00"

NOTE: ALL FITTING DIMENSIONS ARE FOR REFERENCE ONLY.

File Name:	P3050
Page Number:	1 OF 1
Date Drawn:	5-11-09
Drawn By:	JCH

**LANE ENTERPRISES, INC.**

WYE



8" REDUCER WYE					
PART #	A	B	C	D	E
HDFT08X04RW/S	8.00"	4.00"	9.75"	19.50"	6.50"

10" REDUCER WYE					
PART #	A	B	C	D	E
HDFT10X04RW/S	10.00"	4.00"	10.75"	21.50"	6.50"
HDFT10X06RW/S	10.00"	6.00"	10.75"	21.50"	6.25"

12" REDUCER WYE					
PART #	A	B	C	D	E
HDFT12X04RW/S	12.00"	4.00"	11.75"	23.50"	6.50"
HDFT12X06RW/S	12.00"	6.00"	11.75"	23.50"	6.25"
HDFT12X08RW/S	12.00"	8.00"	13.75"	27.50"	6.75"
HDFT12X10RW/S	12.00"	10.00"	15.75"	31.50"	6.25"

15" REDUCER WYE					
PART #	A	B	C	D	E
HDFT15X04RW/S	15.00"	4.00"	13.00"	25.75"	6.50"
HDFT15X06RW/S	15.00"	6.00"	13.00"	25.75"	6.25"
HDFT15X08RW/S	15.00"	8.00"	15.50"	31.00"	6.75"
HDFT15X10RW/S	15.00"	10.00"	15.50"	31.00"	6.25"
HDFT15X12RW/S	15.00"	12.00"	18.00"	36.25"	7.75"

18" REDUCER WYE					
PART #	A	B	C	D	E
HDFT18X04RW/S	18.00"	4.00"	14.75"	29.75"	6.50"
HDFT18X06RW/S	18.00"	6.00"	14.75"	29.75"	6.25"
HDFT18X08RW/S	18.00"	8.00"	14.75"	29.75"	6.75"
HDFT18X10RW/S	18.00"	10.00"	17.75"	35.50"	6.25"
HDFT18X12RW/S	18.00"	12.00"	20.75"	41.50"	7.75"

24" REDUCER WYE					
PART #	A	B	C	D	E
HDFT24X04RW/S	24.00"	4.00"	15.75"	31.50"	6.50"
HDFT24X06RW/S	24.00"	6.00"	15.75"	31.50"	6.25"
HDFT24X08RW/S	24.00"	8.00"	19.75"	39.25"	6.75"
HDFT24X10RW/S	24.00"	10.00"	19.75"	39.25"	6.25"
HDFT24X12RW/S	24.00"	12.00"	23.50"	47.25"	7.75"

30" REDUCER WYE					
PART #	A	B	C	D	E
HDFT30X04RW/S	30.00"	4.00"	16.00"	32.00"	6.50"
HDFT30X06RW/S	30.00"	6.00"	16.00"	32.00"	6.25"
HDFT30X08RW/S	30.00"	8.00"	20.00"	40.00"	6.75"
HDFT30X10RW/S	30.00"	10.00"	20.00"	40.00"	6.25"
HDFT30X12RW/S	30.00"	12.00"	24.00"	48.00"	7.75"

36" REDUCER WYE					
PART #	A	B	C	D	E
HDFT36X04RW/S	36.00"	4.00"	16.00"	32.00"	6.50"
HDFT36X06RW/S	36.00"	6.00"	16.00"	32.00"	6.25"
HDFT36X08RW/S	36.00"	8.00"	20.00"	40.00"	6.75"
HDFT36X10RW/S	36.00"	10.00"	20.00"	40.00"	6.25"
HDFT36X12RW/S	36.00"	12.00"	24.00"	48.00"	7.75"

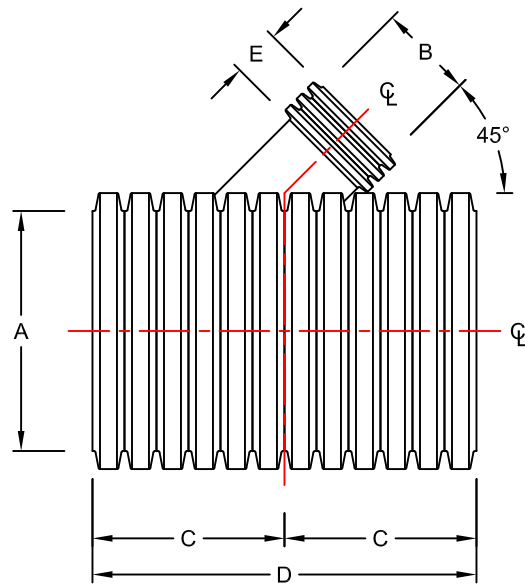

TOP VIEW

NOTE: ALL FITTING DIMENSIONS ARE FOR REFERENCE ONLY.

File Name:	XX
Page Number:	1 OF 2
Date Drawn:	4-18-13
Drawn By:	JDS

LANE ENTERPRISES, INC.

REDUCER WYE



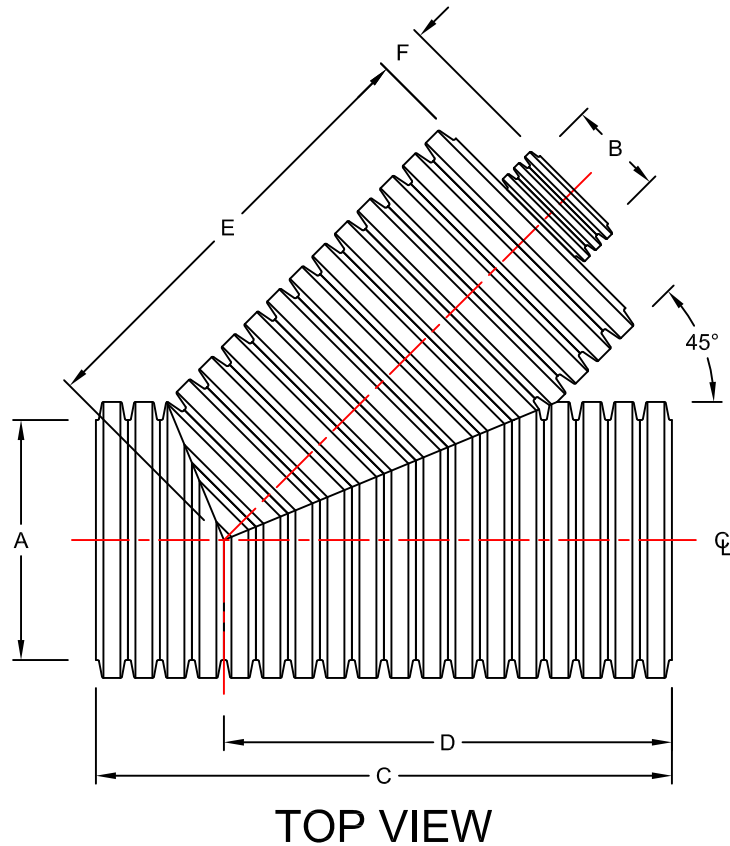

NOTE: ALL FITTING DIMENSIONS ARE FOR REFERENCE ONLY.

**6" REDUCER WYE**

PART #	A	B	C	D	E	F
HDFT06X04RW/S	6.00"	4.00"	14.75"	11.00"	11.00"	2.50"

**8" REDUCER WYE**

PART #	A	B	C	D	E	F
HDFT08X06RW/S	8.00"	6.00"	19.50"	14.50"	14.50"	3.00"

**10" REDUCER WYE**

PART #	A	B	C	D	E	F
HDFT10X08RW/S	10.00"	8.00"	24.50"	18.50"	18.50"	4.00"

**18" REDUCER WYE**

PART #	A	B	C	D	E	F
HDFT18X15RW/S	18.00"	15.00"	47.50"	35.50"	35.50"	7.75"

**24" REDUCER WYE**

PART #	A	B	C	D	E	F
HDFT24X15RW/S	24.00"	15.00"	63.00"	47.25"	47.25"	7.75"
HDFT24X18RW/S	24.00"	18.00"	63.00"	47.25"	47.25"	9.00"

**30" REDUCER WYE**

PART #	A	B	C	D	E	F
HDFT30X15RW/S	30.00"	15.00"	72.00"	54.00"	54.00"	7.75"
HDFT30X18RW/S	30.00"	18.00"	72.00"	54.00"	54.00"	9.00"
HDFT30X24RW/S	30.00"	24.00"	72.00"	54.00"	54.00"	11.75"

**36" REDUCER WYE**

PART #	A	B	C	D	E	F
HDFT36X15RW/S	36.00"	15.00"	84.00"	64.00"	64.00"	7.75"
HDFT36X18RW/S	36.00"	18.00"	84.00"	64.00"	64.00"	9.00"
HDFT36X24RW/S	36.00"	24.00"	84.00"	64.00"	64.00"	11.75"
HDFT36X30RW/S	36.00"	30.00"	84.00"	64.00"	64.00"	12.00"

File Name:	XX
Page Number:	2 OF 2
Date Drawn:	4-18-13
Drawn By:	JDS

LANE ENTERPRISES, INC.

REDUCER WYE



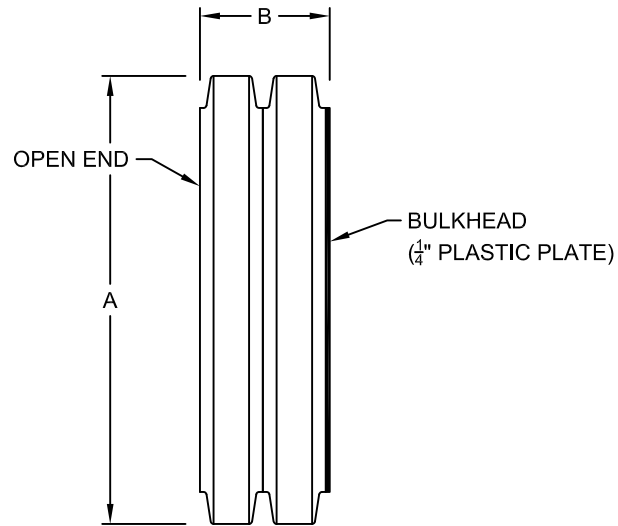

TOP VIEW

PIPE SIZE	PART #	A	B
4"	<a href="#">HDFT04EC/S</a>	4.75"	2.50"
6"	<a href="#">HDFT06EC/S</a>	7.00"	3.25"
8"	<a href="#">HDFT08EC/S</a>	9.50"	3.25"
10"	<a href="#">HDFT10EC/S</a>	12.00"	3.25"
12"	<a href="#">HDFT12EC/S</a>	14.50"	4.25"
15"	<a href="#">HDFT15EC/S</a>	17.50"	5.50"
18"	<a href="#">HDFT18EC/S</a>	21.50"	6.25"
24"	<a href="#">HDFT24EC/S</a>	28.00"	8.00"
30"	<a href="#">HDFT30EC/S</a>	34.50"	8.25"
36"	<a href="#">HDFT36EC/S</a>	41.00"	8.25"
42"	<a href="#">HDFT42EC/S</a>	47.50"	11.00"
48"	<a href="#">HDFT48EC/S</a>	54.50"	11.00"
60"	<a href="#">HDFT60EC/S</a>	66.75"	12.00"

NOTE: ALL FITTING DIMENSIONS ARE FOR REFERENCE ONLY.

File Name:	XXX	LANE ENTERPRISES, INC.  END CAP
Page Number:	1 OF 1	
Date Drawn:	3-28-12	
Drawn By:	JDS	



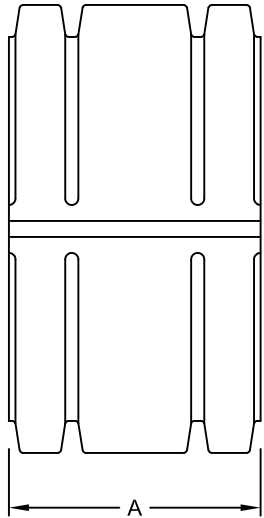

FRONT VIEW

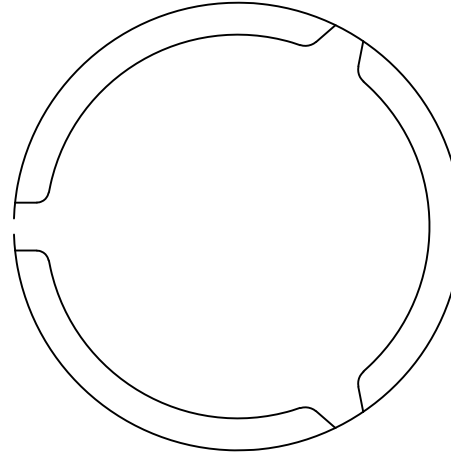

SIDE VIEW



ISOMETRIC VIEW

COUPLER SIZE	PART #	A
8"	<a href="#">HDCP08</a>	6.00"
10"	<a href="#">HDCP10</a>	5.50"
12"	<a href="#">HDCP12</a>	7.50"
15"	<a href="#">HDCP15</a>	11.00"
18"	<a href="#">HDCP18</a>	11.00"
24"	<a href="#">HDCP24</a>	14.50"
30"	<a href="#">HDCP30</a>	16.00"
36"	<a href="#">HDCP36</a>	16.00"

-ALL COUPLER DIMENSIONS ARE FOR REFERENCE ONLY.  
 -8" TO 10" COUPLERS MEET THE PERFORMANCE AND MATERIAL REQUIREMENTS OF AASHTO M252.  
 -12" TO 36" COUPLERS MEET THE PERFORMANCE AND MATERIAL REQUIREMENTS FOR SOIL-TIGHT JOINTS PER AASHTO M294.

File Name:	XX	LANE ENTERPRISES, INC.  8"-36" LANE WRAP AROUND COUPLERS	
Page Number:	1 OF 3		
Date Drawn:	7/29/20		
Drawn By:	JDS		

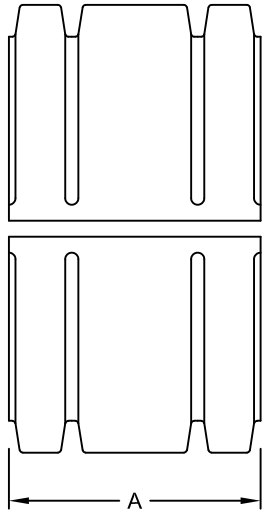

FRONT VIEW

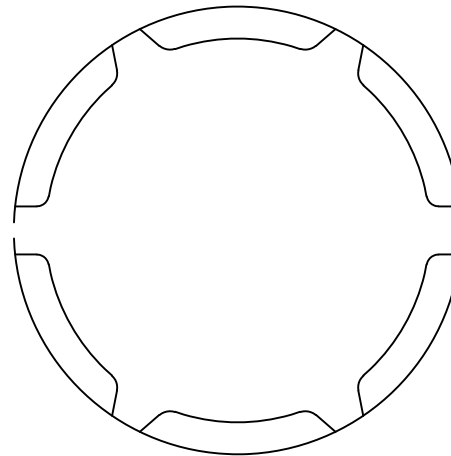

SIDE VIEW



ISOMETRIC VIEW

COUPLER SIZE	PART #	A
42"	<a href="#">HDCP42</a>	21.50"
48"	<a href="#">HDCP48</a>	21.50"

-ALL COUPLER DIMENSIONS ARE FOR REFERENCE ONLY.  
 -COUPLERS MEET THE PERFORMANCE AND MATERIAL REQUIREMENTS FOR SOIL-TIGHT JOINTS PER AASHTO M294.

File Name:	XX	LANE ENTERPRISES, INC.  42"-48" LANE WRAP AROUND COUPLERS	
Page Number:	2 OF 3		
Date Drawn:	7/29/20		
Drawn By:	JDS		

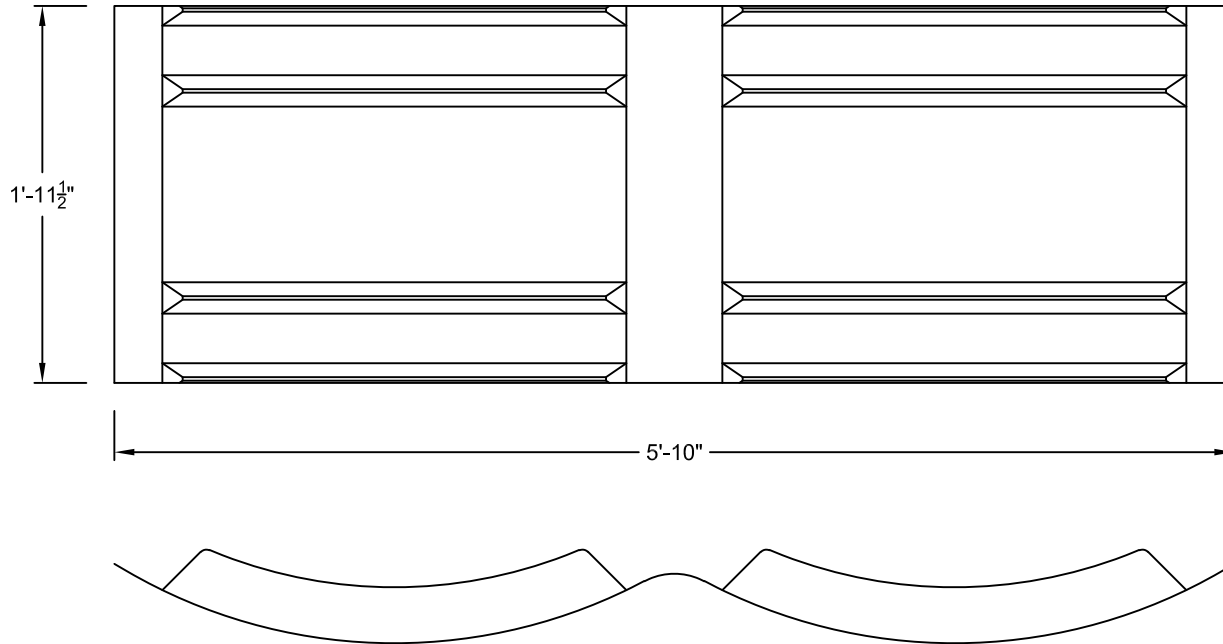

-ALL COUPLER DIMENSIONS ARE FOR REFERENCE ONLY.  
 -COUPLERS MEET THE PERFORMANCE AND MATERIAL REQUIREMENTS FOR SOIL-TIGHT JOINTS PER AASHTO M294.

File Name:	XX	LANE ENTERPRISES, INC.
Page Number:	3 OF 3	
Date Drawn:	7/29/20	
Drawn By:	JDS	
		60" LANE WRAP AROUND COUPLERS



CORRUGATED HDPE SINGLE WIDE SPLIT BAND COUPLER

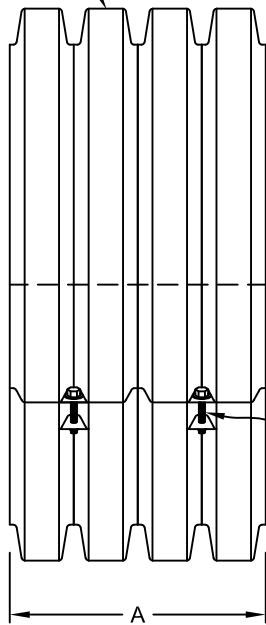

INSTALL TWO BOLTS & NUTS (MINIMUM ON EACH SIDE) THROUGH HOLES IN COUPLER AND TIGHTEN SECURELY AROUND PIPE

CORRUGATED HDPE SINGLE WIDE SPLIT BAND COUPLER

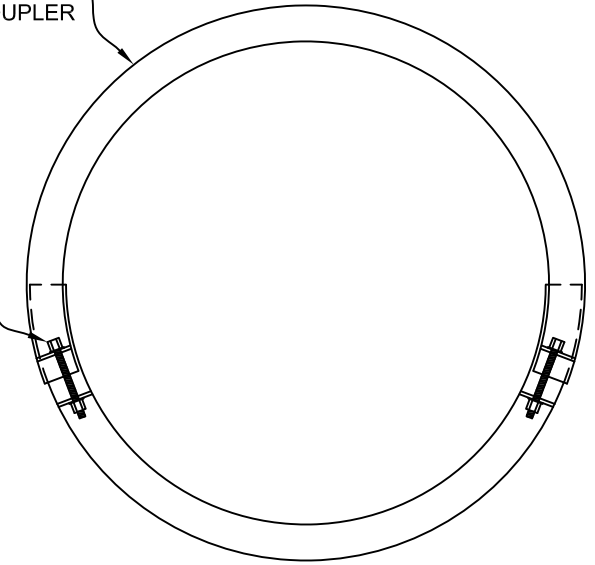

INSTALL TWO BOLTS & NUTS (MINIMUM ON EACH SIDE) THROUGH HOLES IN COUPLER AND TIGHTEN SECURELY AROUND PIPE

PIPE SIZE	PART #	A
42"	<a href="#">HDCP42X2</a>	21.25"
48"	<a href="#">HDCP48X2</a>	21.25"

- ALL FITTING DIMENSIONS ARE FOR REFERENCE ONLY.
- ALL BOLTS SHALL BE  $\frac{5}{16}$ " DIAMETER,  $6\frac{1}{2}$ " LONG, STAINLESS STEEL WITH  $\frac{5}{16}$ " WASHERS.
- COUPLERS MEET THE PERFORMANCE AND MATERIAL REQUIREMENTS FOR SOIL-TIGHT JOINTS PER AASHTO M294.

File Name:	XX
Page Number:	1 OF 1
Date Drawn:	7/29/20
Drawn By:	JDS

**LANE ENTERPRISES, INC.**  
  
 SINGLE WIDE SPLIT COUPLERS  
 42" THROUGH 48"



INSTALL FOUR BOLTS, NUTS AND WASHERS (MINIMUM) THROUGH HOLES IN COUPLER AND TIGHTEN SECURELY AROUND PIPE

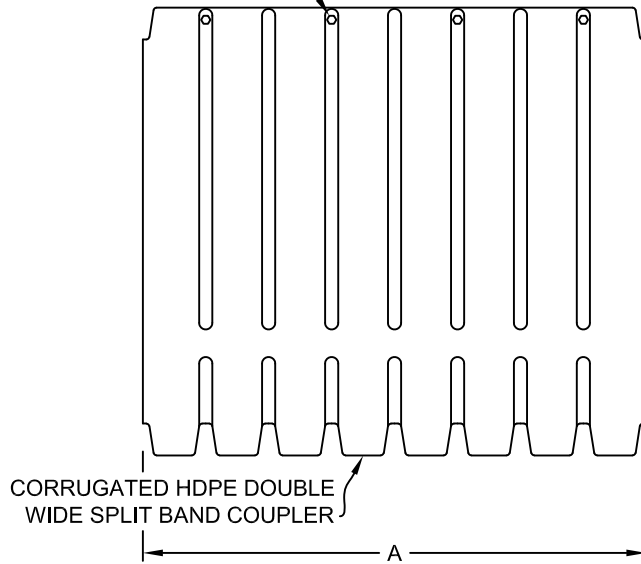

INSTALL FOUR BOLTS & NUTS (MINIMUM) THROUGH HOLES IN COUPLER AND TIGHTEN SECURELY AROUND PIPE

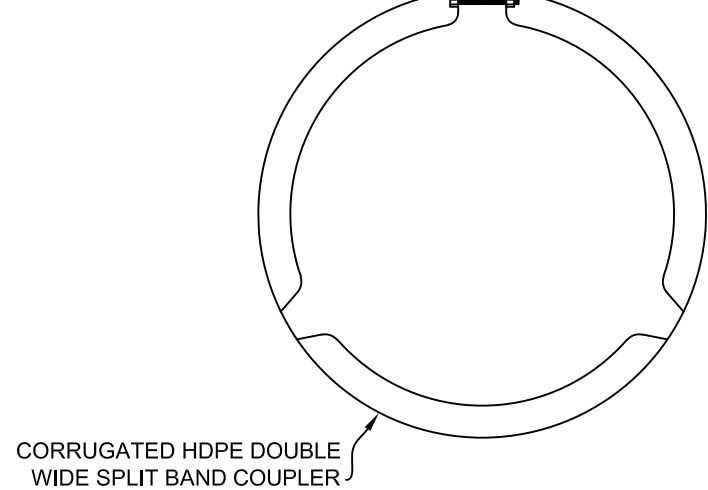

CORRUGATED HDPE DOUBLE WIDE SPLIT BAND COUPLER

CORRUGATED HDPE DOUBLE WIDE SPLIT BAND COUPLER

PIPE SIZE	PART #	A
8"	XX	7.75"
10"	XX	12.25"
12"	XX	15.75"
15"	XX	20.75"
18"	XX	23.50"
24"	XX	31.50"

- ALL FITTING DIMENSIONS ARE FOR REFERENCE ONLY.
- ALL BOLTS SHALL BE 1/4" DIAMETER, 4" LONG, STAINLESS STEEL. NO WASHER REQUIRED.
- 8" TO 10" COUPLERS MEET THE PERFORMANCE AND MATERIAL REQUIREMENTS OF AASHTO M252.
- 12" TO 24" COUPLERS MEET THE PERFORMANCE AND MATERIAL REQUIREMENTS FOR SOIL-TIGHT JOINTS PER AASHTO M294.

File Name:	XX
Page Number:	1 OF 2
Date Drawn:	7/29/20
Drawn By:	JDS

**LANE ENTERPRISES, INC.**  
  
 DOUBLE WIDE SPLIT COUPLERS  
 8" THROUGH 24"



CORRUGATED HDPE DOUBLE WIDE SPLIT BAND COUPLER

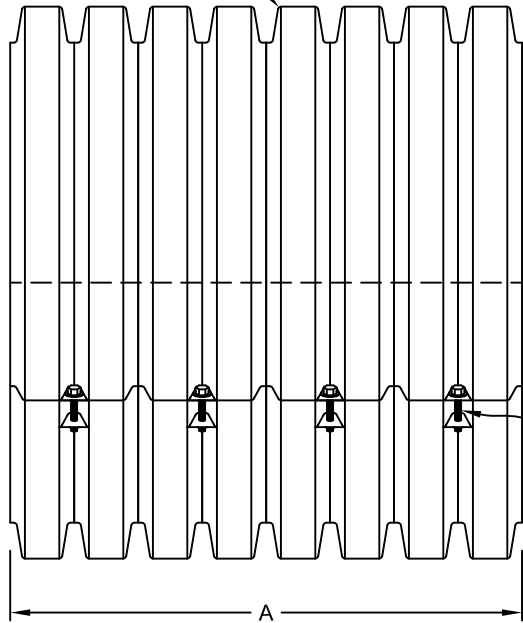

INSTALL FOUR BOLTS & NUTS (MINIMUM ON EACH SIDE) THROUGH HOLES IN COUPLER AND TIGHTEN SECURELY AROUND PIPE

CORRUGATED HDPE DOUBLE WIDE SPLIT BAND COUPLER

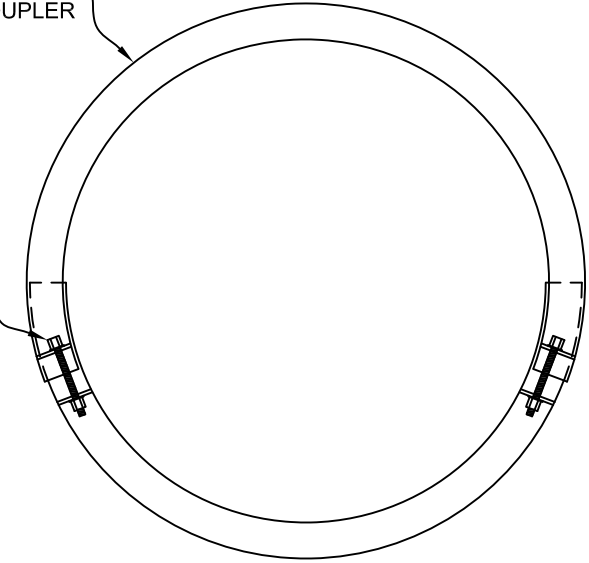

INSTALL FOUR BOLTS & NUTS (MINIMUM ON EACH SIDE) THROUGH HOLES IN COUPLER AND TIGHTEN SECURELY AROUND PIPE

PIPE SIZE	PART #	A
30"	<a href="#">HDCP30X2DW</a>	32.00"
36"	<a href="#">HDCP36X2DW</a>	32.00"
42"	<a href="#">HDCP42X2DW</a>	42.75"
48"	<a href="#">HDCP48X2DW</a>	42.75"

- ALL FITTING DIMENSIONS ARE FOR REFERENCE ONLY.
- ALL BOLTS SHALL BE  $\frac{5}{16}$ " DIAMETER,  $6\frac{1}{2}$ " LONG, STAINLESS STEEL WITH  $\frac{5}{16}$ " WASHERS.
- COUPLERS MEET THE PERFORMANCE AND MATERIAL REQUIREMENTS FOR SOIL-TIGHT JOINTS PER AASHTO M294.

File Name:	XX
Page Number:	2 OF 2
Date Drawn:	7/29/20
Drawn By:	JDS

LANE ENTERPRISES, INC.

DOUBLE WIDE SPLIT COUPLERS  
30" THROUGH 48"



HDPE RISER DETAILS (IF REQUIRED)	
BYPASS RISER DIAMETER	_____"
INLET PIPE INVERT	_____"
BYPASS PIPE INVERT	_____"
CFT RISER HEIGHT	_____"
BYPASS RISER HEIGHT	_____"

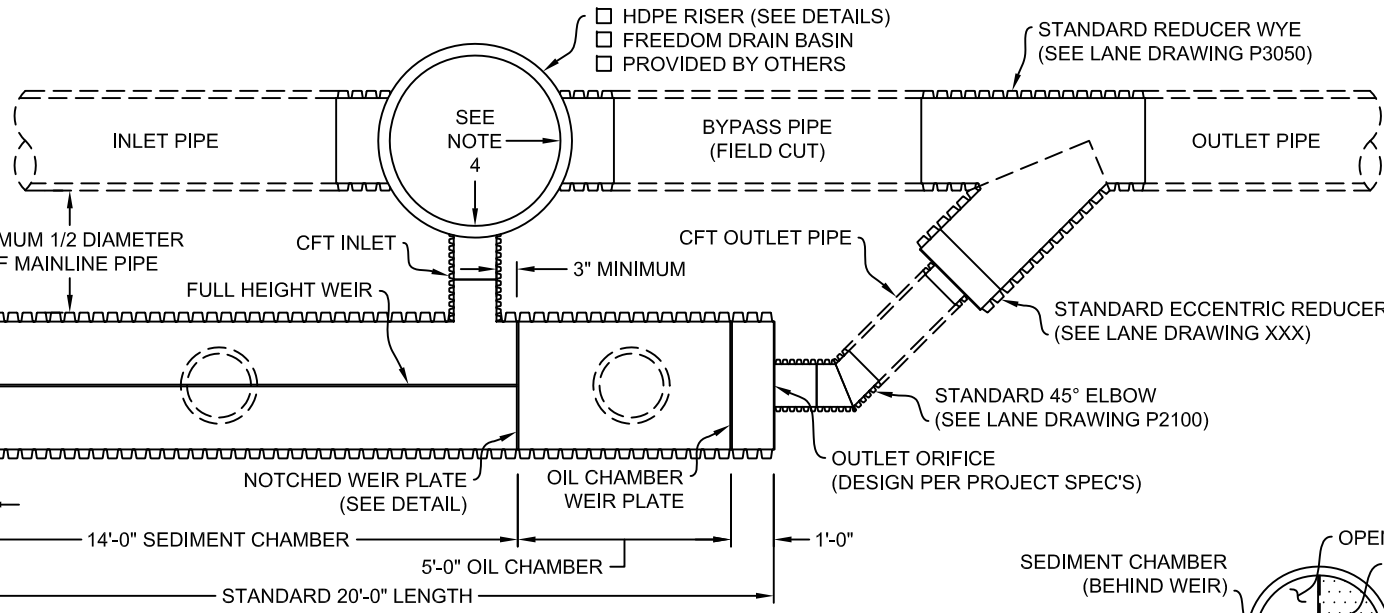

**PLAN SECTION VIEW**

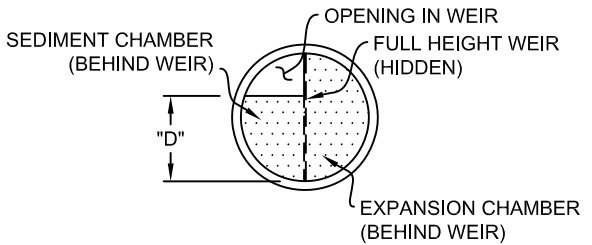

**NOTCHED WEIR PLATE DETAIL**

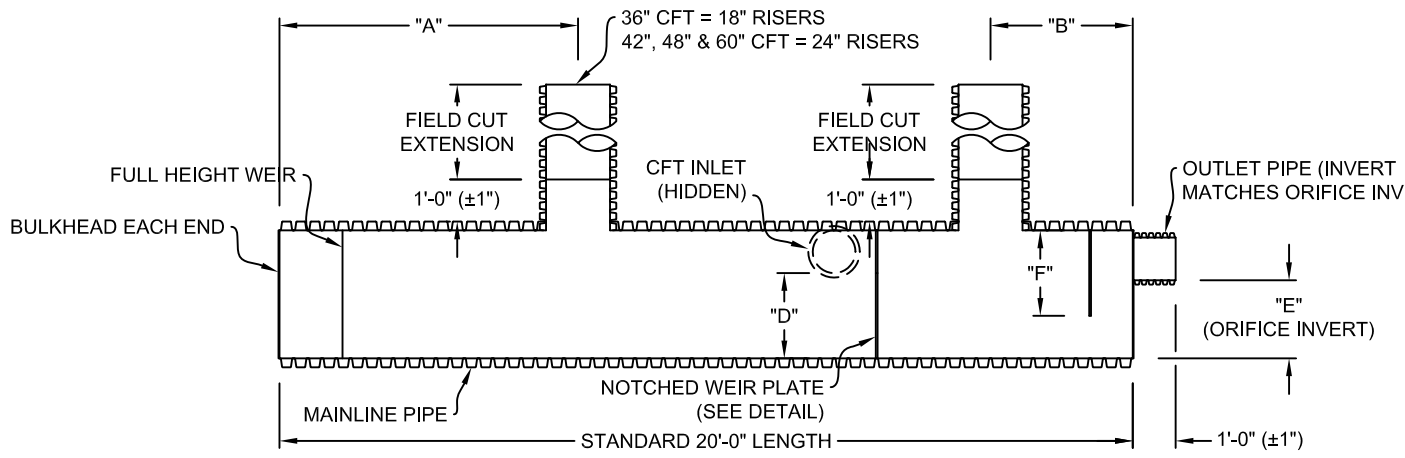

**PROFILE SECTION VIEW**

PROJECT CFT SPECIFICATIONS	
PARTICLE SIEVE SIZE	140 or 200
MAINLINE DIAMETER	_____"
INLET/OUTLET DIAMETER	_____"
BYPASS DIAMETER	_____"
OUTLET ORIFICE DIAMETER	_____"

MAINLINE DIAMETER	MAINLINE LENGTH	INLET & OUTLET	A	B	C	D	E	F
36"	20'-0"	10"	7'-0"	3'-4"	1'-6"	2'-2"	2'-0"	2'-0"
42"			7'-1 1/4"	3'-6 3/4"	1'-9"	2'-8"	2'-6"	2'-6"
48"			7'-1 1/4"	3'-6 3/4"	2'-0"	3'-2"	3'-0"	3'-0"
36"	20'-0"	12"	7'-0"	3'-4"	1'-6"	2'-0"	1'-10"	2'-0"
42"			7'-1 1/4"	3'-6 3/4"	1'-9"	2'-6"	2'-4"	2'-6"
48"			7'-1 1/4"	3'-6 3/4"	2'-0"	3'-0"	2'-10"	3'-0"
60"	20'-0"	15"	7'-1 1/4"	3'-2 3/4"	2'-0"	3'-9"	3'-7"	4'-0"

**GENERAL NOTES:**

- 1.) HDPE Riser (Maximum Height of 8' From Top Of Pipe) Shall Be Backfilled With 1'-0" Minimum Perimeter Manufactured Crushed Aggregate Compacted In 8" Lifts.
- 2.) For Traffic Loading Conditions, Riser(s) Lid & Frame Loads Shall Not Bear On Riser. Install Concrete Collar Around Riser For Lid And Frame Placement (By Others).
- 3.) Invert Elevation At Connection Of CFT Outlet To Bypass Pipe Must Be Lower Than CFT Outlet Orifice.
- 4.) Match Invert of Bypass Pipe And Crown of CFT Inlet Elevations.
- 5.) CFT Backfill Material Shall Be Manufactured - Aggregates Open Graded, Clean Meeting ASTM D2321 Specifications.
- 6.) Top Of Full Height Weir Plate Dividing The Expansion/Sediment Chamber Inside Riser Shall, At A Minimum, Match The Invert Of The Bypass Pipe.

-Lane's Manufacturing Tolerances per AASHTO M294.  
-All Dimensions are nominal. (Unless otherwise noted)

PROJECT NAME:	CUSTOMER:	DRAWN BY:	DATE:
LOCATION:	DESCRIPTION:	JCH/JDS	11/28/12
STANDARD 20' CFT		DRAWING NUMBER:	PAGE:
			1 OF 2



HDPE RISER DETAILS (IF REQUIRED)	
BYPASS RISER DIAMETER	_____"
INLET PIPE INVERT	_____"
BYPASS PIPE INVERT	_____"
CFT RISER HEIGHT	_____"
BYPASS RISER HEIGHT	_____"

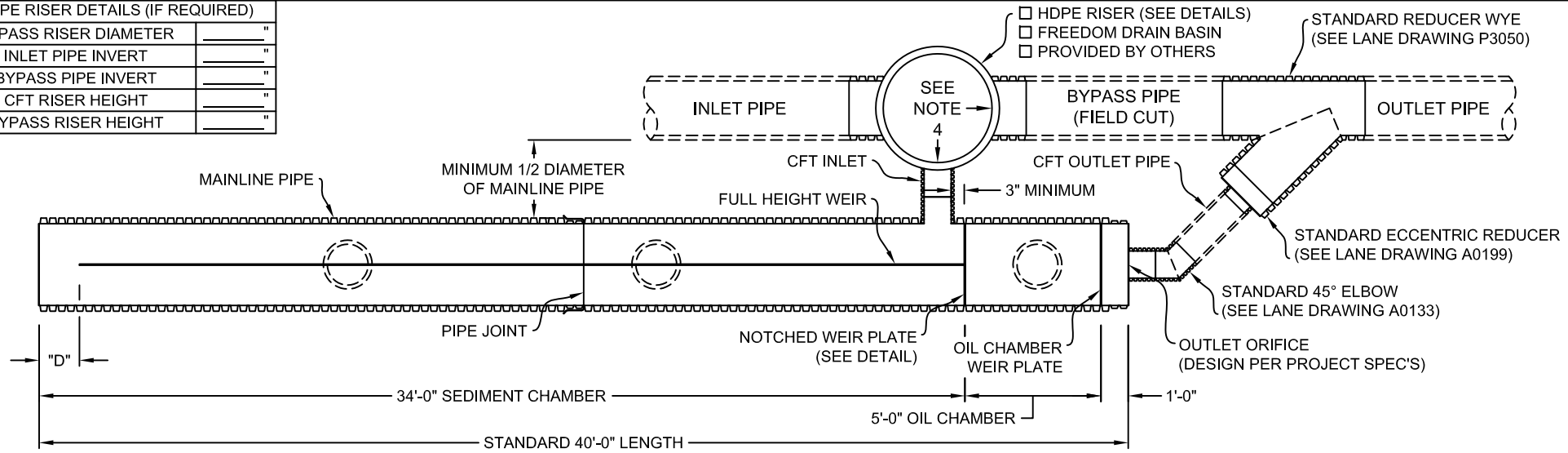

**PLAN SECTION VIEW**

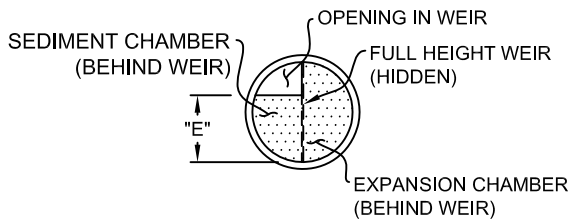

**NOTCHED WEIR PLATE DETAIL**

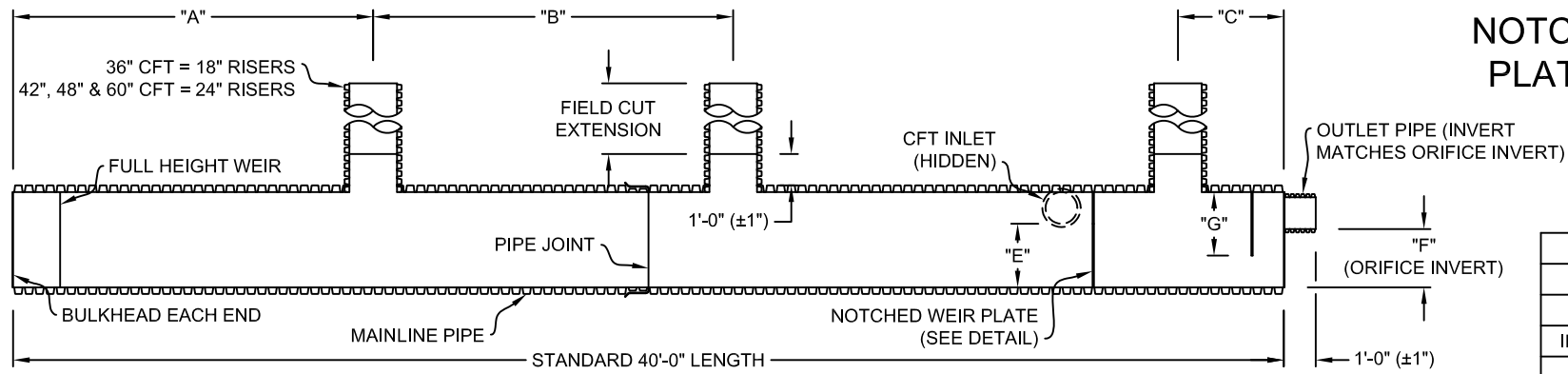

**PROFILE SECTION VIEW**

PROJECT CFT SPECIFICATIONS	
PARTICLE SIEVE SIZE	140 or 200
MAINLINE DIAMETER	_____"
INLET/OUTLET DIAMETER	_____"
BYPASS DIAMETER	_____"
OUTLET ORIFICE DIAMETER	_____"

**GENERAL NOTES:**

- 1.) HDPE Riser (Maximum Height of 8' From Top Of Pipe) Shall Be Backfilled With 1'-0" Minimum Perimeter Manufactured Crushed Aggregate Compacted In 8" Lifts.
- 2.) For Traffic Loading Conditions, Riser(s) Lid & Frame Loads Shall Not Bear On Riser. Install Concrete Collar Around Riser For Lid And Frame Placement (By Others).
- 3.) Invert Elevation At Connection Of CFT Outlet To Bypass Pipe Must Be Lower Than CFT Outlet Orifice.
- 4.) Match Invert of Bypass Pipe And Crown of CFT Inlet Elevations.
- 5.) CFT Backfill Material Shall Be Manufactured - Aggregates Open Graded, Clean Meeting ASTM D2321 Specifications.
- 6.) Top Of Full Height Weir Plate Dividing The Expansion/Sediment Chamber Inside Riser Shall, At A Minimum, Match The Invert Of The Bypass Pipe.

MAINLINE DIAMETER	MAINLINE LENGTH	INLET & OUTLET	A	B	C	D	E	F	G
36"	40'-0"	10"	10'-0"	15'-4"	5'-0"	1'-6"	2'-2"	2'-0"	2'-0"
42"			9'-9 1/4"	15'-6 3/4"	4'-10 3/4"	1'-9"	2'-8"	2'-6"	2'-6"
48"			9'-9 1/4"	15'-6 3/4"	4'-10 3/4"	2'-0"	3'-2"	3'-0"	3'-0"
36"	40'-0"	12"	10'-0"	15'-4"	5'-0"	1'-6"	2'-0"	1'-10"	2'-0"
42"			9'-9 1/4"	15'-6 3/4"	4'-10 3/4"	1'-9"	2'-6"	2'-4"	2'-6"
48"			9'-9 1/4"	15'-6 3/4"	4'-10 3/4"	2'-0"	3'-0"	2'-10"	3'-0"
60"	40'-0"	15"	9'-8 1/4"	15'-5 3/4"	5'-2"	2'-0"	3'-9"	3'-7"	4'-0"

-Lane's Manufacturing Tolerances per AASHTO M294. -All Dimensions are nominal. (Unless otherwise noted)	PROJECT NAME:	CUSTOMER:	DRAWN BY:	DATE:
	LOCATION:	DESCRIPTION:	JDS	11/28/12
		STANDARD 40' CFT	DRAWING NUMBER:	PAGE:
				2 OF 2



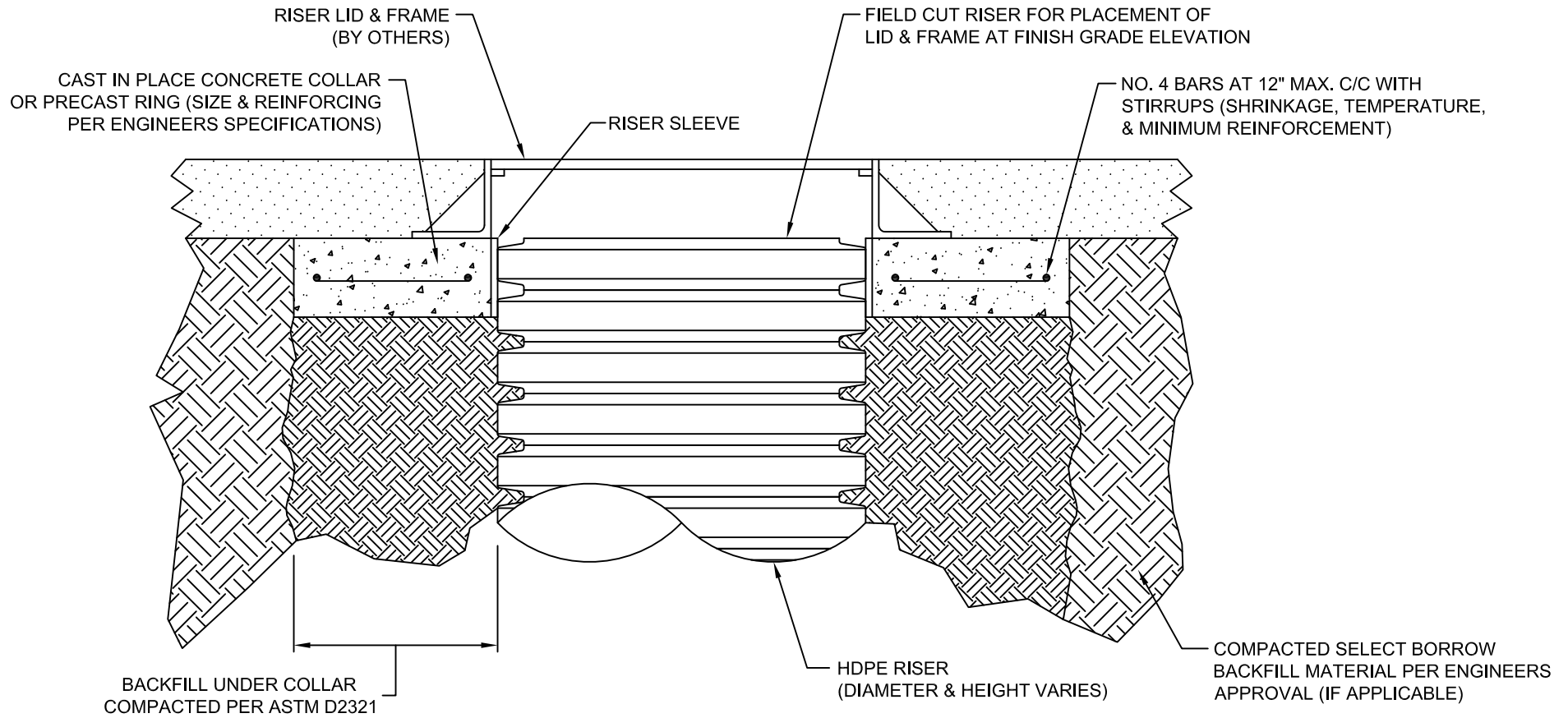

**ELEVATION VIEW**

**Notes:**

1. HDPE Riser Detail To Be Used For Reference, General Construction and Riser Component Layout. HDPE Riser Detail To Be Reviewed And Modified By Project Engineer As Needed For A Specific Project.
2. Utilize Flexible Joint Material For Riser Sleeve. The Material Shall Be Rigid/Stiff Enough To Avoid Deformation When Concrete Is Placed Against The Sleeve. The Sleeve Will Prevent The Concrete From Forming Or Adhering To HDPE Corrugations And Allow For Any Minimal Settlement That May Occur With The Concrete Collar Without Transferring Any Of The Load To The HDPE Riser.
3. Riser Lid & Frame To Be Specified By The Engineer For The Design Project Traffic Loadings (If Applicable). It Is Also Recommended The Lid & Frame Opening Diameter Exceeds The Outside Diameter Of The HDPE Riser By A Maximum Of 3", Permitting The Load Transfer Be On The Concrete Collar Only.
4. If Leveling Courses Of Brick Are Required Between Riser Frame & Concrete Collar, Ensure The Inside Dimensions/Diameter Of The Brick Match The Frame/Concrete Collar Thus Preventing Transfer Of Surface Loads Onto The HDPE Riser.

File Name:	XX	<b>LANE ENTERPRISES, INC.</b>  HDPE RISER INSTALLATION NOTES
Page Number:	1 OF 1	
Date Drawn:	4/30/12	
Drawn By:	JDS	



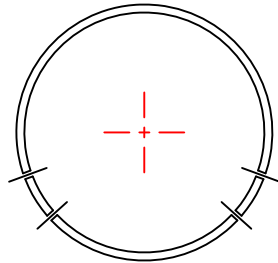

6" - 10" PIPE

DOUBLE WALL PERFORATIONS		
D	d	WIA
6"	0.1875	1.77
8"	0.1875	1.33
10"	0.3125	2.10

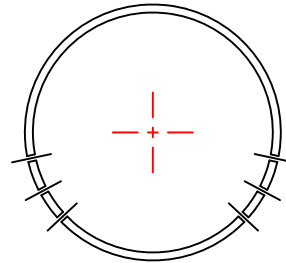

12" - 18" PIPE

DOUBLE WALL PERFORATIONS		
D	d	WIA
12"	0.38	4.10
15"	0.38	3.04
18"	0.38	2.69

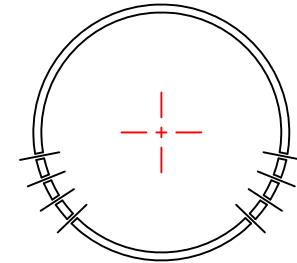

24" - 60" PIPE

DOUBLE WALL PERFORATIONS		
D	d	WIA
24"	0.375	2.68
30"	0.375	2.64
36"	0.375	2.61
42"	0.375	2.00
48"	0.375	2.00
60"	0.375	1.77

**D = Nominal Pipe Diameter (in)**  
**d = Diameter of circular perforation (in)**  
**WIA = Water inlet area (in<sup>2</sup>/ft)**

**CLASS 1 PERFORATIONS (PARTIALLY PERFORATED PIPE)**

Class 1 perforations are for pipe intended to be used for subsurface drainage or combination storm and underdrain. As such, the pipe maintains an unperforated segment above the invert to serve as a flow channel. Perforations are circular and arranged in rows parallel to the axis of the pipe with one perforation in each row for each corrugation. Rows of perforations are arranged in two equal groups placed symmetrically on each side of a lower unperforated segment corresponding to the flow line of the pipe.

File Name:	XX	<b>LANE ENTERPRISES, INC.</b>  CLASS 1 PERFORATIONS
Page Number:	1 OF 2	
Date Drawn:	10-16-15	
Drawn By:	JDS	



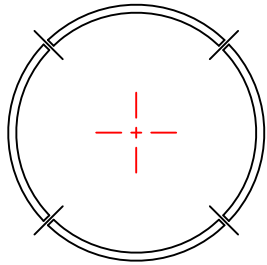

4" - 10" PIPE

SINGLE WALL PERFORATIONS			
D	I	w	WIA
4"	0.783	0.069	4.02
6"	0.769	0.055	2.46
8"	0.759	0.050	1.79
10"	0.779	0.054	1.24

DOUBLE WALL PERFORATIONS			
D	I	w	WIA
6"	0.769	0.055	2.63
8"	0.759	0.050	1.87
10"	0.779	0.054	1.32

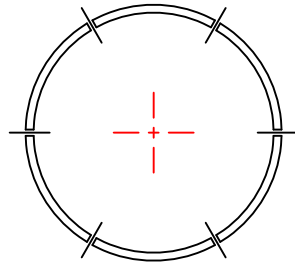

12" - 18" PIPE

DOUBLE WALL PERFORATIONS		
D	d	WIA
12"	0.3125	2.85
15"	0.3125	2.11
18"	0.3125	1.87

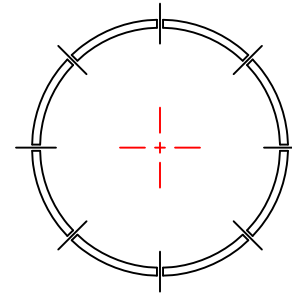

24" - 48" PIPE

DOUBLE WALL PERFORATIONS		
D	d	WIA
24"	0.3750	2.68
30"	0.3750	2.64
36"	0.3750	2.61
42"	0.3750	2.00
48"	0.3750	2.00

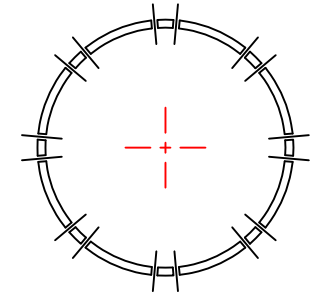

60" PIPE

DOUBLE WALL PERFORATIONS		
D	d	WIA
60"	0.3750	3.53

**D = Nominal Pipe Diameter (in)**  
**I = Average length of slotted perforation (in)**  
**w = Average width of slotted perforation (in)**  
**d = Diameter of circular perforation (in)**  
**WIA = Water inlet area (in<sup>2</sup>/ft)**

**CLASS 2 PERFORATIONS (STANDARD OR FULLY PERFORATED PIPE)**

Class 2 perforations are for pipe intended to be used for subsurface drainage only. Perforations may be circular or slotted and are uniformly spaced along the length and circumference of the pipe. Perforated pipe shall conform to the requirements for Class 2 unless noted otherwise.

File Name:	XX	LANE ENTERPRISES, INC.  CLASS 2 PERFORATIONS
Page Number:	2 OF 2	
Date Drawn:	10-16-15	
Drawn By:	JDS	



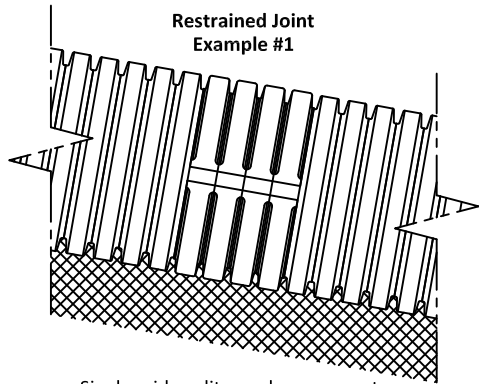

Restrained Joint  
Example #1

Single-wide split coupler engages two corrugations on each side of the joint

Anchoring Example #1  
(Low to moderate demands)

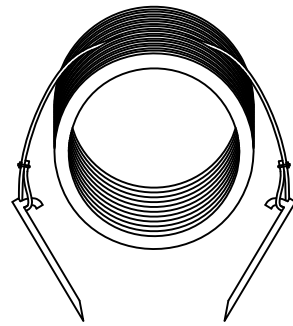

1/8" guy wire, 12"-24"  
metal guy stakes angled  
slightly beneath pipe (all  
components galvanized)

Anchoring Example #2  
(moderate demands)

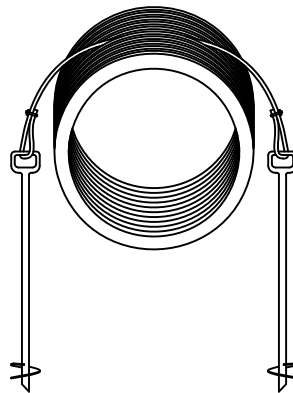

3/8" steel cable, 54"-96"  
guy screw with 8" helix  
& eye (all components  
galvanized)

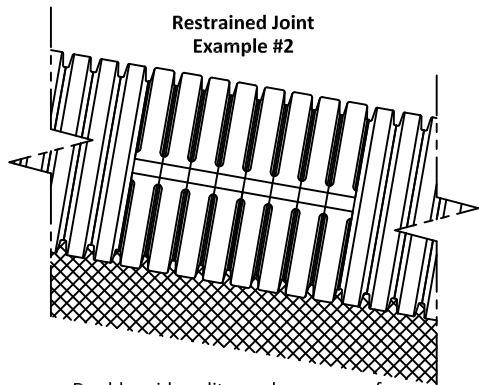

Restrained Joint  
Example #2

Double-wide split coupler engages four corrugations on each side of the joint

Anchoring Example #3  
(moderate to high demands)

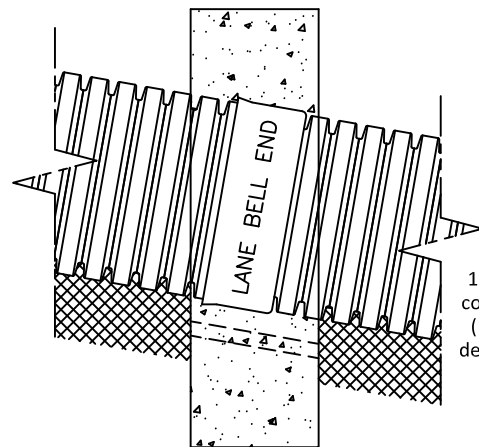

Restrained Joint Example #4  
(bell-and-spigot concrete encasement)

18" thick reinforced  
concrete collar-anchor  
(12" above pipe, 24"  
depth into undisturbed  
soil, 4" weep hole)

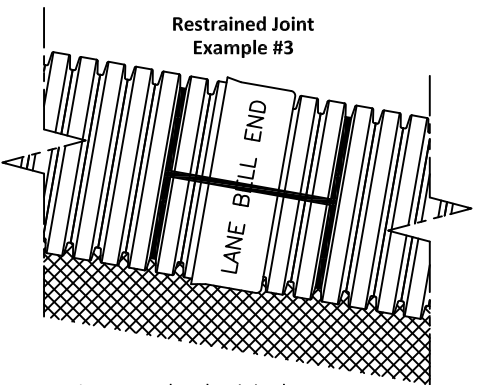

Restrained Joint  
Example #3

Low stretch nylon joint harness straps

**GENERAL**

Slope drains are typically required to mitigate erosion along steep slopes where drainage or groundwater seepage is focused. Since these slopes are prone to erosion and stability issues, slope drains are critical in protecting the public and environmental health, convenience and welfare.

There is no standard practice or definitive guideline to aid the engineering design of slope drains. Each instance is unique with its own challenges and requires an in depth engineering analysis. To the extent possible the engineer of record should provide sufficient pipe capacity, joint integrity, and anchoring. It is generally recommended to over-design a slope drain system to the extent practical when design uncertainties prevail or no provisions are made for an in depth engineering analysis.

Given the critical nature of these facilities and related design challenges, slope drains should be considered temporary structures requiring frequent inspection, maintenance, and upgrades as necessary.

**DESIGN CONSIDERATIONS**

Slope drain laid on grade should be securely anchored into undisturbed soil to provide adequate restraint from any expected internal or external forces, primarily those dynamic forces resultant from water movement. Moderate anchoring is typically achieved by strapping the pipe to embedded guy stakes, while more substantial support can be realized with concrete anchoring systems. Anchoring systems are typically spaced along the pipe length at regular intervals for uniform support.

Additional anchoring considerations should be made for joints, bends, slope changes, inlets and outlets. It should be noted that certain instances may require the pipe to be weighted (e.g. with fill material), and in some cases concrete anchors or thrust blocks may be the best means to prevent movement.

Moderate to comprehensive soils exploration may be needful in determining a suitable anchoring device and the proper placement depth required for firm support.

Pipe joints should be properly restrained from the tendency to pull apart. For corrugated pipes this can be achieved by using corrugated coupling bands. Options to enhance joint restraint include screw fasteners, hose clamps, or other types of hardware as appropriate. Joint integrity may also be improved using appropriately designed poured-in-place concrete collar-anchors.

Consideration should be given towards gasketed bell-and-spigot joints where more stringent joint leakage requirements are desired. Restraint for bell and spigot joints can be provided by a concrete collar-anchor, various hardware options, or low stretch nylon joint harness straps.

Flow velocities through the pipe should be lessened to the extent possible. Options for corrugated HDPE pipe include using a single wall pipe (i.e. corrugated interior) as opposed to a double-wall (smooth interior) pipe.

**It shall be the responsibility of the presiding site engineer to evaluate the suitability of any concepts depicted or otherwise noted on this sheet.**

SCALE:	NTS
DRAWN BY:	JDS
DATE:	10/26/12
DRAWING NUMBER:	

PAGE:

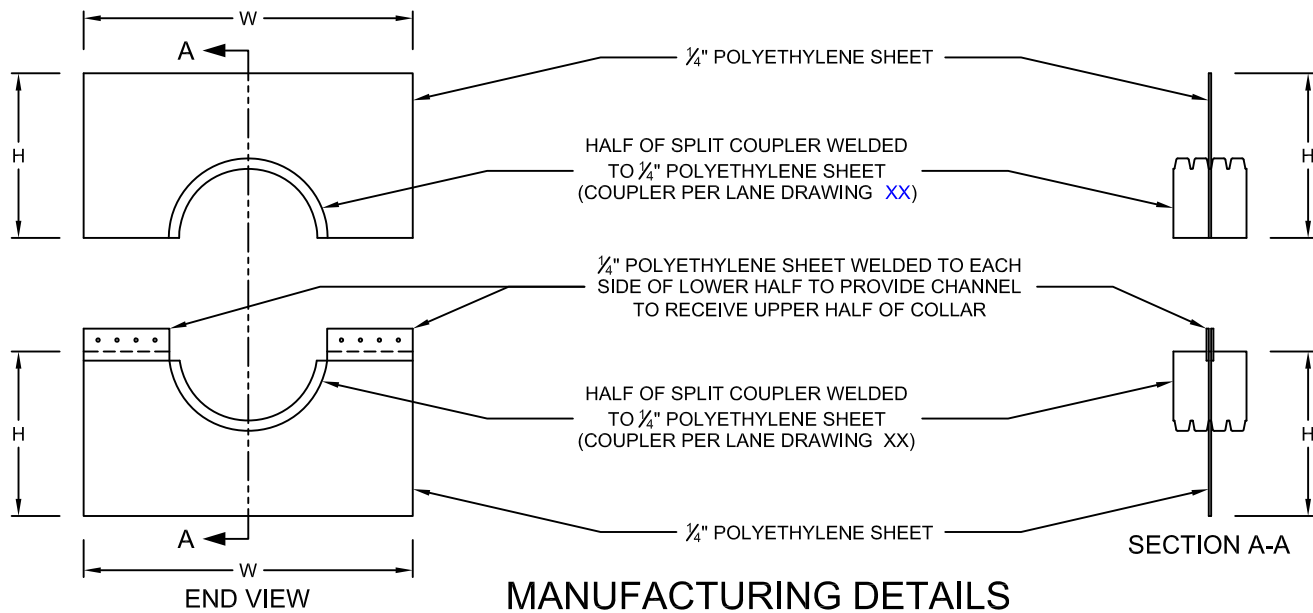

**MANUFACTURING DETAILS**

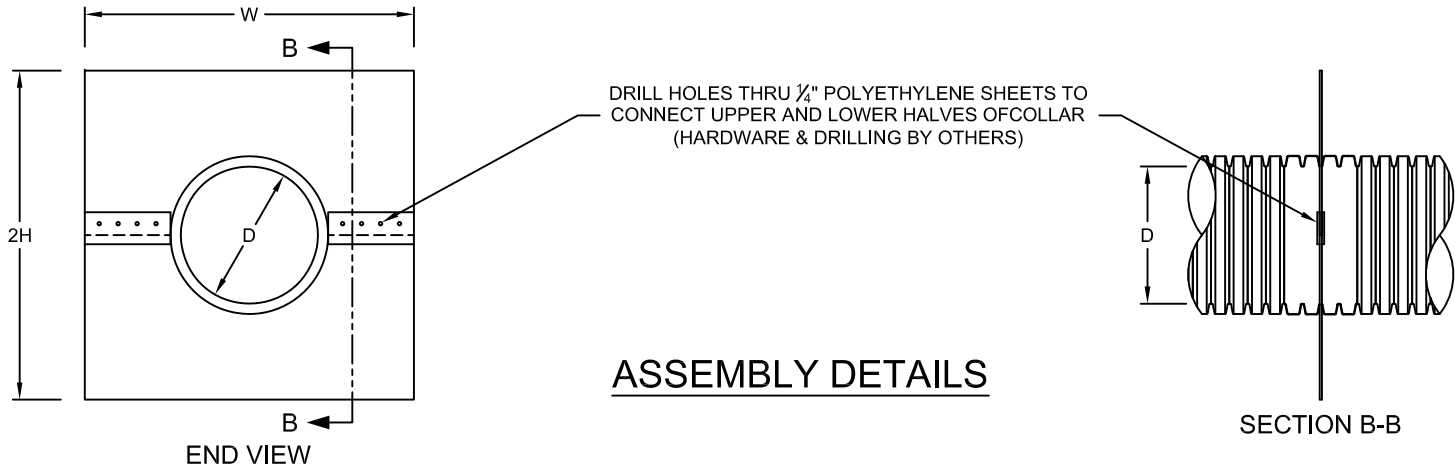

**ASSEMBLY DETAILS**

ANTI-SEEP COLLAR SPECIFICATIONS			
NUMBER REQUIRED	DIAMETER (D)	WIDTH (W)	HEIGHT (H)

NOTE: ALL FITTING DIMENSIONS ARE FOR REFERENCE ONLY.

File Name:	XXX	LANE ENTERPRISES, INC.  HDPE ANTI-SEEP COLLAR
Page Number:	1 OF 1	
Date Drawn:	12-3-12	
Drawn By:	JDS	



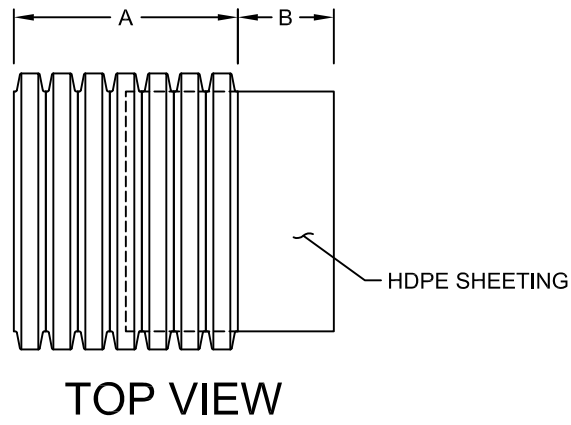

TOP VIEW

PIPE SIZE	PART #	A	B
10"	<a href="#">HDFT10RCPDWADPT/S</a>	10.75"	6.00"
12"	<a href="#">HDFT12RCPDWADPT/S</a>	13.75"	6.00"
15"	<a href="#">HDFT15RCPDWADPT/S</a>	18.00"	6.00"
18"	<a href="#">HDFT18RCPDWADPT/S</a>	22.75"	9.00"
24"	<a href="#">HDFT24RCPDWADPT/S</a>	27.50"	9.00"
30"	<a href="#">HDFT30RCPDWADPT/S</a>	28.00"	9.00"
36"	<a href="#">HDFT36RCPDWADPT/S</a>	28.00"	12.00"
42"	<a href="#">HDFT42RCPDWADPT/S</a>	37.25"	12.00"
48"	<a href="#">HDFT48RCPDWADPT/S</a>	37.25"	12.00"
60"	<a href="#">HDFT60RCPDWADPT/S</a>	42.00"	12.00"

NOTE: ALL FITTING DIMENSIONS ARE FOR REFERENCE ONLY.

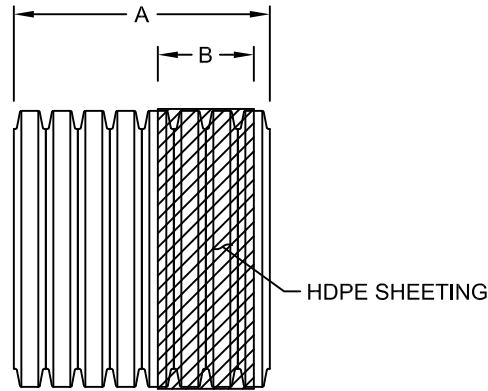

TOP VIEW

PIPE SIZE	PART #	A	B
10"	<a href="#">HDFT10RCPMHADPT/S</a>	17.00"	7.75"
12"	<a href="#">HDFT12RCPMHADPT/S</a>	17.75"	7.75"
15"	<a href="#">HDFT15RCPMHADPT/S</a>	20.75"	7.75"
18"	<a href="#">HDFT18RCPMHADPT/S</a>	23.75"	9.00"
24"	<a href="#">HDFT24RCPMHADPT/S</a>	31.50"	11.75"
30"	<a href="#">HDFT30RCPMHADPT/S</a>	32.00"	12.00"
36"	<a href="#">HDFT36RCPMHADPT/S</a>	32.00"	12.00"
42"	<a href="#">HDFT42RCPMHADPT/S</a>	42.75"	16.00"
48"	<a href="#">HDFT48RCPMHADPT/S</a>	42.75"	16.00"
60"	<a href="#">HDFT60RCPMHADPT/S</a>	48.00"	16.00"

NOTE: ALL FITTING DIMENSIONS ARE FOR REFERENCE ONLY.

File Name:	XX	LANE ENTERPRISES, INC.  DUAL WALL MANHOLE ADAPTER	
Page Number:	1 OF 1		
Date Drawn:	10-16-15		
Drawn By:	JDS		

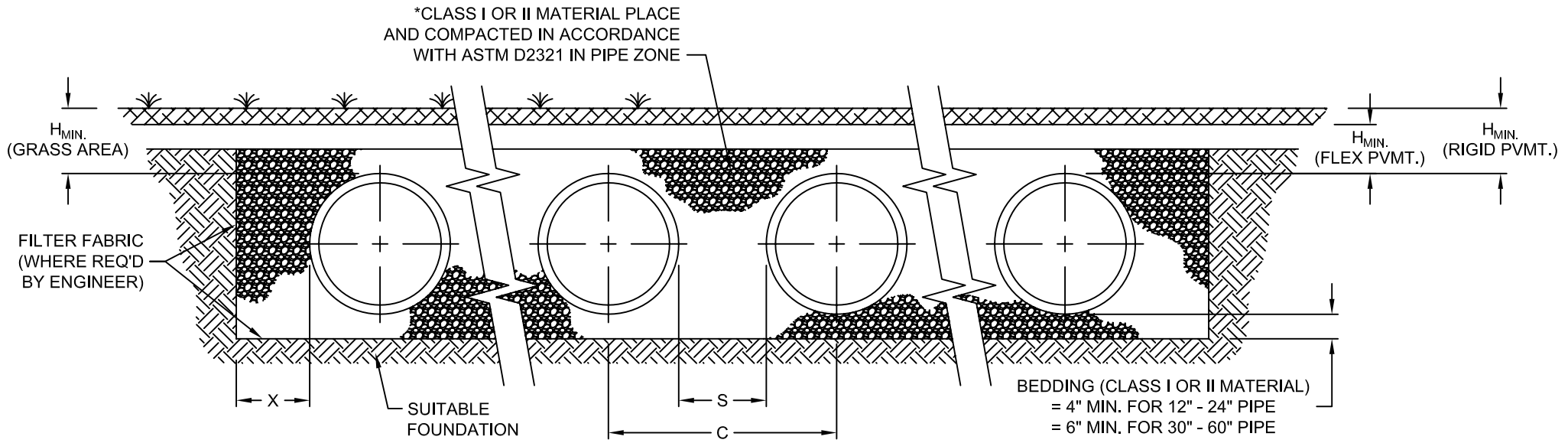

### TYPICAL CROSS SECTION

Notes:

1. The drawing and table is intended to identify standard dimensioning used for Lane corrugated HDPE pipe retention and detention systems.
2. Retention and detention systems shall be installed in a manner consistent with the standard practice used for corrugated HDPE pipe installations, ASTM D2321, and the manufacturer's published installation guidelines. All references to Class I or Class II material per the latest edition of ASTM D2321.
3. It should be noted that proper backfill placement and compaction in the haunch regions of fittings are less trivial than for straight pipe segments and that additional scrutiny may be needed to ensure the same.
4. Typical side wall dimensions shown in the table are suggested minimums to ensure sufficient clearance for the proper placement and compaction of backfill materials and apply only for stable trench walls. The dimension shall be increased consistent with standard installation practices when unstable materials are encountered.
5. Minimum cover heights shown are more conservative than that used for straight pipe segments and are applicable to system fittings. A buoyancy analysis may indicate the need for additional cover where the seasonal high ground water elevation becomes a factor.
6. Maximum cover heights are limited to 8 feet above the top of fittings for standard installations. Consult a Lane representative when deeper fill heights are anticipated.

NOMINAL DIAMETER	NOMINAL O.D.	TYPICAL SPACING "S"	TYPICAL SPACING "C"	TYPICAL SIDE WALL "X"	H <sub>MIN.</sub> (NON-TRAFFIC)	H <sub>MIN.</sub> (TRAFFIC)
12"	14.5"	9.00"	23.50"	8"	12"	12"
15"	17.5"	13.50"	31.00"	8"	12"	12"
18"	21.5"	14.00"	35.50"	9"	12"	12"
24"	28.0"	19.25"	47.25"	10"	12"	12"
30"	34.5"	21.50"	56.00"	15"	12"	12"
36"	41.0"	23.00"	64.00"	15"	12"	12"
42"	47.5"	27.25"	74.75"	15"	12"	24"
48"	54.5"	20.25"	74.75"	15"	12"	24"
60"	66.8"	23.25"	90.00"	15"	12"	24"

\*CLASS I BACKFILL REQUIRED AROUND ALL 60" DIAMETER FITTINGS.

File Name:	XX
Page Number:	1 OF 1
Date Drawn:	8/5/14
Drawn By:	JDS

**LANE ENTERPRISES, INC.**

TYPICAL RETENTION/DETENTION CROSS SECTION DETAIL



6" REDUCER TEE					
PART NUMBER	STUB	A	B	C	D
SWCB06T/031	6"	39.74"	36.66"	29.61"	19.87"

8" REDUCER TEE					
PART NUMBER	STUB	A	B	C	D
SWCB08X06RT/031	6"	39.84"	39.01"	29.61"	19.92"
SWCB08T/031	8"	39.84"	38.55"	29.15"	19.92"

10" REDUCER TEE					
PART NUMBER	STUB	A	B	C	D
SWCB10X06RT/031	6"	40.00"	41.61"	29.61"	20.00"
SWCB10X08RT/031	8"	40.00"	41.15"	29.15"	20.00"
SWCB10T/031	10"	40.00"	41.23"	29.23"	20.00"

12" REDUCER TEE					
PART NUMBER	STUB	A	B	C	D
SWCB12X06RT/031	6"	39.34"	44.19"	29.61"	19.67"
SWCB12X08RT/031	8"	39.34"	43.73"	29.15"	19.67"
SWCB12X10RT/031	10"	39.34"	43.81"	29.23"	19.67"
SWCB12T/031	12"	39.34"	44.09"	29.51"	19.67"

15" REDUCER TEE					
PART NUMBER	STUB	A	B	C	D
SWCB15X06RT/031	6"	38.71"	47.34"	29.61"	19.36"
SWCB15X08RT/031	8"	38.71"	46.88"	29.15"	19.36"
SWCB15X10RT/031	10"	38.71"	46.96"	29.23"	19.36"
SWCB15X12RT/031	12"	38.71"	47.24"	29.51"	19.36"

18" REDUCER TEE					
PART NUMBER	STUB	A	B	C	D
SWCB18X06RT/031	6"	41.48"	51.06"	29.61"	20.74"
SWCB18X08RT/031	8"	41.48"	50.60"	29.15"	20.74"
SWCB18X10RT/031	10"	41.48"	50.68"	29.32"	20.74"
SWCB18X12RT/031	12"	41.48"	50.96"	29.51"	20.74"

24" REDUCER TEE					
PART NUMBER	STUB	A	B	C	D
SWCB24X06RT/031	6"	39.34"	57.81"	29.61"	19.67"
SWCB24X08RT/031	8"	39.34"	57.35"	29.15"	19.67"
SWCB24X10RT/031	10"	39.34"	57.43"	29.23"	19.67"
SWCB24X12RT/031	12"	39.34"	57.71"	29.51"	19.67"

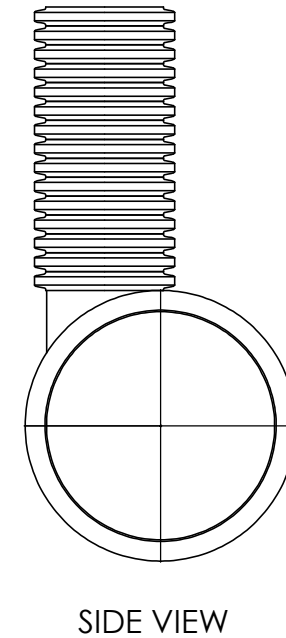
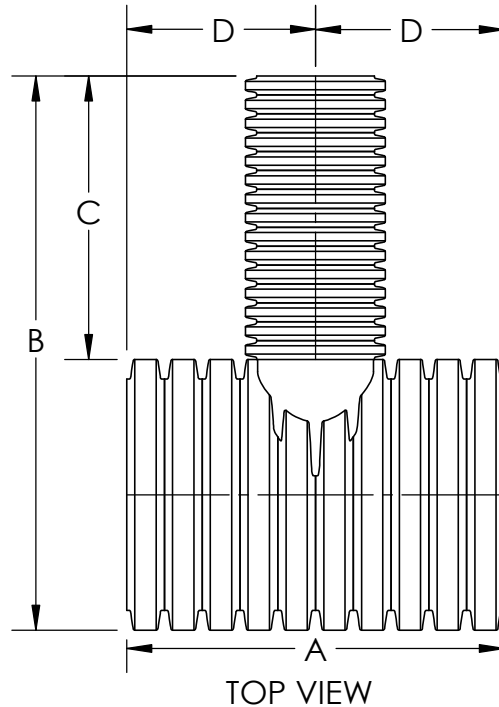

NOTE: ALL FITTING DIMENSIONS ARE FOR REFERENCE ONLY.

File Name:	SK31 SGL TEE TABULATION	LANE ENTERPRISES, INC.	
Page Number:	1 OF 1	SK31 MANIFOLD SINGLE TEE	
Date Drawn:	6/21/20		
Drawn By:	JBM		

6" REDUCER TEE						
PART NUMBER	STUB	A	B	C	D	E
SWCB06TX2/031	6"	80.26"	36.66"	29.61"	20.26"	39.74"

8" REDUCER TEE						
PART NUMBER	STUB	A	B	C	D	E
SWCB08X06RTX2/031	6"	79.68"	39.01"	29.61"	19.22"	39.84"
SWCB08TX2/031	8"	79.68"	38.55"	29.15"	19.22"	39.84"

10" REDUCER TEE						
PART NUMBER	STUB	A	B	C	D	E
SWCB10X06RTX2/031	6"	80.00"	41.61"	29.61"	20.00"	40.00"
SWCB10X08RTX2/031	8"	80.00"	41.15"	29.15"	20.00"	40.00"
SWCB10TX2/031	10"	80.00"	41.23"	29.23"	20.00"	40.00"

12" REDUCER TEE						
PART NUMBER	STUB	A	B	C	D	E
SWCB12X06RTX2/031	6"	78.69"	44.19"	29.61"	19.67"	39.34"
SWCB12X08RTX2/031	8"	78.69"	43.73"	29.15"	19.67"	39.34"
SWCB12X10RTX2/031	10"	78.69"	43.81"	29.32"	19.67"	39.34"
SWCB12TX2/031	12"	78.69"	44.09"	29.51"	19.67"	39.34"

15" REDUCER TEE						
PART NUMBER	STUB	A	B	C	D	E
SWCB15X06RTX2/031	6"	80.00"	47.34"	29.61"	20.66"	38.71"
SWCB15X08RTX2/031	8"	80.00"	46.88"	29.15"	20.66"	38.71"
SWCB15X10RTX2/031	10"	80.00"	46.96"	29.32"	20.66"	38.71"
SWCB15X12RTX2/031	12"	80.00"	47.24"	29.51"	20.66"	38.71"

18" REDUCER TEE						
PART NUMBER	STUB	A	B	C	D	E
SWCB18X06RTX2/031	6"	80.00"	51.06"	29.61"	19.26"	41.48"
SWCB18X08RTX2/031	8"	80.00"	50.60"	29.15"	19.26"	41.48"
SWCB18X10RTX2/031	10"	80.00"	50.68"	29.32"	19.26"	41.48"
SWCB18X12RTX2/031	12"	80.00"	50.96"	29.51"	19.26"	41.48"

24" REDUCER TEE						
PART NUMBER	STUB	A	B	C	D	E
SWCB24X06RTX2/031	6"	78.69"	57.81"	29.61"	19.67"	39.34"
SWCB24X08RTX2/031	8"	78.69"	57.35"	29.15"	19.67"	39.34"
SWCB24X10RTX2/031	10"	78.69"	57.43"	29.32"	19.67"	39.34"
SWCB24X12RTX2/031	12"	78.69"	57.71"	29.51"	19.67"	39.34"

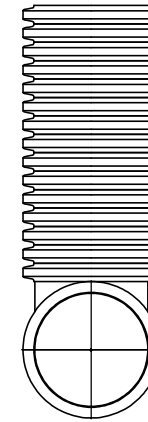
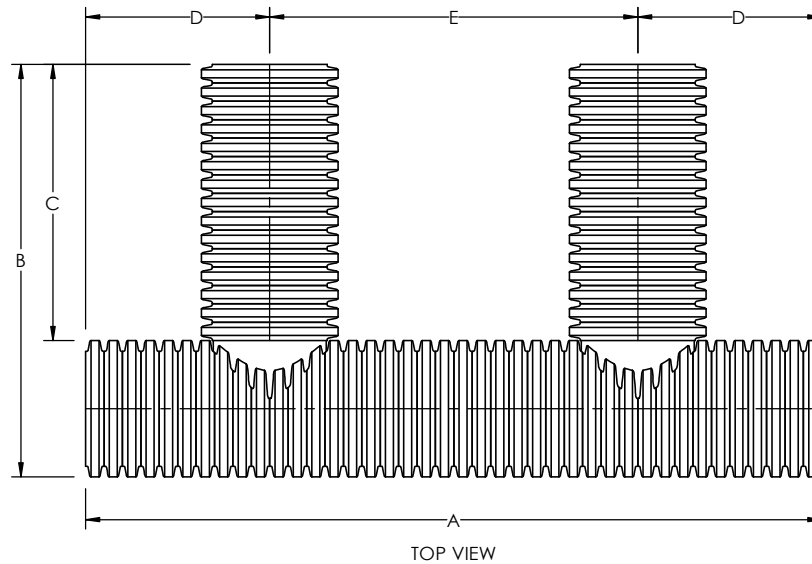

SIDE VIEW

NOTE: ALL FITTING DIMENSIONS ARE FOR REFERENCE ONLY.

File Name:	SK31 DBL TEE TABULATED	<b>LANE ENTERPRISES, INC.</b>  SK31 MANIFOLD DOUBLE TEE TABULATED
Page Number:	1 OF 1	
Date Drawn:	6/22/2020	
Drawn By:	JBM	



6" REDUCER TEE						
PART NUMBER	STUB	A	B	C	D	F
SWCB06TX3/031	6"	120.00"	36.66"	29.61"	20.26"	39.74"

8" REDUCER TEE						
PART NUMBER	STUB	A	B	C	D	F
SWCB08X06RTX3/031	6"	119.51"	39.01"	29.61"	19.92"	39.84"
SWCB08TX3/031	8"	119.51"	38.55"	29.15"	19.92"	39.84"

10" REDUCER TEE						
PART NUMBER	STUB	A	B	C	D	F
SWCB10X06RTX3/031	6"	120.00"	41.61"	29.61"	20.00"	40.00"
SWCB10X08RTX3/031	8"	120.00"	41.15"	29.15"	20.00"	40.00"
SWCB10TX3/031	10"	120.00"	41.32"	29.32"	20.00"	40.00"

12" REDUCER TEE						
PART NUMBER	STUB	A	B	C	D	F
SWCB12X06RTX3/031	6"	120.00"	44.19"	29.61"	19.67"	40.33"
SWCB12X08RTX3/031	8"	120.00"	43.73"	29.15"	19.67"	40.33"
SWCB12X10RTX3/031	10"	120.00"	43.90"	29.32"	19.67"	40.33"
SWCB12TX3/031	12"	120.00"	44.09"	29.51"	19.67"	40.33"

15" REDUCER TEE						
PART NUMBER	STUB	A	B	C	D	F
SWCB15X06RTX3/031	6"	118.71"	47.34"	29.61"	19.36"	40.00"
SWCB15X08RTX3/031	8"	118.71"	46.88"	29.15"	19.36"	40.00"
SWCB15X10RTX3/031	10"	118.71"	47.05"	29.32"	19.36"	40.00"
SWCB15X12RTX3/031	12"	118.71"	47.24"	29.51"	19.36"	40.00"

18" REDUCER TEE						
PART NUMBER	STUB	A	B	C	D	F
SWCB18X06RTX3/031	6"	118.52"	51.06"	29.61"	20.74"	38.52"
SWCB18X08RTX3/031	8"	118.52"	50.60"	29.15"	20.74"	38.52"
SWCB18X10RTX3/031	10"	118.52"	50.77"	29.32"	20.74"	38.52"
SWCB18X12RTX3/031	12"	118.52"	50.96"	29.51"	20.74"	38.52"

24" REDUCER TEE						
PART NUMBER	STUB	A	B	C	D	F
SWCB24X06RTX3/031	6"	118.03"	57.81"	29.61"	19.67"	39.34"
SWCB24X08RTX3/031	8"	118.03"	57.35"	29.15"	19.67"	39.34"
SWCB24X10RTX3/031	10"	118.03"	57.52"	29.32"	19.67"	39.34"
SWCB24X12RTX3/031	12"	118.03"	57.71"	29.51"	19.67"	39.34"

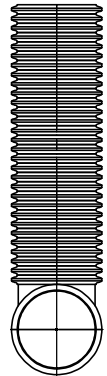
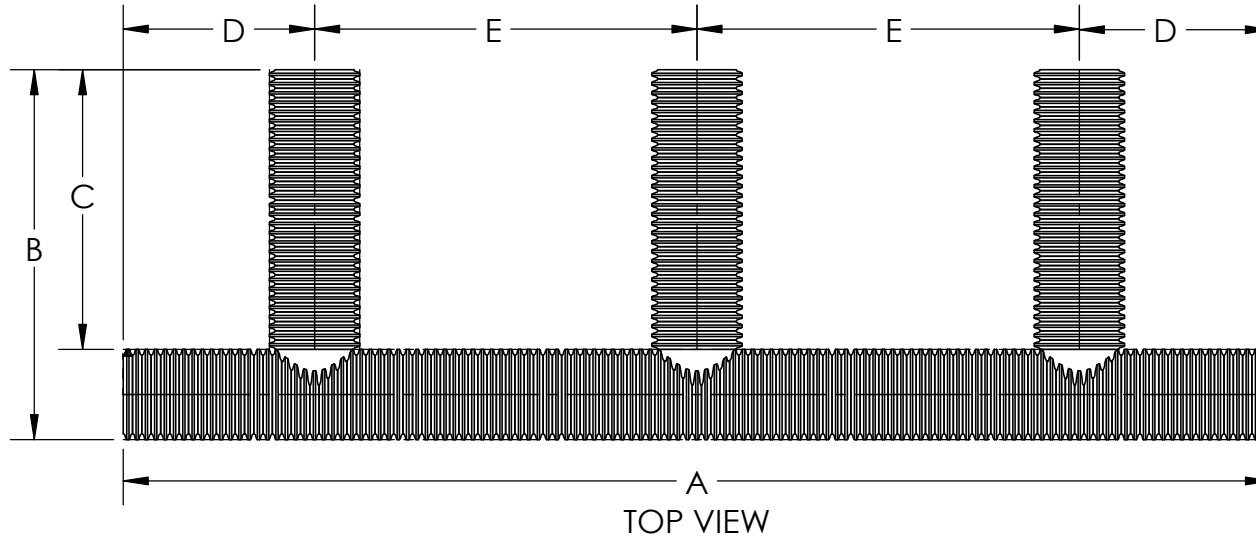

SIDE VIEW

NOTE: ALL FITTING DIMENSIONS ARE FOR REFERENCE ONLY.

File Name:	SK31 TPL TEE TABULATED	LANE ENTERPRISES, INC.
Page Number:	1 OF 1	SK31 MANIFOLD TRIPLE TEE
Date Drawn:	6/23/20	
Drawn By:	JBM	



8" REDUCER TEE					
PART #	STUB	A	B	C	D
SWCB08X04RT/075	4"	57.25"	46.25"	36.75"	28.63"
SWCB08X06RT/075	6"	57.25"	46.00"	36.50"	28.63"
SWCB08T/075	8"	57.25"	46.50"	37.00"	28.63"

10" REDUCER TEE					
PART #	STUB	A	B	C	D
SWCB10X04RT/075	4"	57.00"	48.75"	36.75"	28.5"
SWCB10X06RT/075	6"	57.00"	48.50"	36.50"	28.5"
SWCB10X08RT/075	8"	57.00"	49.00"	37.00"	28.5"
SWCB10T/075	10"	57.00"	49.00"	37.00"	28.5"

12" REDUCER TEE					
PART #	STUB	A	B	C	D
SWCB12X04RT/075	4"	57.00"	51.25"	36.75"	28.5"
SWCB12X06RT/075	6"	57.00"	51.00"	36.50"	28.5"
SWCB12X08RT/075	8"	57.00"	51.50"	37.00"	28.5"
SWCB12X10RT/075	10"	57.00"	51.50"	37.00"	28.5"
SWCB12T/075	12"	57.00"	52.00"	37.50"	28.5"

15" REDUCER TEE					
PART #	STUB	A	B	C	D
SWCB15X04RT/075	4"	56.75"	54.25"	36.75"	28.38"
SWCB15X06RT/075	6"	56.75"	54.00"	36.50"	28.38"
SWCB15X08RT/075	8"	56.75"	54.50"	37.00"	28.38"
SWCB15X10RT/075	10"	56.75"	54.50"	37.00"	28.38"
SWCB15X12RT/075	12"	56.75"	55.00"	37.50"	28.38"
SWCB15T/075	15"	56.75"	53.75"	36.25"	28.38"

18" REDUCER TEE					
PART #	STUB	A	B	C	D
SWCB18X04RT/075	4"	56.25"	58.25"	36.75"	28.13"
SWCB18X06RT/075	6"	56.25"	58.00"	36.50"	28.13"
SWCB18X08RT/075	8"	56.25"	58.50"	37.00"	28.13"
SWCB18X10RT/075	10"	56.25"	58.50"	37.00"	28.13"
SWCB18X12RT/075	12"	56.25"	59.00"	37.50"	28.13"
SWCB18X15RT/075	15"	56.25"	57.75"	36.25"	28.13"
SWCB18T/075	18"	56.25"	60.00"	38.50"	28.13"

24" REDUCER TEE					
PART #	STUB	A	B	C	D
SWCB24X04RT/075	4"	59.00"	64.75"	36.75"	29.50"
SWCB24X06RT/075	6"	59.00"	64.50"	36.50"	29.50"
SWCB24X08RT/075	8"	59.00"	65.00"	37.00"	29.50"
SWCB24X10RT/075	10"	59.00"	65.00"	37.00"	29.50"
SWCB24X12RT/075	12"	59.00"	65.50"	37.50"	29.50"
SWCB24X15RT/075	15"	59.00"	64.25"	36.25"	29.50"
SWCB24X18RT/075	18"	59.00"	66.50"	38.50"	29.50"

30" REDUCER TEE					
PART #	STUB	A	B	C	D
SWCB30X04RT/075	4"	58.00"	71.25"	36.75"	28.00"
SWCB30X06RT/075	6"	58.00"	71.00"	36.50"	28.00"
SWCB30X08RT/075	8"	58.00"	71.50"	37.00"	28.00"
SWCB30X10RT/075	10"	58.00"	71.50"	37.00"	28.00"
SWCB30X12RT/075	12"	58.00"	72.00"	37.50"	28.00"
SWCB30X15RT/075	15"	58.00"	70.75"	36.25"	28.00"
SWCB30X18RT/075	18"	58.00"	73.00"	38.50"	28.00"

36" REDUCER TEE					
PART #	STUB	A	B	C	D
SWCB36X04RT/075	4"	58.00"	77.75"	36.75"	28.00"
SWCB36X06RT/075	6"	58.00"	77.50"	36.50"	28.00"
SWCB36X08RT/075	8"	58.00"	78.00"	37.00"	28.00"
SWCB36X10RT/075	10"	58.00"	78.00"	37.00"	28.00"
SWCB36X12RT/075	12"	58.00"	78.50"	37.50"	28.00"
SWCB36X15RT/075	15"	58.00"	77.25"	36.25"	28.00"
SWCB36X18RT/075	18"	58.00"	79.50"	38.50"	28.00"

42" REDUCER TEE					
PART #	STUB	A	B	C	D
SWCB42X04RT/075	4"	58.75"	84.25"	36.75"	29.38"
SWCB42X06RT/075	6"	58.75"	84.00"	36.50"	29.38"
SWCB42X08RT/075	8"	58.75"	84.50"	37.00"	29.38"
SWCB42X10RT/075	10"	58.75"	84.50"	37.00"	29.38"
SWCB42X12RT/075	12"	58.75"	85.00"	37.50"	29.38"
SWCB42X15RT/075	15"	58.75"	83.75"	36.25"	29.38"
SWCB42X18RT/075	18"	58.75"	86.00"	38.50"	29.38"

48" REDUCER TEE					
PART #	STUB	A	B	C	D
SWCB48X04RT/075	4"	58.75"	91.25"	36.75"	29.38"
SWCB48X06RT/075	6"	58.75"	91.00"	36.50"	29.38"
SWCB48X08RT/075	8"	58.75"	91.50"	37.00"	29.38"
SWCB48X10RT/075	10"	58.75"	91.50"	37.00"	29.38"
SWCB48X12RT/075	12"	58.75"	92.00"	37.50"	29.38"
SWCB48X15RT/075	15"	58.75"	90.75"	36.25"	29.38"
SWCB48X18RT/075	18"	58.75"	93.00"	38.50"	29.38"

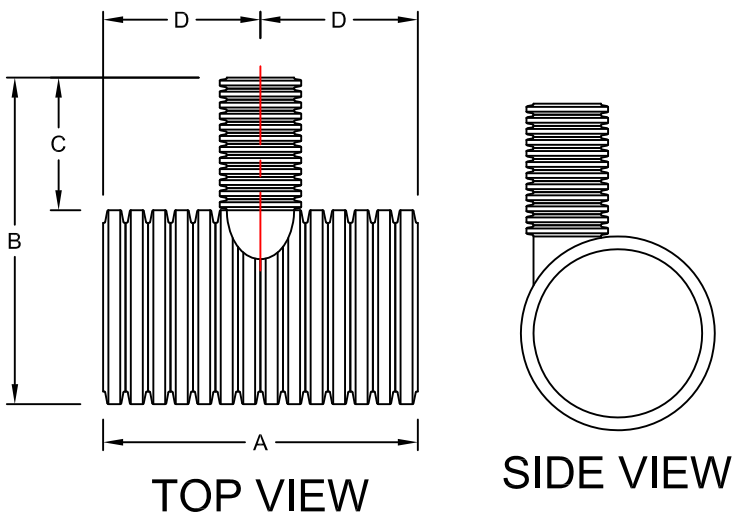

NOTE: ALL FITTING DIMENSIONS ARE FOR REFERENCE ONLY.

File Name:	SK75 SINGLE
Page Number:	1 OF 1
Date Drawn:	2/26/15
Drawn By:	JDS

LANE ENTERPRISES, INC.

SK75 MANIFOLD SINGLE TEE



**8" REDUCER TEE**

PART #	STUB	A	B	C	D	E
SWCB08X04RTX2/075	4"	113.75"	46.25"	36.75"	28.50"	56.75"
SWCB08X06RTX2/075	6"	113.75"	46.00"	36.50"	28.50"	56.75"
SWCB08TX2/075	8"	113.75"	46.50"	37.00"	28.50"	56.75"

**10" REDUCER TEE**

PART #	STUB	A	B	C	D	E
SWCB10X04RTX2/075	4"	113.75"	48.75"	36.75"	28.50"	57.00"
SWCB10X06RTX2/075	6"	113.75"	48.50"	36.50"	28.50"	57.00"
SWCB10X08RTX2/075	8"	113.75"	49.00"	37.00"	28.50"	57.00"
SWCB10TX2/075	10"	113.75"	49.00"	37.00"	28.50"	57.00"

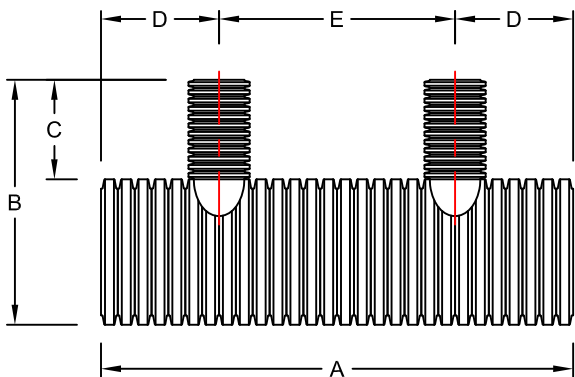

**TOP VIEW**

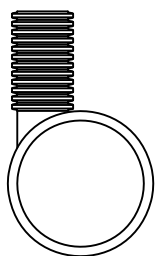

**SIDE VIEW**

NOTE: ALL FITTING DIMENSIONS ARE FOR REFERENCE ONLY.

**12" REDUCER TEE**

PART #	STUB	A	B	C	D	E
SWCB12X04RTX2/075	4"	114.00"	51.25"	36.75"	28.50"	57.00"
SWCB12X06RTX2/075	6"	114.00"	51.00"	36.50"	28.50"	57.00"
SWCB12X08RTX2/075	8"	114.00"	51.50"	37.00"	28.50"	57.00"
SWCB12X10RTX2/075	10"	114.00"	51.50"	37.00"	28.50"	57.00"
SWCB12TX2/075	12"	114.00"	52.00"	37.50"	28.50"	57.00"

**15" REDUCER TEE**

PART #	STUB	A	B	C	D	E
SWCB15X04RTX2/075	4"	113.50"	54.25"	36.75"	28.50"	56.75"
SWCB15X06RTX2/075	6"	113.50"	54.00"	36.50"	28.50"	56.75"
SWCB15X08RTX2/075	8"	113.50"	54.50"	37.00"	28.50"	56.75"
SWCB15X10RTX2/075	10"	113.50"	54.50"	37.00"	28.50"	56.75"
SWCB15X12RTX2/075	12"	113.50"	55.00"	37.50"	28.50"	56.75"
SWCB15TX2/075	15"	113.50"	53.75"	36.25"	28.50"	56.75"

**18" REDUCER TEE**

PART #	STUB	A	B	C	D	E
SWCB18X04RTX2/075	4"	112.50"	58.25"	36.75"	28.25"	56.25"
SWCB18X06RTX2/075	6"	112.50"	58.00"	36.50"	28.25"	56.25"
SWCB18X08RTX2/075	8"	112.50"	58.50"	37.00"	28.25"	56.25"
SWCB18X10RTX2/075	10"	112.50"	58.50"	37.00"	28.25"	56.25"
SWCB18X12RTX2/075	12"	112.50"	59.00"	37.50"	28.25"	56.25"
SWCB18X15RTX2/075	15"	112.50"	57.75"	36.25"	28.25"	56.25"
SWCB18TX2/075	18"	112.50"	60.00"	38.50"	28.25"	56.25"

**24" REDUCER TEE**

PART #	STUB	A	B	C	D	E
SWCB24X04RTX2/075	4"	114.00"	64.75"	36.75"	28.50"	57.00"
SWCB24X06RTX2/075	6"	114.00"	64.50"	36.50"	28.50"	57.00"
SWCB24X08RTX2/075	8"	114.00"	65.00"	37.00"	28.50"	57.00"
SWCB24X10RTX2/075	10"	114.00"	65.00"	37.00"	28.50"	57.00"
SWCB24X12RTX2/075	12"	114.00"	65.50"	37.50"	28.50"	57.00"
SWCB24X15RTX2/075	15"	114.00"	64.25"	36.25"	28.50"	57.00"
SWCB24X18RTX2/075	18"	114.00"	66.50"	38.50"	28.50"	57.00"

**30" REDUCER TEE**

PART #	STUB	A	B	C	D	E
SWCB30X04RTX2/075	4"	116.00"	71.25"	36.75"	29.00"	58.00"
SWCB30X06RTX2/075	6"	116.00"	71.00"	36.50"	29.00"	58.00"
SWCB30X08RTX2/075	8"	116.00"	71.50"	37.00"	29.00"	58.00"
SWCB30X10RTX2/075	10"	116.00"	71.50"	37.00"	29.00"	58.00"
SWCB30X12RTX2/075	12"	116.00"	72.00"	37.50"	29.00"	58.00"
SWCB30X15RTX2/075	15"	116.00"	70.75"	36.25"	29.00"	58.00"
SWCB30X18RTX2/075	18"	116.00"	73.00"	38.50"	29.00"	58.00"

**36" REDUCER TEE**

PART #	STUB	A	B	C	D	E
SWCB36X04RTX2/075	4"	116.00"	77.75"	36.75"	29.00"	58.00"
SWCB36X06RTX2/075	6"	116.00"	77.50"	36.50"	29.00"	58.00"
SWCB36X08RTX2/075	8"	116.00"	78.00"	37.00"	29.00"	58.00"
SWCB36X10RTX2/075	10"	116.00"	78.00"	37.00"	29.00"	58.00"
SWCB36X12RTX2/075	12"	116.00"	78.50"	37.50"	29.00"	58.00"
SWCB36X15RTX2/075	15"	116.00"	77.25"	36.25"	29.00"	58.00"
SWCB36X18RTX2/075	18"	116.00"	79.50"	38.50"	29.00"	58.00"

**42" REDUCER TEE**

PART #	STUB	A	B	C	D	E
SWCB42X04RTX2/075	4"	112.00"	84.25"	36.75"	28.00"	56.00"
SWCB42X06RTX2/075	6"	112.00"	84.00"	36.50"	28.00"	56.00"
SWCB42X08RTX2/075	8"	112.00"	84.50"	37.00"	28.00"	56.00"
SWCB42X10RTX2/075	10"	112.00"	84.50"	37.00"	28.00"	56.00"
SWCB42X12RTX2/075	12"	112.00"	85.00"	37.50"	28.00"	56.00"
SWCB42X15RTX2/075	15"	112.00"	83.75"	36.25"	28.00"	56.00"
SWCB42X18RTX2/075	18"	112.00"	86.00"	38.50"	28.00"	56.00"

**48" REDUCER TEE**

PART #	STUB	A	B	C	D	E
SWCB48X04RTX2/075	4"	112.00"	91.25"	36.75"	28.00"	56.00"
SWCB48X06RTX2/075	6"	112.00"	91.00"	36.50"	28.00"	56.00"
SWCB48X08RTX2/075	8"	112.00"	91.50"	37.00"	28.00"	56.00"
SWCB48X10RTX2/075	10"	112.00"	91.50"	37.00"	28.00"	56.00"
SWCB48X12RTX2/075	12"	112.00"	92.00"	37.50"	28.00"	56.00"
SWCB48X15RTX2/075	15"	112.00"	90.75"	36.25"	28.00"	56.00"
SWCB48X18RTX2/075	18"	112.00"	93.00"	38.50"	28.00"	56.00"

**LANE ENTERPRISES, INC.**

**SK75 MANIFOLD DOUBLE TEE**



File Name:	SK75 DOUBLE
Page Number:	1 OF 1
Date Drawn:	2/26/15
Drawn By:	JDS

8" REDUCER TEE						
PART #	STUB	A	B	C	D	E
SWCB08X04RTX3/075	4"	171.00"	46.25"	36.75"	28.50"	57.00"
SWCB08X06RTX3/075	6"	171.00"	46.00"	36.50"	28.50"	57.00"
SWCB08X08RTX3/075	8"	171.00"	46.50"	37.00"	28.50"	57.00"

10" REDUCER TEE						
PART #	STUB	A	B	C	D	E
SWCB10X04RTX3/075	4"	170.75"	48.75"	36.75"	28.50"	57.00"
SWCB10X06RTX3/075	6"	170.75"	48.50"	36.50"	28.50"	57.00"
SWCB10X08RTX3/075	8"	170.75"	49.00"	37.00"	28.50"	57.00"
SWCB10TX3/075	10"	170.75"	49.00"	37.00"	28.50"	57.00"

12" REDUCER TEE						
PART #	STUB	A	B	C	D	E
SWCB12X04RTX3/075	4"	171.25"	51.25"	36.75"	28.50"	57.00"
SWCB12X06RTX3/075	6"	171.25"	51.00"	36.50"	28.50"	57.00"
SWCB12X08RTX3/075	8"	171.25"	51.50"	37.00"	28.50"	57.00"
SWCB12X10RTX3/075	10"	171.25"	51.50"	37.00"	28.50"	57.00"
SWCB12TX3/075	12"	171.25"	52.00"	37.50"	28.50"	57.00"

30" REDUCER TEE						
PART #	STUB	A	B	C	D	E
SWCB30X04RTX3/075	4"	172.00"	71.25"	36.75"	28.75"	57.25"
SWCB30X06RTX3/075	6"	172.00"	71.00"	36.50"	28.75"	57.25"
SWCB30X08RTX3/075	8"	172.00"	71.50"	37.00"	28.75"	57.25"
SWCB30X10RTX3/075	10"	172.00"	71.50"	37.00"	28.75"	57.25"
SWCB30X12RTX3/075	12"	172.00"	72.00"	37.50"	28.75"	57.25"
SWCB30X15RTX3/075	15"	172.00"	70.75"	36.25"	28.75"	57.25"
SWCB30X18RTX3/075	18"	172.00"	73.00"	38.50"	28.75"	57.25"

15" REDUCER TEE						
PART #	STUB	A	B	C	D	E
SWCB15X04RTX3/075	4"	170.25"	54.25"	36.75"	28.50"	56.75"
SWCB15X06RTX3/075	6"	170.25"	54.00"	36.50"	28.50"	56.75"
SWCB15X08RTX3/075	8"	170.25"	54.50"	37.00"	28.50"	56.75"
SWCB15X10RTX3/075	10"	170.25"	54.50"	37.00"	28.50"	56.75"
SWCB15X12RTX3/075	12"	170.25"	55.00"	37.50"	28.50"	56.75"
SWCB15TX3/075	15"	170.25"	53.75"	36.25"	28.50"	56.75"

36" REDUCER TEE						
PART #	STUB	A	B	C	D	E
SWCB36X04RTX3/075	4"	172.00"	77.75"	36.75"	28.75"	57.25"
SWCB36X06RTX3/075	6"	172.00"	77.50"	36.50"	28.75"	57.25"
SWCB36X08RTX3/075	8"	172.00"	78.00"	37.00"	28.75"	57.25"
SWCB36X10RTX3/075	10"	172.00"	78.00"	37.00"	28.75"	57.25"
SWCB36X12RTX3/075	12"	172.00"	78.50"	37.50"	28.75"	57.25"
SWCB36X15RTX3/075	15"	172.00"	77.25"	36.25"	28.75"	57.25"
SWCB36X18RTX3/075	18"	172.00"	79.50"	38.50"	28.75"	57.25"

18" REDUCER TEE						
PART #	STUB	A	B	C	D	E
SWCB18X04RTX3/075	4"	171.75"	58.25"	36.75"	28.75"	57.25"
SWCB18X06RTX3/075	6"	171.75"	58.00"	36.50"	28.75"	57.25"
SWCB18X08RTX3/075	8"	171.75"	58.50"	37.00"	28.75"	57.25"
SWCB18X10RTX3/075	10"	171.75"	58.50"	37.00"	28.75"	57.25"
SWCB18X12RTX3/075	12"	171.75"	59.00"	37.50"	28.75"	57.25"
SWCB18X15RTX3/075	15"	171.75"	57.75"	36.25"	28.75"	57.25"
SWCB18TX3/075	18"	171.75"	60.00"	38.50"	28.75"	57.25"

42" REDUCER TEE						
PART #	STUB	A	B	C	D	E
SWCB42X04RTX3/075	4"	170.75"	84.25"	36.75"	28.50"	57.00"
SWCB42X06RTX3/075	6"	170.75"	84.00"	36.50"	28.50"	57.00"
SWCB42X08RTX3/075	8"	170.75"	84.50"	37.00"	28.50"	57.00"
SWCB42X10RTX3/075	10"	170.75"	84.50"	37.00"	28.50"	57.00"
SWCB42X12RTX3/075	12"	170.75"	85.00"	37.50"	28.50"	57.00"
SWCB42X15RTX3/075	15"	170.75"	83.75"	36.25"	28.50"	57.00"
SWCB42X18RTX3/075	18"	170.75"	86.00"	38.50"	28.50"	57.00"

24" REDUCER TEE						
PART #	STUB	A	B	C	D	E
SWCB24X04RTX3/075	4"	169.25"	64.75"	36.75"	28.25"	56.50"
SWCB24X06RTX3/075	6"	169.25"	64.50"	36.50"	28.25"	56.50"
SWCB24X08RTX3/075	8"	169.25"	65.00"	37.00"	28.25"	56.50"
SWCB24X10RTX3/075	10"	169.25"	65.00"	37.00"	28.25"	56.50"
SWCB24X12RTX3/075	12"	169.25"	65.50"	37.50"	28.25"	56.50"
SWCB24X15RTX3/075	15"	169.25"	64.25"	36.25"	28.25"	56.50"
SWCB24X18RTX3/075	18"	169.25"	66.50"	38.50"	28.25"	56.50"

48" REDUCER TEE						
PART #	STUB	A	B	C	D	E
SWCB48X04RTX3/075	4"	170.75"	91.25"	36.75"	28.50"	57.00"
SWCB48X06RTX3/075	6"	170.75"	91.00"	36.50"	28.50"	57.00"
SWCB48X08RTX3/075	8"	170.75"	91.50"	37.00"	28.50"	57.00"
SWCB48X10RTX3/075	10"	170.75"	91.50"	37.00"	28.50"	57.00"
SWCB48X12RTX3/075	12"	170.75"	92.00"	37.50"	28.50"	57.00"
SWCB48X15RTX3/075	15"	170.75"	90.75"	36.25"	28.50"	57.00"
SWCB48X18RTX3/075	18"	170.75"	93.00"	38.50"	28.50"	57.00"

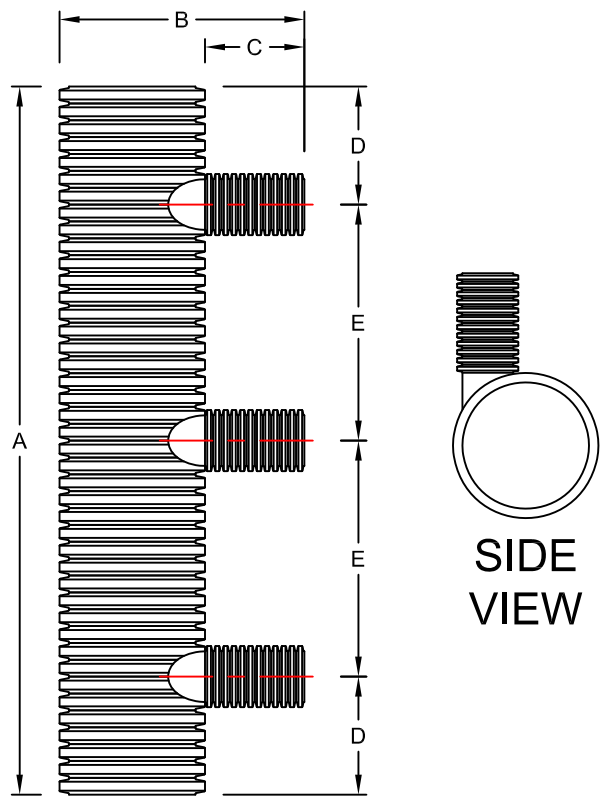

**SIDE VIEW**

**TOP VIEW**

NOTE: ALL FITTING DIMENSIONS ARE FOR REFERENCE ONLY.

File Name:	SK75 TRIPLE
Page Number:	1 OF 1
Date Drawn:	2/26/15
Drawn By:	JDS

**LANE ENTERPRISES, INC.**

**SK75 MANIFOLD TRIPLE TEE**



8" REDUCER TEE					
PART #	STUB	A	B	C	D
SWCB08X04RT/180	4"	85.50"	46.25"	36.75"	42.75"
SWCB08X06RT/180	6"	85.50"	46.00"	36.50"	42.75"
SWCB08T/180	8"	85.50"	46.50"	37.00"	42.75"

10" REDUCER TEE					
PART #	STUB	A	B	C	D
SWCB10X04RT/180	4"	86.25"	48.75"	36.75"	43.13"
SWCB10X06RT/180	6"	86.25"	48.50"	36.50"	43.13"
SWCB10X08RT/180	8"	86.25"	49.00"	37.00"	43.13"
SWCB10T/180	10"	86.25"	49.00"	37.00"	43.13"

12" REDUCER TEE					
PART #	STUB	A	B	C	D
SWCB12X04RT/180	4"	86.50"	51.25"	36.75"	43.25"
SWCB12X06RT/180	6"	86.50"	51.00"	36.50"	43.25"
SWCB12X08RT/180	8"	86.50"	51.50"	37.00"	43.25"
SWCB12X10RT/180	10"	86.50"	51.50"	37.00"	43.25"
SWCB12T/180	12"	86.50"	52.00"	37.50"	43.25"

15" REDUCER TEE					
PART #	STUB	A	B	C	D
SWCB15X04RT/180	4"	85.25"	54.25"	36.75"	42.63"
SWCB15X06RT/180	6"	85.25"	54.00"	36.50"	42.63"
SWCB15X08RT/180	8"	85.25"	54.50"	37.00"	42.63"
SWCB15X10RT/180	10"	85.25"	54.50"	37.00"	42.63"
SWCB15X12RT/180	12"	85.25"	55.00"	37.50"	42.63"
SWCB15T/180	15"	85.25"	53.75"	36.25"	42.63"

18" REDUCER TEE					
PART #	STUB	A	B	C	D
SWCB18X04RT/180	4"	86.00"	58.25"	36.75"	43.00"
SWCB18X06RT/180	6"	86.00"	58.00"	36.50"	43.00"
SWCB18X08RT/180	8"	86.00"	58.50"	37.00"	43.00"
SWCB18X10RT/180	10"	86.00"	58.50"	37.00"	43.00"
SWCB18X12RT/180	12"	86.00"	59.00"	37.50"	43.00"
SWCB18X15RT/180	15"	86.00"	57.75"	36.25"	43.00"
SWCB18T/180	18"	86.00"	60.00"	38.50"	43.00"

24" REDUCER TEE					
PART #	STUB	A	B	C	D
SWCB24X04RT/180	4"	86.50"	64.75"	36.75"	43.25"
SWCB24X06RT/180	6"	86.50"	64.50"	36.50"	43.25"
SWCB24X08RT/180	8"	86.50"	65.00"	37.00"	43.25"
SWCB24X10RT/180	10"	86.50"	65.00"	37.00"	43.25"
SWCB24X12RT/180	12"	86.50"	65.50"	37.50"	43.25"
SWCB24X15RT/180	15"	86.50"	64.25"	36.25"	43.25"
SWCB24X18RT/180	18"	86.50"	66.50"	38.50"	43.25"
SWCB24T/180	24"	86.50"	67.25"	39.25"	43.25"

30" REDUCER TEE					
PART #	STUB	A	B	C	D
SWCB30X04RT/180	4"	84.00"	71.25"	36.75"	42.00"
SWCB30X06RT/180	6"	84.00"	71.00"	36.50"	42.00"
SWCB30X08RT/180	8"	84.00"	71.50"	37.00"	42.00"
SWCB30X10RT/180	10"	84.00"	71.50"	37.00"	42.00"
SWCB30X12RT/180	12"	84.00"	72.00"	37.50"	42.00"
SWCB30X15RT/180	15"	84.00"	70.75"	36.25"	42.00"
SWCB30X18RT/180	18"	84.00"	73.00"	38.50"	42.00"
SWCB30X24RT/180	24"	84.00"	73.75"	39.25"	42.00"
SWCB30T/180	30"	84.00"	70.50"	36.00"	42.00"

36" REDUCER TEE					
PART #	STUB	A	B	C	D
SWCB36X04RT/180	4"	84.00"	77.75"	36.75"	42.00"
SWCB36X06RT/180	6"	84.00"	77.50"	36.50"	42.00"
SWCB36X08RT/180	8"	84.00"	78.00"	37.00"	42.00"
SWCB36X10RT/180	10"	84.00"	78.00"	37.00"	42.00"
SWCB36X12RT/180	12"	84.00"	78.50"	37.50"	42.00"
SWCB36X15RT/180	15"	84.00"	77.25"	36.25"	42.00"
SWCB36X18RT/180	18"	84.00"	79.50"	38.50"	42.00"
SWCB36X24RT/180	24"	84.00"	80.25"	39.25"	42.00"
SWCB36T/180	30"	84.00"	77.00"	36.00"	42.00"

42" REDUCER TEE					
PART #	STUB	A	B	C	D
SWCB42X04RT/180	4"	85.25"	84.25"	36.75"	42.63"
SWCB42X06RT/180	6"	85.25"	84.00"	36.50"	42.63"
SWCB42X08RT/180	8"	85.25"	84.50"	37.00"	42.63"
SWCB42X10RT/180	10"	85.25"	84.50"	37.00"	42.63"
SWCB42X12RT/180	12"	85.25"	85.00"	37.50"	42.63"
SWCB42X15RT/180	15"	85.25"	83.75"	36.25"	42.63"
SWCB42X18RT/180	18"	85.25"	86.00"	38.50"	42.63"
SWCB42X24RT/180	24"	85.25"	86.75"	39.25"	42.63"
SWCB42T/180	30"	85.25"	83.50"	36.00"	42.63"

48" REDUCER TEE					
PART #	STUB	A	B	C	D
SWCB48X04RT/180	4"	85.25"	91.25"	36.75"	42.63"
SWCB48X06RT/180	6"	85.25"	91.00"	36.50"	42.63"
SWCB48X08RT/180	8"	85.25"	91.50"	37.00"	42.63"
SWCB48X10RT/180	10"	85.25"	91.50"	37.00"	42.63"
SWCB48X12RT/180	12"	85.25"	92.00"	37.50"	42.63"
SWCB48X15RT/180	15"	85.25"	90.75"	36.25"	42.63"
SWCB48X18RT/180	18"	85.25"	93.00"	38.50"	42.63"
SWCB48X24RT/180	24"	85.25"	93.75"	39.25"	42.63"
SWCB48T/180	30"	85.25"	90.50"	36.00"	42.63"

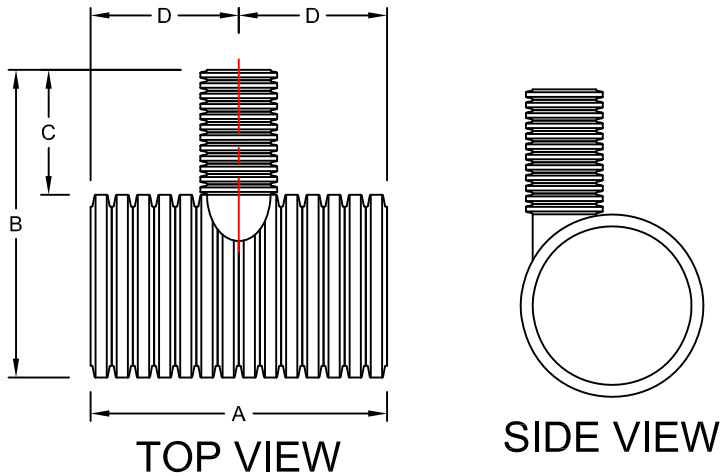

NOTE: ALL FITTING DIMENSIONS ARE FOR REFERENCE ONLY.

LANE ENTERPRISES, INC.

File Name:	SK180 SINGLE
Page Number:	1 OF 1
Date Drawn:	2/26/15
Drawn By:	JDS

SK180 MANIFOLD SINGLE TEE



8" REDUCER TEE						
PART #	STUB	A	B	C	D	E
SWCB08X04RTX2/180	4"	172.00"	46.25"	36.75"	43.00"	86.00"
SWCB08X06RTX2/180	6"	172.00"	46.00"	36.50"	43.00"	86.00"
SWCB08TX2/180	8"	172.00"	46.50"	37.00"	43.00"	86.00"

10" REDUCER TEE						
PART #	STUB	A	B	C	D	E
SWCB10X04RTX2/180	4"	172.25"	48.75"	36.75"	43.00"	86.25"
SWCB10X06RTX2/180	6"	172.25"	48.50"	36.50"	43.00"	86.25"
SWCB10X08RTX2/180	8"	172.25"	49.00"	37.00"	43.00"	86.25"
SWCB10TX2/180	10"	172.25"	49.00"	37.00"	43.00"	86.25"

12" REDUCER TEE						
PART #	STUB	A	B	C	D	E
SWCB12X04RTX2/180	4"	171.25"	51.25"	36.75"	42.75"	85.50"
SWCB12X06RTX2/180	6"	171.25"	51.00"	36.50"	42.75"	85.50"
SWCB12X08RTX2/180	8"	171.25"	51.50"	37.00"	42.75"	85.50"
SWCB12X10RTX2/180	10"	171.25"	51.50"	37.00"	42.75"	85.50"
SWCB12TX2/180	12"	171.25"	52.00"	37.50"	42.75"	85.50"

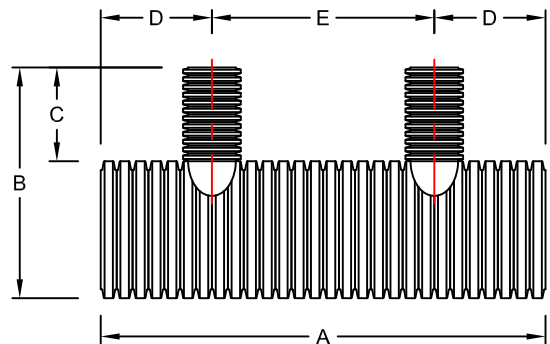

TOP VIEW

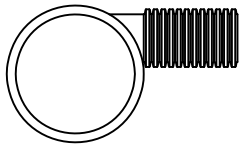

SIDE VIEW

NOTE: ALL FITTING DIMENSIONS ARE FOR REFERENCE ONLY.

15" REDUCER TEE						
PART #	STUB	A	B	C	D	E
SWCB15X04RTX2/180	4"	170.25"	54.25"	36.75"	42.50"	85.25"
SWCB15X06RTX2/180	6"	170.25"	54.00"	36.50"	42.50"	85.25"
SWCB15X08RTX2/180	8"	170.25"	54.50"	37.00"	42.50"	85.25"
SWCB15X10RTX2/180	10"	170.25"	54.50"	37.00"	42.50"	85.25"
SWCB15X12RTX2/180	12"	170.25"	55.00"	37.50"	42.50"	85.25"
SWCB15TX2/180	15"	170.25"	53.75"	36.25"	42.50"	85.25"

18" REDUCER TEE						
PART #	STUB	A	B	C	D	E
SWCB18X04RTX2/180	4"	171.75"	58.25"	36.75"	43.00"	86.00"
SWCB18X06RTX2/180	6"	171.75"	58.00"	36.50"	43.00"	86.00"
SWCB18X08RTX2/180	8"	171.75"	58.50"	37.00"	43.00"	86.00"
SWCB18X10RTX2/180	10"	171.75"	58.50"	37.00"	43.00"	86.00"
SWCB18X12RTX2/180	12"	171.75"	59.00"	37.50"	43.00"	86.00"
SWCB18X15RTX2/180	15"	171.75"	57.75"	36.25"	43.00"	86.00"
SWCB18TX2/180	18"	171.75"	60.00"	38.50"	43.00"	86.00"

24" REDUCER TEE						
PART #	STUB	A	B	C	D	E
SWCB24X04RTX2/180	4"	173.00"	64.75"	36.75"	43.25"	86.50"
SWCB24X06RTX2/180	6"	173.00"	64.50"	36.50"	43.25"	86.50"
SWCB24X08RTX2/180	8"	173.00"	65.00"	37.00"	43.25"	86.50"
SWCB24X10RTX2/180	10"	173.00"	65.00"	37.00"	43.25"	86.50"
SWCB24X12RTX2/180	12"	173.00"	65.50"	37.50"	43.25"	86.50"
SWCB24X15RTX2/180	15"	173.00"	64.25"	36.25"	43.25"	86.50"
SWCB24X18RTX2/180	18"	173.00"	66.50"	38.50"	43.25"	86.50"
SWCB24TX2/180	24"	173.00"	67.25"	39.25"	43.25"	86.50"

30" REDUCER TEE						
PART #	STUB	A	B	C	D	E
SWCB30X04RTX2/180	4"	172.00"	71.25"	36.75"	43.00"	86.00"
SWCB30X06RTX2/180	6"	172.00"	71.00"	36.50"	43.00"	86.00"
SWCB30X08RTX2/180	8"	172.00"	71.50"	37.00"	43.00"	86.00"
SWCB30X10RTX2/180	10"	172.00"	71.50"	37.00"	43.00"	86.00"
SWCB30X12RTX2/180	12"	172.00"	72.00"	37.50"	43.00"	86.00"
SWCB30X15RTX2/180	15"	172.00"	70.75"	36.25"	43.00"	86.00"
SWCB30X18RTX2/180	18"	172.00"	73.00"	38.50"	43.00"	86.00"
SWCB30X24RTX2/180	24"	172.00"	73.75"	39.25"	43.00"	86.00"
SWCB30TX2/180	30"	172.00"	70.50"	36.00"	43.00"	86.00"

36" REDUCER TEE						
PART #	STUB	A	B	C	D	E
SWCB36X04RTX2/180	4"	172.00"	77.75"	36.75"	43.00"	86.00"
SWCB36X06RTX2/180	6"	172.00"	77.50"	36.50"	43.00"	86.00"
SWCB36X08RTX2/180	8"	172.00"	78.00"	37.00"	43.00"	86.00"
SWCB36X10RTX2/180	10"	172.00"	78.00"	37.00"	43.00"	86.00"
SWCB36X12RTX2/180	12"	172.00"	78.50"	37.50"	43.00"	86.00"
SWCB36X15RTX2/180	15"	172.00"	77.25"	36.25"	43.00"	86.00"
SWCB36X18RTX2/180	18"	172.00"	79.50"	38.50"	43.00"	86.00"
SWCB36X24RTX2/180	24"	172.00"	80.25"	39.25"	43.00"	86.00"
SWCB36X30RTX2/180	30"	172.00"	77.00"	36.00"	43.00"	86.00"

42" REDUCER TEE						
PART #	STUB	A	B	C	D	E
SWCB42X04RTX2/180	4"	170.75"	84.25"	36.75"	42.75"	85.25"
SWCB42X06RTX2/180	6"	170.75"	84.00"	36.50"	42.75"	85.25"
SWCB42X08RTX2/180	8"	170.75"	84.50"	37.00"	42.75"	85.25"
SWCB42X10RTX2/180	10"	170.75"	84.50"	37.00"	42.75"	85.25"
SWCB42X12RTX2/180	12"	170.75"	85.00"	37.50"	42.75"	85.25"
SWCB42X15RTX2/180	15"	170.75"	83.75"	36.25"	42.75"	85.25"
SWCB42X18RTX2/180	18"	170.75"	86.00"	38.50"	42.75"	85.25"
SWCB42X24RTX2/180	24"	170.75"	86.75"	39.25"	42.75"	85.25"
SWCB42X30RTX2/180	30"	170.75"	83.50"	36.00"	42.75"	85.25"

48" REDUCER TEE						
PART #	STUB	A	B	C	D	E
SWCB48X04RTX2/180	4"	170.75"	91.25"	36.75"	42.75"	85.25"
SWCB48X06RTX2/180	6"	170.75"	91.00"	36.50"	42.75"	85.25"
SWCB48X08RTX2/180	8"	170.75"	91.50"	37.00"	42.75"	85.25"
SWCB48X10RTX2/180	10"	170.75"	91.50"	37.00"	42.75"	85.25"
SWCB48X12RTX2/180	12"	170.75"	92.00"	37.50"	42.75"	85.25"
SWCB48X15RTX2/180	15"	170.75"	90.75"	36.25"	42.75"	85.25"
SWCB48X18RTX2/180	18"	170.75"	93.00"	38.50"	42.75"	85.25"
SWCB48X24RTX2/180	24"	170.75"	93.75"	39.25"	42.75"	85.25"
SWCB48X30RTX2/180	30"	170.75"	90.50"	36.00"	42.75"	85.25"

File Name:	SK180 DOUBLE
Page Number:	1 OF 1
Date Drawn:	2/26/15
Drawn By:	JDS

LANE ENTERPRISES, INC.

SK180 MANIFOLD DOUBLE TEE



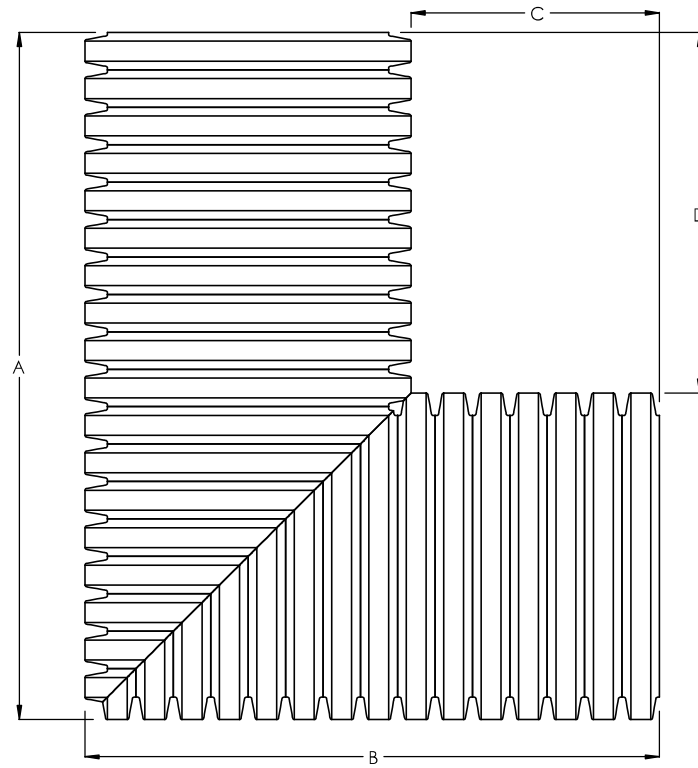

PIPE SIZE	PART #	A	B	C	D
6"	SWCB06EL90/31	36.25"	23.78"	16.73"	29.20"
8"	SWCB08EL90/31	38.71"	25.10"	15.70"	29.31"
10"	SWCB10EL90/31	41.38"	26.00"	14.00"	29.38"
12"	SWCB12EL90/31	42.69"	26.96"	12.38"	28.12"

NOTE: ALL FITTING DIMENSIONS ARE FOR REFERENCE ONLY.

File Name:	SK31 ELBOW	<b>LANE ENTERPRISES, INC.</b>  SK31 MANIFOLD 90° ELBOW
Page Number:	1 OF 1	
Date Drawn:	6/24/2020	
Drawn By:	JBM	



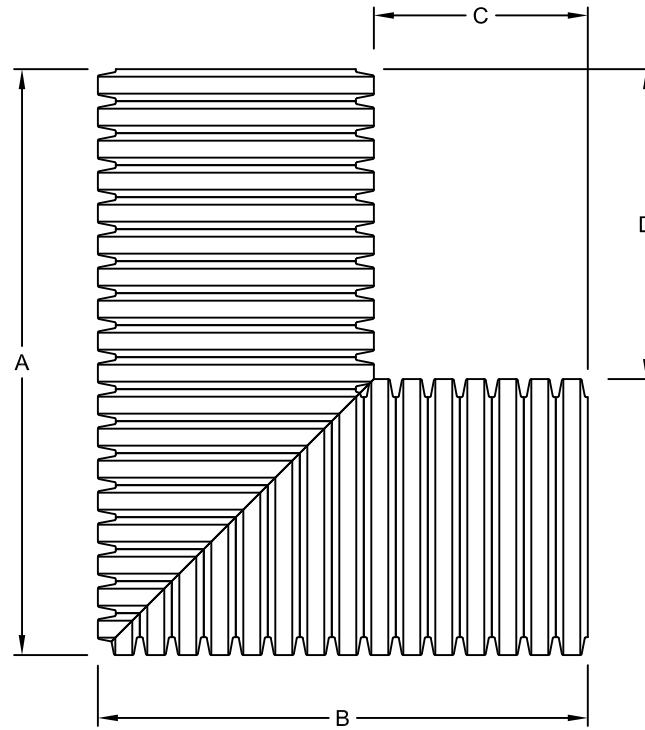

TOP VIEW

PIPE SIZE	PART #	A	B	C	D
8"	<a href="#">SWCB08EL90/075</a>	45.50"	34.00"	24.50"	36.00"
10"	<a href="#">SWCB10EL90/075</a>	49.00"	37.25"	23.75"	37.00"
12"	<a href="#">SWCB12EL90/075</a>	50.50"	36.75"	22.25"	36.00"
15"	<a href="#">SWCB15EL90/075</a>	55.25"	37.25"	19.75"	37.75"
18"	<a href="#">SWCB18EL90/075</a>	58.25"	40.50"	19.00"	36.75"

NOTE: ALL FITTING DIMENSIONS ARE FOR REFERENCE ONLY.

File Name:	SK75 ELBOW	<b>LANE ENTERPRISES, INC.</b>  SK75 MANIFOLD 90° ELBOW
Page Number:	1 OF 1	
Date Drawn:	7/30/15	
Drawn By:	JDS	



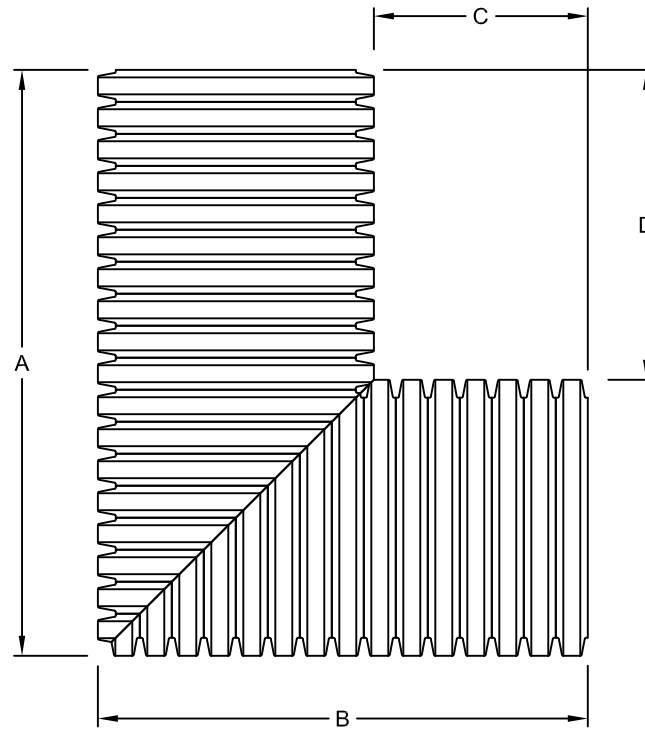

TOP VIEW

PIPE SIZE	PART #	A	B	C	D
8"	<a href="#">SWCB08EL90/180</a>	45.50"	48.50"	39.00"	36.00"
10"	<a href="#">SWCB10EL90/180</a>	49.00"	49.00"	37.00"	37.00"
12"	<a href="#">SWCB12EL90/180</a>	50.50"	50.50"	36.00"	36.00"
15"	<a href="#">SWCB15EL90/180</a>	55.25"	52.50"	35.00"	37.75"
18"	<a href="#">SWCB18EL90/180</a>	58.25"	55.25"	33.75"	36.75"
24"	<a href="#">SWCB24EL90/180</a>	65.25"	57.25"	29.25"	37.25"
30"	<a href="#">SWCB30EL90/180</a>	73.25"	61.25"	26.75"	38.75"

NOTE: ALL FITTING DIMENSIONS ARE FOR REFERENCE ONLY.

File Name:	SK180 ELBOW	<b>LANE ENTERPRISES, INC.</b>  SK180 MANIFOLD 90° ELBOW
Page Number:	1 OF 1	
Date Drawn:	3/10/15	
Drawn By:	JDS	

