



STORMWATER CHAMBER SPECIFICATIONS

1. STORMWATER CHAMBERS SHALL BE LANE STORMKEEPER® SK290 OR APPROVED EQUAL.
2. CHAMBERS SHALL BE MANUFACTURED FROM VIRGIN POLYPROPYLENE RESINS.
3. CHAMBERS SHALL PROVIDE CONTINUOUS , UNRESTRICTED INTERNAL SPACE WITH NO INTERNAL SUPPORT PANELS THAT WOULD IMPEDE FLOW OR LIMIT ACCESS FOR INSPECTION.
4. THE STRUCTURAL DESIGN OF THE CHAMBERS, THE STRUCTURAL BACKFILL, AND THE INSTALLATION REQUIREMENTS SHALL ENSURE THAT THE LOAD FACTORS SPECIFIED IN THE AASTHO LRFD BRIDGE DESIGN SPECIFICATIONS, SECTION 12.12 ARE MET FOR A) LONG DURATION DEAD LOADS, AND B) SHORT DURATION LIVE LOADS, BASED ON THE AASHTO DESIGN TRUCK WITH CONSIDERATION FOR IMPACT AND MULTIPLE VEHICLE PRESENCE.
5. CHAMBERS SHALL MEET ASTM F2418, "STANDARD SPECIFICATION FOR POLYPROPYLENE (PP) CORRUGATED WALL STORMWATER COLLECTION CHAMBERS."
6. CHAMBERS SHALL BE DESIGNED AND ALLOWABLE LOADS DETERMINED IN ACCORDANCE WITH ASTM F2787, "STANDARD PRACTICE FOR STRUCTURAL DESIGN OF THERMOPLASTIC CORRUGATED WALL STORMWATER COLLECTION CHAMBERS."
7. CHAMBERS AND END CAPS SHALL BE PRODUCED AT AN ISO 9001 CERTIFIED MANUFACTURING FACILITY.

IMPORTANT - NOTES FOR THE BIDDING AND INSTALLATION OF THE STORMKEEPER® SK290 SYSTEM

1. LANE STORMKEEPER® SK290 CHAMBERS SHALL NOT BE INSTALLED UNTIL THE MANUFACTURER'S REPRESENTATIVE HAS COMPLETED A PRECONSTRUCTION MEETING WITH THE INSTALLERS.
2. LANE STORMKEEPER® SK290 CHAMBERS SHALL BE INSTALLED IN ACCORDANCE WITH THE LANE STORMKEEPER® SK290 INSTALLATION GUIDELINE.
3. CHAMBERS ARE NOT TO BE BACKFILLED WITH A DOZER OR AN EXCAVATOR LOCATED OVER THE CHAMBERS. LANE RECOMMENDS THREE (3) BACKFILL METHODS:
  - A. STONESHOOTER LOCATED OFF THE CHAMBER BED.
  - B. BACKFILL AS ROWS ARE BEING BUILT WITH AN EXCAVATOR ON THE FOUNDATION STONE OR SUBGRADE.
  - C. BACKFILL FROM OUTSIDE THE EXCAVATION UTILIZING A LONG BOOM HOE OR EXCAVATOR.
4. THE FOUNDATION STONE SHALL BE LEVELED AND COMPACTED PRIOR TO PLACING CHAMBERS.
5. JOINTS BETWEEN CHAMBERS SHALL BE PROPERLY SEATED BEFORE PLACING STONE.
6. MAINTAIN MINIMUM NINE INCH (9") SPACING BETWEEN CHAMBER ROWS.
7. INLET AND OUTLET MANIFOLDS MUST BE INSERTED A MINIMUM OF 12 INCHES INTO CHAMBER END CAPS.
8. EMBEDMENT STONE SURROUNDING THE CHAMBERS MUST BE CLEAN, CRUSHED, ANGULAR STONE ¾" TO 2".
9. THE CONTRACTOR MUST REPORT ANY DISCREPANCIES WITH CHAMBER FOUNDATION SUBGRADE MATERIALS BEARING CAPACITIES TO THE SITE DESIGN ENGINEER.
10. ENSURE THAT THE SITE IS PERMANENTLY STABILIZED PRIOR TO CONNECTING THE FINAL DRAINAGE SYSTEM TO THE UNDERGROUND STORMWATER MANAGEMENT SYSTEM CONFIGURATION. THE UNDERGROUND STORMWATER MANAGEMENT SYSTEM SHALL BE KEPT FREE OF ALL CONSTRUCTION WASTE, WASH-WATER, SEDIMENT-LADEN RUNOFF AND OTHER CONSTRUCTION DEBRIS.

NOTES FOR CONSTRUCTION EQUIPMENT

1. LANE STORMKEEPER® SK290 CHAMBERS ARE TO BE INSTALLED IN ACCORDANCE WITH INSTALLATION GUIDELINES.
2. THE USE OF CONSTRUCTION EQUIPMENT OVER THE LANE STORMKEEPER CHAMBERS IS LIMITED.
  - A. NO EQUIPMENT IS ALLOWED ON BARE CHAMBERS.
  - B. NO RUBBER TIRED LOADERS, DUMP TRUCKS, OR EXCAVATORS ARE ALLOWED OVER THE CHAMBERS UNTIL PROPER FILL DEPTHS ARE ACHIEVED IN ACCORDANCE WITH THE STORMKEEPER SK290 INSTALLATION GUIDE.
  - C. WEIGHT LIMITS FOR CONSTRUCTION EQUIPMENT CAN BE FOUND IN THE STORMKEEPER SK290 INSTALLATION GUIDE.
3. A MINIMUM COVER OF 36" OF STABILIZED COVER MATERIALS OVER THE CHAMBERS IS REQUIRED FOR DUMP TRUCK TRAVEL OR DUMPING.
4. DURING NORMAL PAVING OPERATIONS, DUMP TRUCK AXLE LOADS ON 24" OF COVER FOR THE STORMKEEPER CHAMBER MAY BE NECESSARY. PRECAUTIONS SHOULD BE TAKEN TO AVOID RUTTING OF THE ROAD BASE LAYER, TO ENSURE THAT COMPACTION REQUIREMENTS HAVE BEEN MET AND THAT A MIN OF 24" OF COVER EXISTS OVER THE CHAMBERS.

USE OF A DOZER TO PUSH EMBEDMENT STONE BETWEEN THE ROWS OF CHAMBERS MAY CAUSE DAMAGE TO THE CHAMBERS AND IS NOT AN ACCEPTABLE BACKFILL METHOD. ANY CHAMBERS DAMAGED BY THE "DUMP AND PUSH" METHOD ARE NOT COVERED UNDER THE STORMKEEPER STANDARD WARRANTY.

CONTACT LANE ENTERPRISES WITH QUESTIONS ON INSTALLATION REQUIREMENTS OR CONSTRUCTION LOADING AND EQUIPMENT.

SK290 CHAMBER SYSTEM  
GENERAL NOTES & DETAILS

LANE ENTERPRISES, INC.

SCALE:	N.T.S.
DRAWN BY:	JDS
DATE:	12-13-2024
DRAWING NUMBER:	SK290

PAGE:

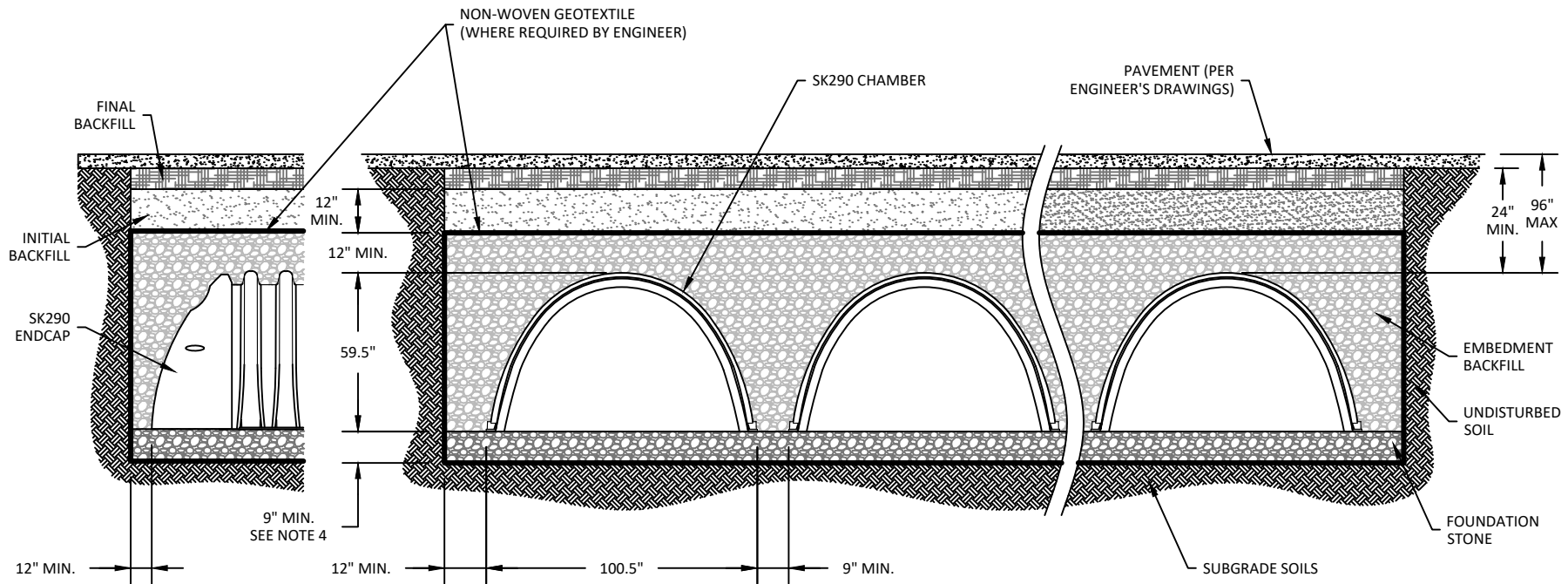

**NOTES:**

1. CHAMBER SYSTEMS SHALL BE INSTALLED IN ACCORDANCE WITH THE MANUFACTURER'S LATEST INSTALLATION GUIDELINES.
2. SUBGRADE: TRENCH BOTTOMS WITH UNSTABLE OR UNYIELDING MATERIAL SHALL BE EXCAVATED TO A DEPTH DIRECTED BY THE ENGINEER AND REPLACED WITH SUITABLE MATERIAL. FOR UNSTABLE MATERIALS, GEOTEXTILE MAY BE USED TO STABILIZE THE TRENCH BOTTOM, IF DIRECTED BY THE ENGINEER. THE DESIGN ENGINEER IS RESPONSIBLE FOR VERIFYING SUBGRADE SUITABILITY.
3. GEOTEXTILE: AN AASHTO M288 CLASS 2 NON-WOVEN GEOTEXTILE SHALL BE USED TO PREVENT ADJACENT MATERIALS FROM MIGRATING INTO THE FOUNDATION AND EMBEDMENT ZONES.
4. FOUNDATION STONE: SUITABLE MATERIAL SHALL BE A ¾ to 2 INCH, CLEAN, CRUSHED, ANGULAR STONE (AASHTO M43 SIZES NO. 3 OR 4). MINIMUM FOUNDATION STONE THICKNESS SHALL BE 9 INCHES AND INCREASED AS NECESSARY PER TABLE 1. COMPACTION REQUIREMENTS ARE MET WHEN PLACED AND COMPACTED IN 9 INCH MAXIMUM LIFTS USING TWO FULL COVERAGES WITH A VIBRATORY COMPACTOR.
5. EMBEDMENT STONE: SUITABLE MATERIAL SHALL BE A ¾ to 2 INCH, CLEAN, CRUSHED, ANGULAR STONE (AASHTO M43 SIZES NO. 3 OR 4). EMBEDMENT STONE SHALL EXTEND FROM THE TOP OF THE FOUNDATION STONE TO NOT LESS THAN 12 INCHES ABOVE THE CHAMBER. NO COMPACTION IS REQUIRED WHEN STONE IS PROPERLY PLACED ON AND AROUND THE CHAMBERS (NOTE: MANIFOLD INSTALLATION WILL REQUIRE STANDARD PIPE INSTALLATION PRACTICES).
6. INITIAL BACKFILL: SUITABLE MATERIAL SHALL BE (1) A GRANULAR, WELL-GRADED, SOIL-AGGREGATE MIXTURE WITH LESS THAN 35% FINES PER AASHTO M145, OR (2) A CLEAN, CRUSHED, ANGULAR STONE WITH AASHTO M43 SIZES NO. 3, 357, 4, 467, 5, 56, 57, 6, 67, 68, 7, 78, 8, 89, 9, OR 10. NOTE THAT PAVEMENT SUBBASE MAY COMPRISE A PORTION OF THIS LAYER. COMPACT CLEAN MATERIALS (LESS THAN 5% FINES) IN MAXIMUM 12 INCH LIFTS TO A MINIMUM 95% RELATIVE COMPACTION AND ALL OTHER MATERIALS IN MAXIMUM 6 INCH LIFTS TO A MINIMUM 95% STANDARD PROCTOR DENSITY UNLESS DIRECTED DIFFERENTLY BY THE ENGINEER. INITIAL BACKFILL SHALL EXTEND FROM TOP OF EMBEDMENT STONE TO NOT LESS THAN 24 INCHES ABOVE THE CHAMBER.
7. FINAL BACKFILL: SUITABLE MATERIALS, COMPACTION LIFTS, AND COMPACTION LEVELS AS DIRECTED BY THE ENGINEER. FINAL BACKFILL SHALL EXTEND FROM THE TOP OF THE INITIAL BACKFILL AND CONSTRUCTED TO A HEIGHT IN WHICH THE FINAL GRADE IS NO MORE THAN 96 INCHES ABOVE THE CHAMBER.
8. MINIMUM COVER: A MINIMUM COVER OF 24 INCHES IS REQUIRED TO SUPPORT A PAVING OPERATION WHEN THE SUBBASE AND BASE COURSES HAVE BEEN CONSTRUCTED TO ROADWAY STANDARDS. CONSIDERATIONS SHALL BE MADE TO INCREASE THE MINIMUM COVER TO OFFSET RUTTING POTENTIALS WHEN THE SURFACE IS LEFT UNPAVED AND LIABLE FOR TRAFFIC AND/OR CONSTRUCTION LOADINGS. SEE ALSO PAGE 1 "NOTES FOR CONSTRUCTION EQUIPMENT."
9. LOAD RATING: A PAVEMENT CONSTRUCTED ON PROPERLY PREPARED SUBBASE AND BASE COURSES WILL SUPPORT STANDARD HIGHWAY DESIGN TRUCKS (I.E. HS-20, HS-25, HL-93).

**SK290 CHAMBER SYSTEM  
GENERAL NOTES & DETAILS**

**LANE ENTERPRISES, INC.**

SCALE:	N.T.S.
DRAWN BY:	JDS
DATE:	12-13-2024
DRAWING NUMBER:	SK290

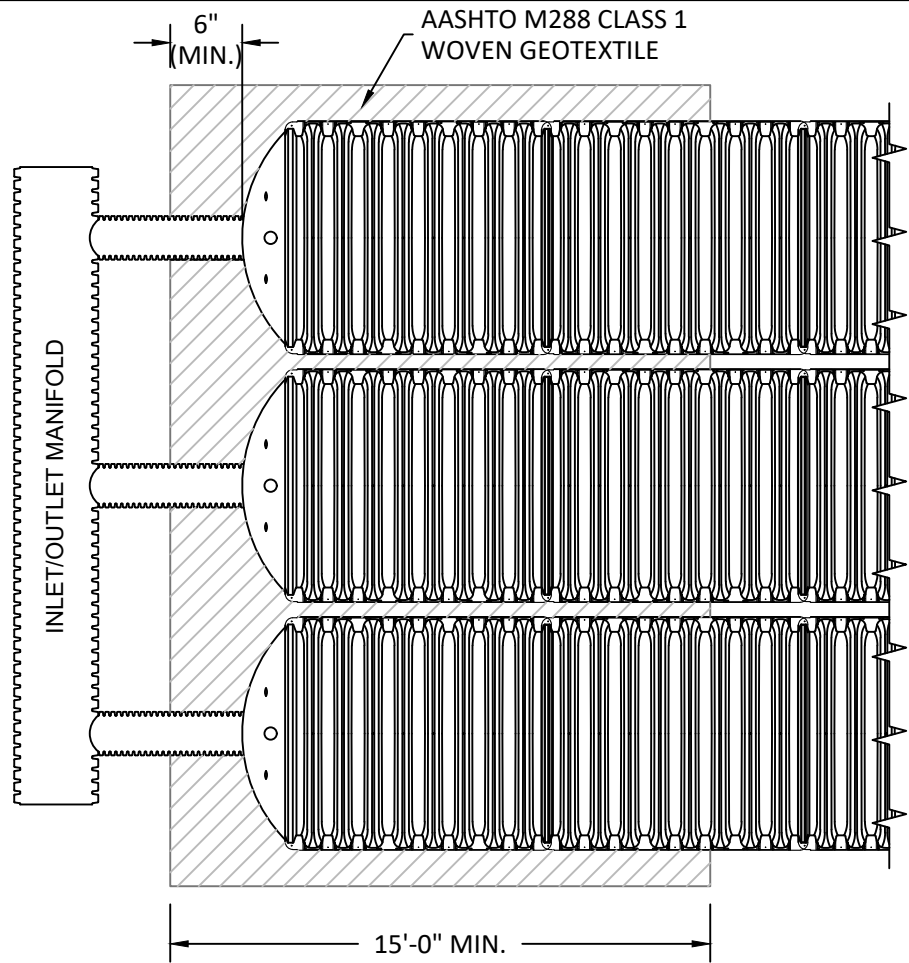

PLAN

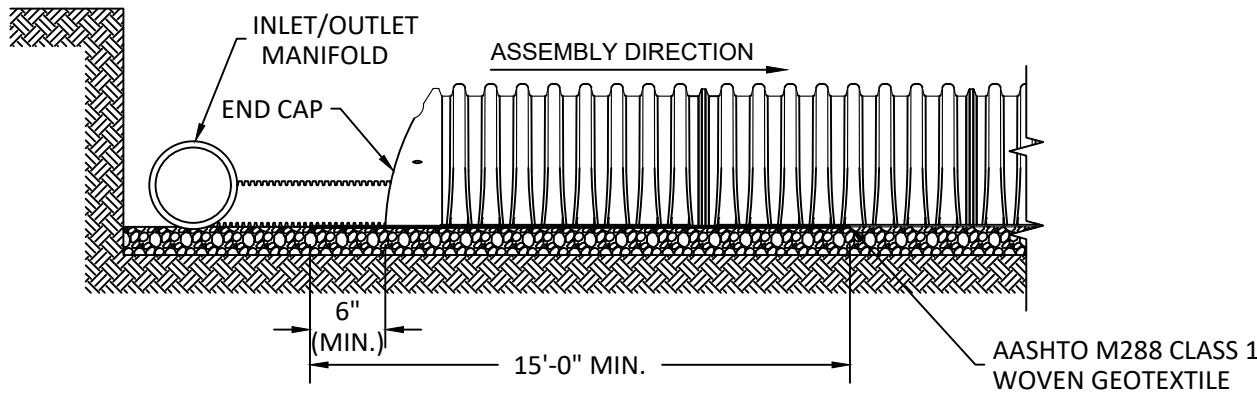

PROFILE

SCOUR PROTECTION DETAIL



SK290 CHAMBER SYSTEM  
GENERAL NOTES & DETAILS

LANE ENTERPRISES, INC.

SCALE:	N.T.S.
DRAWN BY:	JDS
DATE:	12-13-2024
DRAWING NUMBER:	SK290

PAGE:

**SEDIMENT STRIP INSPECTION AND MAINTENANCE**

**GENERAL NOTES:**

1. INSPECT EVERY 6 MONTHS DURING THE FIRST YEAR OF OPERATION. ADJUST INSPECTION SCHEDULE INTERVAL BASED ON PREVIOUS OBSERVATIONS OF ACCUMULATED SEDIMENT OR HIGH WATER ELEVATIONS.
2. CONDUCT JETTING AND VACTORING ANNUALLY OR WHEN INSPECTION SHOWS THAT MAINTENANCE IS REQUIRED.

**INSPECTION STEPS:**

1. INSPECT SEDIMENT STRIP FOR SEDIMENT

A. USING INSPECTION PORT

- I. REMOVE LID ON INLINE BASIN
- II. USING A FLASHLIGHT AND STADIA ROD, MEASURE THE DEPTH OF SEDIMENT AND RECORD ON A MAINTENANCE LOG.
- III. LOWER A CAMERA INTO THE SEDIMENT STRIP FOR VISUAL INSPECTION OF SEDIMENT LEVELS (OPTIONAL).
- IV. IF SEDIMENT IS AT OR ABOVE 3" PROCEED TO STEP 2 BELOW. IF NOT, PROCEED TO STEP 3.

B. USING UPSTREAM STRUCTURES

- I. REMOVE COVER FROM STRUCTURE AT UPSTREAM END OF SEDIMENT STRIP.
- II. USING A FLASHLIGHT, INSPECT DOWN THE SEDIMENT STRIP THROUGH THE OUTLET PIPE.
- III. MIRRORS ON POLES OR CAMERAS MAY BE USED TO AVOID A CONFINED SPACE ENTRY.
- IV. FOLLOW OSHA REGULATIONS FOR CONFINED SPACE ENTRY IF ENTERING A MANHOLE.
- V. IF SEDIMENT IS AT OR ABOVE 3" PROCEED TO STEP 2 BELOW. IF NOT, PROCEED TO STEP 3.

2. CLEAN OUT SEDIMENT STRIP USING TRUCKS FURNISHED WITH WATER JETTING AND VACUUM EQUIPMENT.

- A. FIXED CULVERT CLEANING NOZZLE WITH REAR FACING SPREAD OF 48" OR MORE IS PREFERRED.
- B. REMOVE MANHOLE LID/GRATE TO ACCESS MANHOLE CAVITY
- C. LOWER THE HOSE AND NOZZLE INTO THE STRUCTURE AND SEDIMENT STRIP INLET STUB ABOVE THE MANHOLE SUMP.
- D. THE VACUUM HOSE MAY BE POSITIONED IN THE MANHOLE SUMP AS THE JETTING ACTION PROPELS THE NOZZLE INTO AND UP THE SEDIMENT STRIP.
- E. ONCE THE NOZZLE REACHES THE END OF THE SEDIMENT STRIP, PULL BACK ACCUMULATED MATERIAL TOWARDS THE MANHOLE WITH THE JETTING ACTION WHILE THE NOZZLE IS REELED BACK TOWARDS THE MANHOLE.
- F. WHILE MATERIAL IS BEING PULLED BACK, THE VACUUM ACTION IS REMOVING MATERIAL FROM THE SUMP.
- G. REPEAT THE PROCESS UNTIL A CLEAR EFFLUENT IS OBSERVED.
- H. VACUUM STRUCTURE SUMP AS REQUIRED.

3. REPLACE ALL COVERS, GRATES, FILTERS, LIDS, ETC.

4. RECORD OBSERVATIONS AND ACTIONS.

5. INSPECT AND CLEAN BASINS AND MANHOLES UPSTREAM OF THE STORMKEEPER SYSTEM.

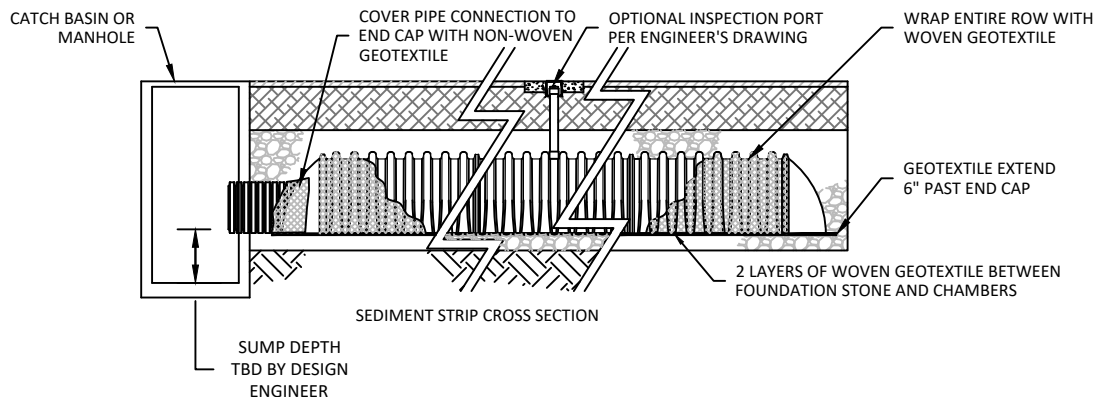
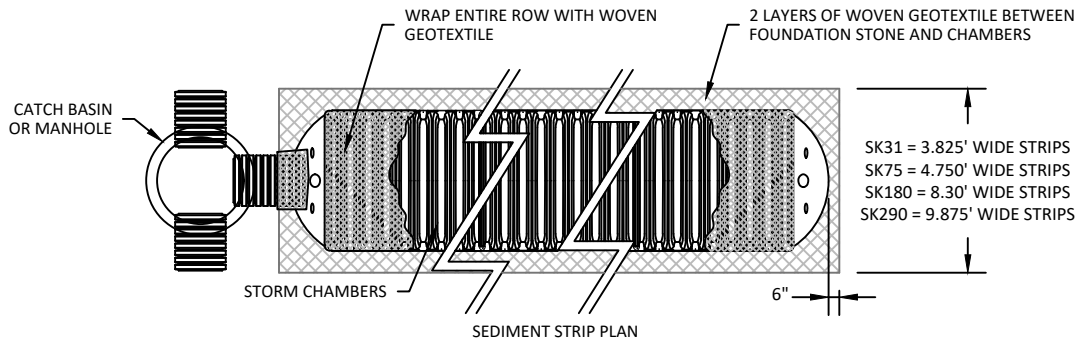

NOTE: ALL FITTING DIMENSIONS ARE FOR REFERENCE ONLY.  
ALL WOVEN GEOTEXTILE TO BE AASHTO M288 CLASS I.

SK290 CHAMBER SYSTEM  
GENERAL NOTES & DETAILS

LANE ENTERPRISES, INC.

SCALE: N.T.S.

DRAWN BY: JDS

DATE: 12-13-2024

DRAWING NUMBER: SK290

PAGE:



**TABLE 1: SK290 FOUNDATION STONE DEPTH REQUIREMENTS (INCHES)**

Cover Height ft	SK290 Minimum Required Bearing Capacity of Native Soil Subgrade, ksf																					
	4.1	4.0	3.9	3.8	3.7	3.6	3.5	3.4	3.3	3.2	3.1	3.0	2.9	2.8	2.7	2.6	2.5	2.4	2.3	2.2	2.1	2.0
2.0	9.0	9.0	9.0	9.0	9.0	9.0	9.0	9.0	9.0	9.0	9.0	9.0	9.0	9.0	9.0	12.0	12.0	12.0	15.0	15.0	15.0	
2.5	9.0	9.0	9.0	9.0	9.0	9.0	9.0	9.0	9.0	9.0	9.0	9.0	9.0	9.0	12.0	12.0	12.0	12.0	15.0	15.0	15.0	18.0
3.0	9.0	9.0	9.0	9.0	9.0	9.0	9.0	9.0	9.0	9.0	9.0	9.0	9.0	12.0	12.0	12.0	15.0	15.0	15.0	18.0	18.0	18.0
3.5	9.0	9.0	9.0	9.0	9.0	9.0	9.0	9.0	9.0	9.0	12.0	12.0	12.0	12.0	15.0	15.0	15.0	18.0	18.0	24.0	24.0	24.0
4.0	9.0	9.0	9.0	9.0	9.0	9.0	9.0	9.0	12.0	12.0	12.0	12.0	15.0	15.0	15.0	15.0	18.0	18.0	24.0	24.0	24.0	24.0
4.5	9.0	9.0	9.0	9.0	9.0	9.0	9.0	12.0	12.0	12.0	12.0	15.0	15.0	15.0	18.0	18.0	18.0	24.0	24.0	24.0	24.0	30.0
5.0	9.0	9.0	9.0	9.0	9.0	12.0	12.0	12.0	12.0	15.0	15.0	15.0	15.0	18.0	18.0	18.0	24.0	24.0	24.0	24.0	24.0	30.0
5.5	9.0	9.0	9.0	9.0	12.0	12.0	12.0	12.0	15.0	15.0	15.0	18.0	18.0	18.0	24.0	24.0	24.0	24.0	24.0	30.0	30.0	30.0
6.0	9.0	9.0	9.0	12.0	12.0	12.0	12.0	15.0	15.0	15.0	15.0	18.0	18.0	18.0	24.0	24.0	24.0	24.0	30.0	30.0	30.0	30.0
6.5	9.0	9.0	12.0	12.0	12.0	12.0	12.0	15.0	15.0	15.0	15.0	18.0	18.0	18.0	24.0	24.0	24.0	24.0	30.0	30.0	30.0	30.0
7.0	9.0	12.0	12.0	12.0	12.0	12.0	15.0	15.0	15.0	18.0	18.0	18.0	24.0	24.0	24.0	24.0	30.0	30.0	30.0	30.0	30.0	36.0
7.5	12.0	12.0	12.0	12.0	15.0	15.0	15.0	15.0	18.0	18.0	18.0	18.0	24.0	24.0	24.0	24.0	30.0	30.0	30.0	30.0	36.0	36.0
8.0	12.0	12.0	12.0	15.0	15.0	15.0	15.0	18.0	18.0	18.0	18.0	24.0	24.0	24.0	24.0	30.0	30.0	30.0	36.0	36.0	36.0	36.0

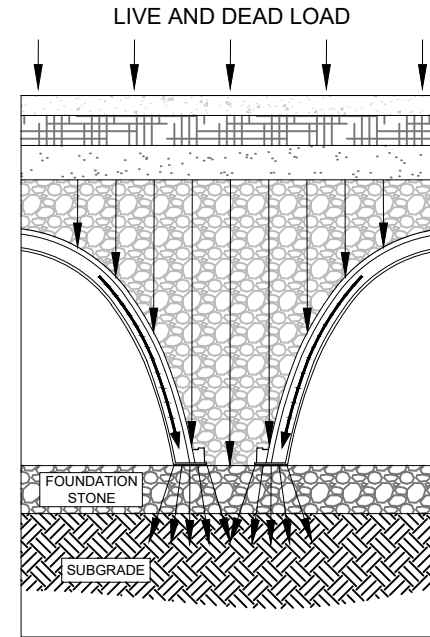

SK290 CHAMBER SYSTEM  
GENERAL NOTES & DETAILS

LANE ENTERPRISES, INC.

FOR APPROVAL ONLY  
SIGNATURE: \_\_\_\_\_  
DATE: \_\_\_\_\_  
NOT FOR CONSTRUCTION

REVISIONS			
NO	BY	DATE	NOTES

SCALE: N.T.S.  
DRAWN BY: JDS  
DATE: 12-13-2024  
DRAWING NUMBER: SK290  
PAGE: 5 OF 7

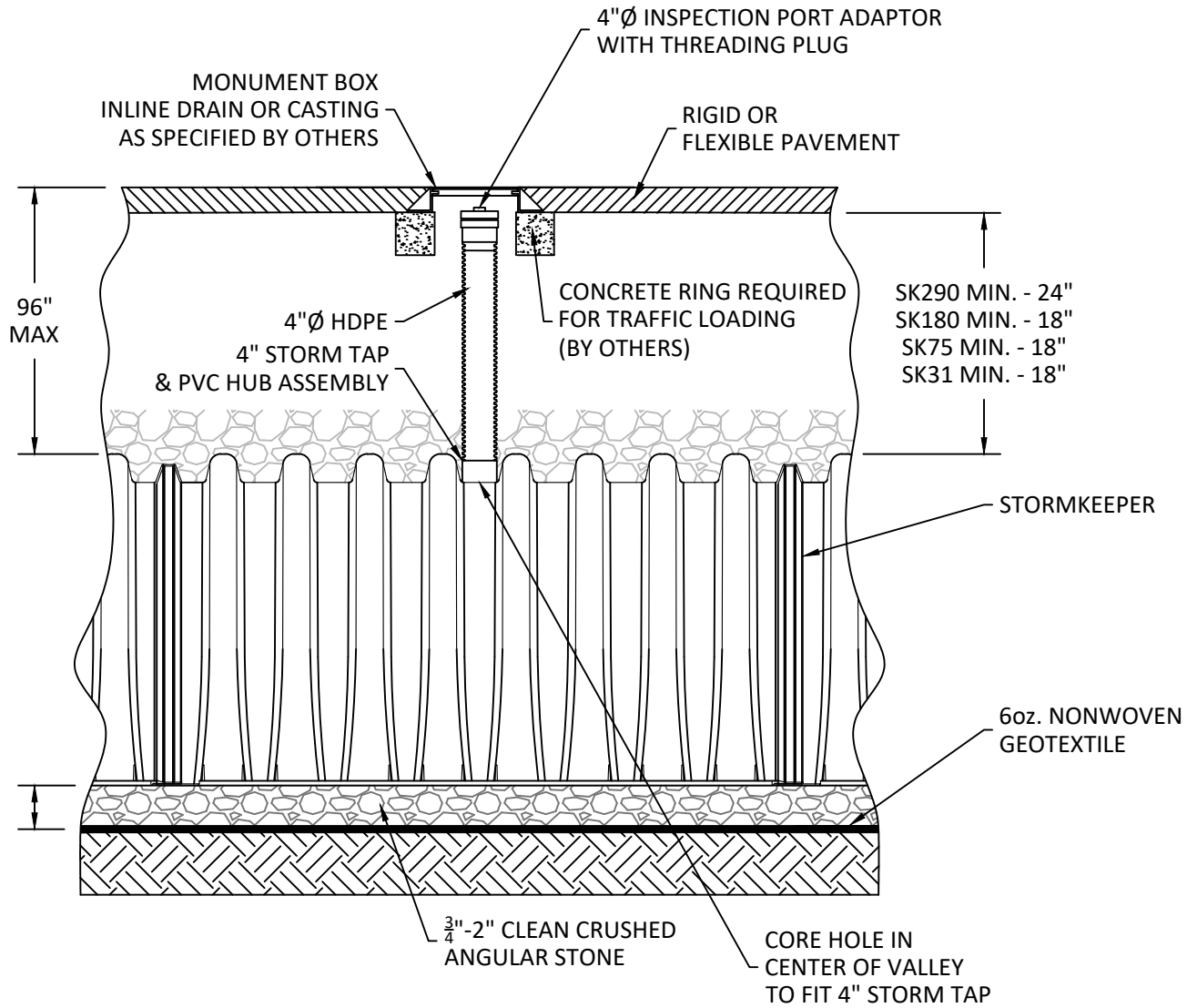

TYP. 4"Ø INSPECTION PORT

SK290 CHAMBER SYSTEM  
GENERAL NOTES & DETAILS

LANE ENTERPRISES, INC.

SCALE:	N.T.S.
DRAWN BY:	JDS
DATE:	12-13-2024
DRAWING NUMBER:	SK290

PAGE:

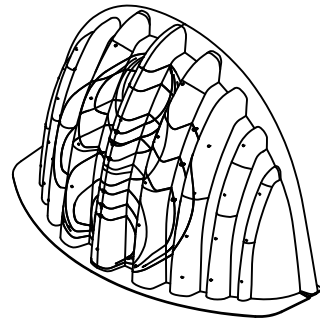
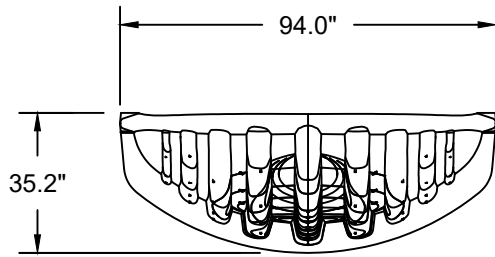

StormKeeper SK290 End Caps	
Nominal Dimensions	
Size (L x W x H)	35.2" x 94" x 59.4"
End Cap Storage	39.6 cf
Min Installed Storage	109.5 cf
Weight	82 lbs

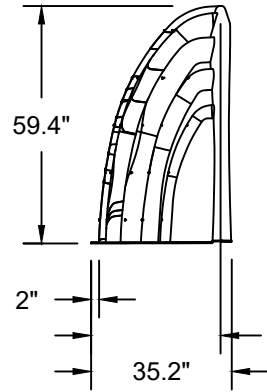
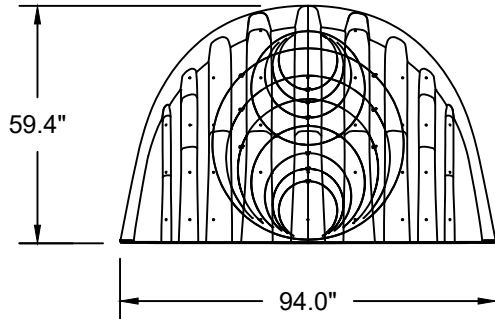

StormKeeper SK290 Chamber	
Nominal Dimensions	
Size (L x W x H)	52.8" x 100.5" x 59.5"
Chamber Storage	109.7 cf
Min Installed Storage	163.9 cf
Weight	125 lbs

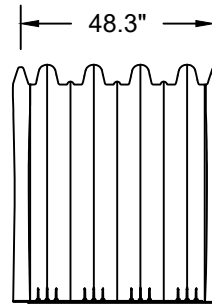
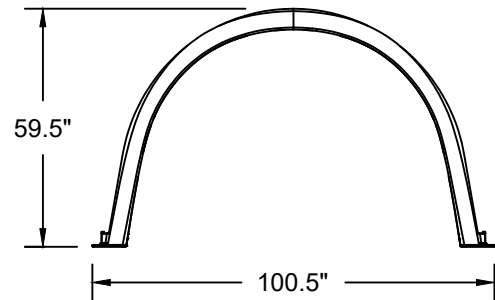

SK290 CHAMBER SYSTEM  
GENERAL NOTES & DETAILS

LANE ENTERPRISES, INC.

SCALE:	N.T.S.
DRAWN BY:	JDS
DATE:	12-13-2024
DRAWING NUMBER:	SK290

PAGE: