

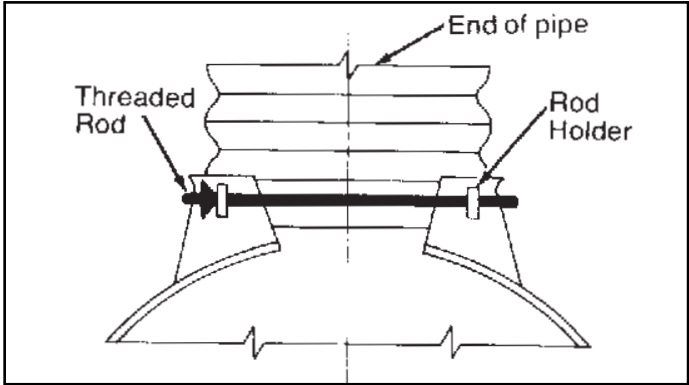

END SECTIONS FOR CMP

Technical Guide

END SECTIONS



TYPE 1 CONNECTIONS for 12" thru 24", 7" x 13" thru 28" x 20"

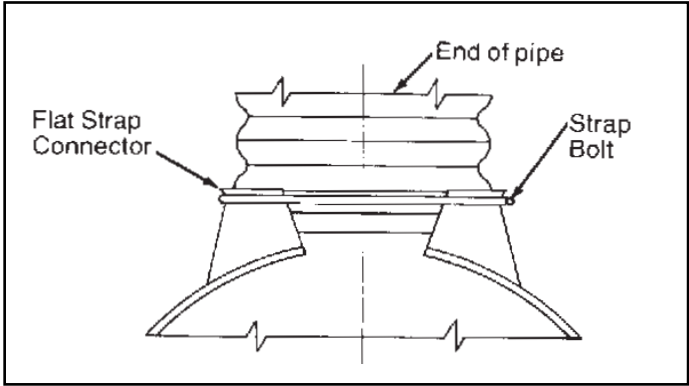

TYPE 2 CONNECTIONS for 30" & Larger for 35" x 24" & Larger

Made from galvanized steel, Lane Metal End Sections are simple to install. No special tools or equipment are required, just the basic tools used for installing metal pipe. The end sections can be easily joined to culvert barrels, forming a continuous, convenient one-piece structure. Lane's toe plates prevent undercutting and are punched to accept optional 8" toe plate extensions. End sections are supplied with either galvanized connecting straps (Type 1) or silo lugs and rods (Type 2).

Dia.	Gauge	Weight	A	B	H	L	W	Slope
12"	16	27	6	6	6	21	24	2 1/2
15"	16	37	7	8	6	26	30	2 1/2
18"	16	49	8	10	6	31	36	2 1/2
21"	16	55	9	12	6	36	42	2 1/2
24"	16	74	10	13	6	41	48	2 1/2
30"	14	128	12	16	8	51	60	2 1/2
36"	14	184	14	19	9	60	72	2 1/2
42"	12	320	16	22	11	69	84	2 1/2
48"	12	375	18	27	12	78	90	2 1/4
54"	12	440	18	30	12	84	102	2 1/4
60"	12/10	610	18	33	12	87	114	2
66"	12/10	697	18	36	12	87	120	2
72"	12/10	720	18	39	12	87	126	2
78"	12/10	810	18	42	12	87	132	1 1/2
84"	12/10	850	18	45	12	87	138	1 1/2
90"	12/10	910	24	37	12	87	144	1 1/2
96"	12/10	985	25	35	12	87	150	1 1/2



END SECTIONS

Span & Rise	Round Equivalent	Gauge	Weight	A	B	H	L	W	Slope
17x13	15"	16	28	7	9	6	19	30	2 1/2
21x15	18"	16	36	7	10	6	23	36	2 1/2
24x18	21"	16	43	8	12	6	28	42	2 1/2
28x20	24"	16	55	9	14	6	32	48	2 1/2
35x24	30"	14	95	10	16	8	39	60	2 1/2
42x29	36"	14	140	12	18	9	46	75	2 1/2
49x33	42"	12	233	13	21	9	53	85	2 1/2
57x38	48"	12	315	18	26	12	63	90	2 1/2
53x41	48"	12	330	18	25	12	63	90	2 1/2
64x43	54"	12	357	18	30	12	70	102	2
60x46	54"	12	375	18	34	12	70	102	2
71x47	60"	12/10	480	18	33	12	77	114	1 1/2
66x51	60"	12/10	487	18	33	12	77	116	1 1/2
77x52	66"	12/10	616	18	36	12	77	126	1 1/2
73x55	66"	12/10	625	18	36	12	77	126	1 1/2
83x57	72"	12/10	670	18	39	12	77	138	1 1/2
81x59	72"	12/10	680	18	39	12	77	138	1 1/2
87x63	78"	12/10	729	22	38	12	77	148	1 1/2
95x67	84"	12/10	755	22	34	12	77	162	1 1/2
103x71	90"	12/10	810	22	38	12	77	174	1 1/2
112x75	96"	12/10	907	24	40	12	77	174	1 1/2

All dimensions in inches plus or minus standard shop tolerances; weight is in pounds.

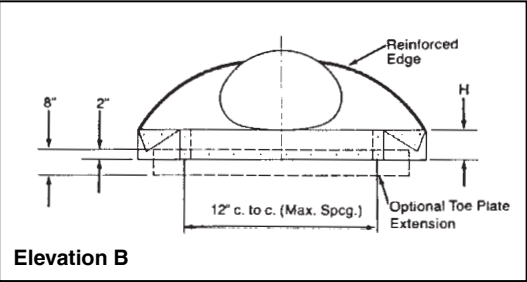
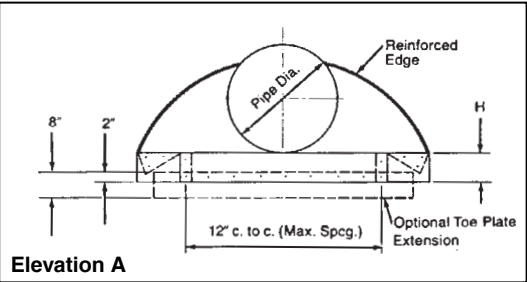
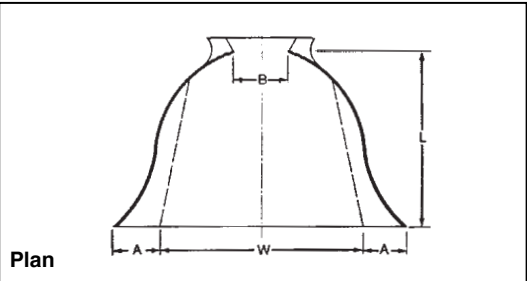

Notes:

- For 60" and larger diameter pipe end sections, reinforced edges to be supplemented with hot dipped galvanized stiffener angles.
- For 77" x 52" and larger pipe arch end sections, reinforced edges and center panel seams to be supplemented by hot dipped galvanized stiffener angles.
- Multiple panel end sections have lap seams tightly joined by rivets or bolts.
- Corner plate and toe plate to be same gauge as end section.
- Fill slope need not match end section slope. Fill can be shaped to fit.
- End sections are manufactured to AASHTO and most state requirements.

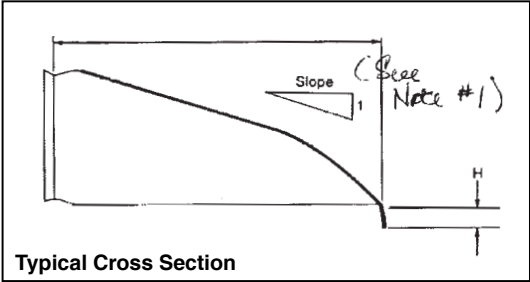



LANE Enterprises, Inc.

3905 Hartzdale Drive, Suite 514

Camp Hill, PA 17011

P: 717.761.8175 • F: 717.761.5055

lane-enterprises.com

LANE Facilities

PENNSYLVANIA

Bedford 814.623.1191

Carlisle 717.249.8342

King of Prussia 610.272.4531

Pulaski 724.652.7747

Shippensburg 717.532.5959

VIRGINIA

Bealeton 540.439.3201

Dublin 540.674.4645

Wytheville 276.223.1051

NEW YORK

Ballston Spa 518.885.4385

Bath 607.776.3366

NORTH CAROLINA

Statesville 704.872.2471

Lane provides a complete range of drainage solutions for every application.

LANE Products

Corrugated Metal Pipe

Spiral Rib Pipe

Corrugated HDPE Pipe

Structural Plate Pipe

Low Profile Box Culvert

Open Top Slotted Drain

Stormwater Management Systems

CFT (HDPE) Water Quality Unit

CMP Sandfilter

Custom Fabrications

Welded Wire Mesh Gabions

Structural Plate Headwalls

LongSpan Bridge & Culvert Services

Rebar and Custom Powder Coatings



ncspa.org



plasticpipe.org

