

Lane's 8" Reverse Q Pond Outlet has the capacity to drain as much as 126,000 cubic feet of water per day.

Sizing the Lane Reverse Q

There are eight (8) standard sizes of the Reverse Q Pond Outlet. In addition, the RQ orifice plate, which is located in the throat of the outlet lever arm, is designed to set the exact discharge rate required. For example, a 6" model with a 5.05" orifice will discharge an average of 47,000 ft³/day, while the same model with a 5.95" orifice will discharge 66,000 ft³/day.

Engineers and designers can access sizing calculators at lane-enterprises.com that allows them to experiment with different maximum discharge rates and drawdown duration times. A hydrograph is produced for each solution, showing the volumes being released over the whole drawdown period. This permits the designer to balance discharge and drawdown time to suit local requirements and achieve site storm water goals.

Improving water quality from construction sites and delaying the rate of discharge to reduce downstream peak flows is now possible when designers specify the Lane Reverse Q Pond Outlet.

Reverse Q Discharge Chart				
Size	Min Depth	Max Depth	Min Q/Day	Max Q/Day
1.5"	2"	8"	0	2,883
2"	2"	8"	2,884	5,277
2.5"	2"	8"	5,278	8,061
3"	2.5"	10"	8,062	13,610
4"	3"	12"	13,611	26,737
5"	3.5"	14"	26,738	43,900
6"	4"	16"	43,901	66,298
8"	5"	20"	66,299	126,289

Access the Reverse Q Pond calculators:
lane-enterprises.com/Reverse-Q-Pond-Outlet

Patent # US 9,574,337 B1.

About Lane

As a full-line manufacturer of corrugated metal and plastic drainage products, Lane Enterprises, Inc. operates plants throughout the Northeastern, Mid-Atlantic, and South-Central states producing various types of buried structures for the construction industry.

For nearly 90 years, Lane has partnered with contractors, engineers, and municipalities to supply reliable products that provide the highest levels of service life, strength, versatility, and economy. Our focus on quality products, responsive customer service, and technical expertise has established a long, proven history of successful partnerships within the industries we serve.



Lane Enterprises, Inc.
Corporate Headquarters
3905 Harzdale Drive, Suite 514 • Camp Hill, PA 17011
P: 717-761-8175 • F: 717-761-5055
lane-enterprises.com

© 2020 Lane Enterprises
BAKZID-5/20-AA



THE REVERSE Q POND OUTLET
HELPING TO PROTECT THE QUALITY OF OUR WATERWAYS

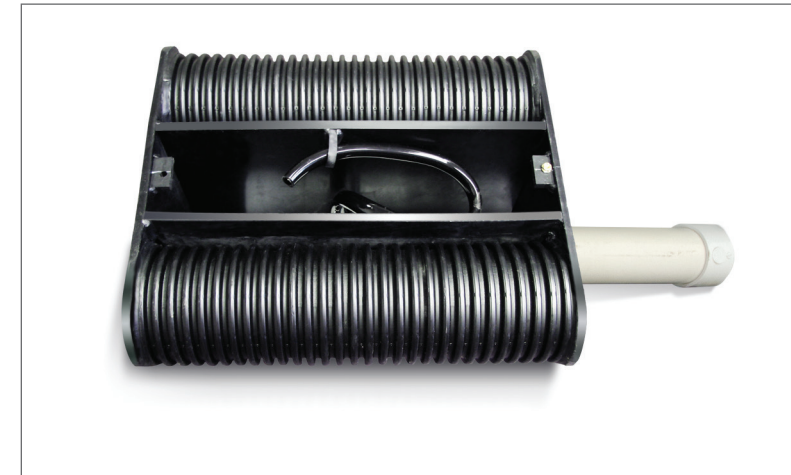

Making Advances in Water Quality

While there have been tremendous strides in the area of water quality over the last 40 years, we still have important – and achievable – goals remaining. Sediment and fine soil particles from exposed soil surfaces at construction sites contribute significantly to the pollution load in storm water. Today, regulations and best management practices are used to address velocity, the quantity and duration of storm water runoff in order to effectively improve water quality.

"Polluted storm water runoff is a leading cause of impairment to the nearly 40 percent of surveyed U.S. water bodies which do not meet water quality standards."

- Environmental Protection Agency

Introducing the Reverse Q Pond Outlet

Help protect the quality of our waterways and meet EPA Phase II goals to reduce pollutant loads with the Reverse Q Pond Outlet.

RQ Pond Outlet: The Engineer's Advantage

- Gives engineers the ability to pick a specific pond drawdown duration and peak flow that will meet the storm water goals of the project.
- Protects downstream waterways from experiencing peak flows, normally occurring early on in a storm event.
- Allows for the delaying of higher flows until later in the drawdown cycle.
- Increases average retention time without increasing total drawdown time.

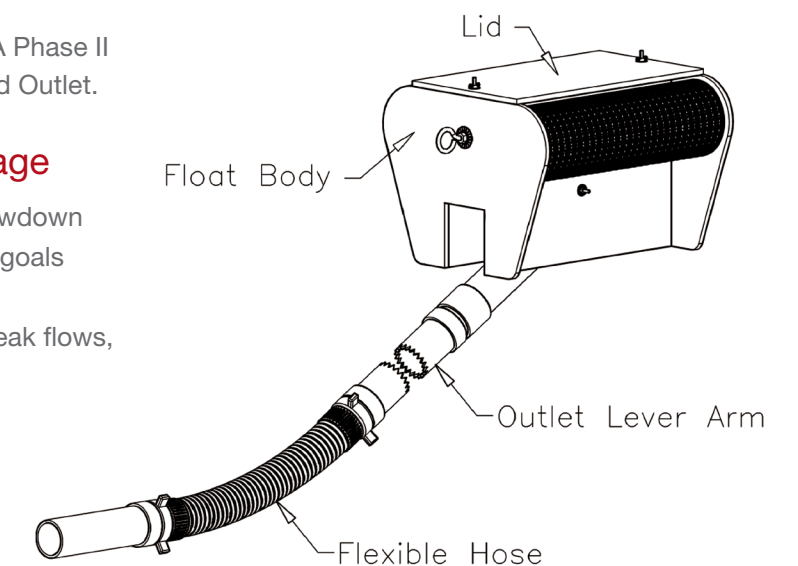

For more information on the Reverse Q Pond product, go to:
lane-enterprises.com/Reverse-Q-Pond-Outlet

Improved Performance for Sediment Basins

The Lane Reverse Q Pond Outlet provides design and municipal engineers with the opportunity to improve the performance of sediment basins by optimizing the balance between pond retention time, sediment settling, and pond discharge rates.

By reversing the shape of the outlet discharge hydrograph from the typical higher head/higher discharge pattern with a unique lever arm outlet, the Reverse Q can significantly improve the quality of the discharge from a settling pond.

REVERSING THE SHAPE OF THE OUTLET HYDROGRAPH

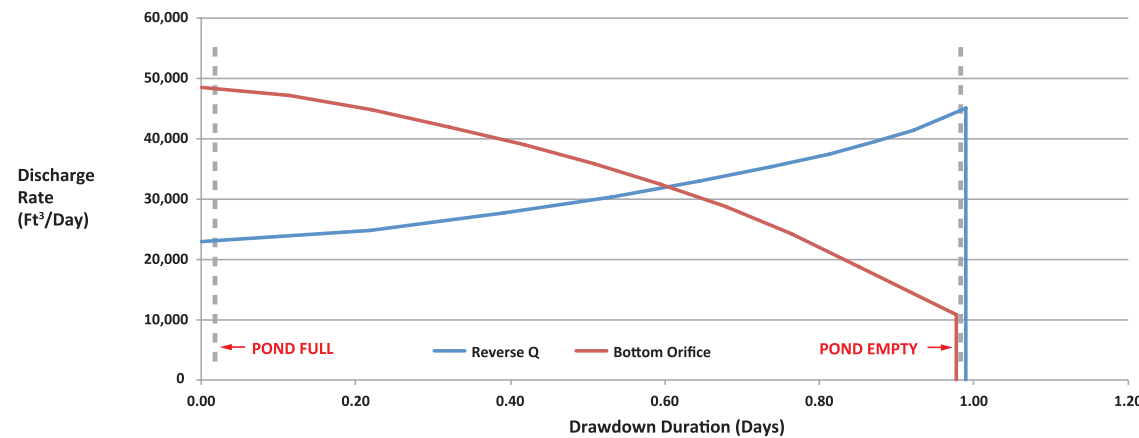

Reverse Q vs. Bottom Orifice Discharge Hydrographs (from pond full to empty)

An Old Standard

Historically, sediment basins have been designed with an outlet riser and orifice at the bottom of the riser that restricts the flow out of the basin. The discharge increases as the basin fills due to an increase in the head pressure above the orifice. Therefore, the discharge increases as the storm intensity increases to a peak discharge and then subsides as the storm subsides. The riser acts as an overflow when the capacity of the basin is reached.

THE PROBLEM

The controlled release of storm water from an orifice doesn't fully mitigate downstream flooding when multiple sites are discharging in a given watershed. Since the orifice is located at the bottom of the riser, the discharge is drawn from the area of the basin where water quality is the poorest. Rip rap and fabrics help to reduce the amount of sediment discharged, however, drawing the discharge from the top of the basin, where the water quality is better results in improved water quality.

THE SOLUTION

To achieve the highest level of water quality from a sediment basin and to reduce the cumulative effects of multiple sediment basins discharging into a watershed, sediment basins that draw from the top of the basin and vary the rate of discharge in reverse of the storm intensity perform better than traditional sediment basins.

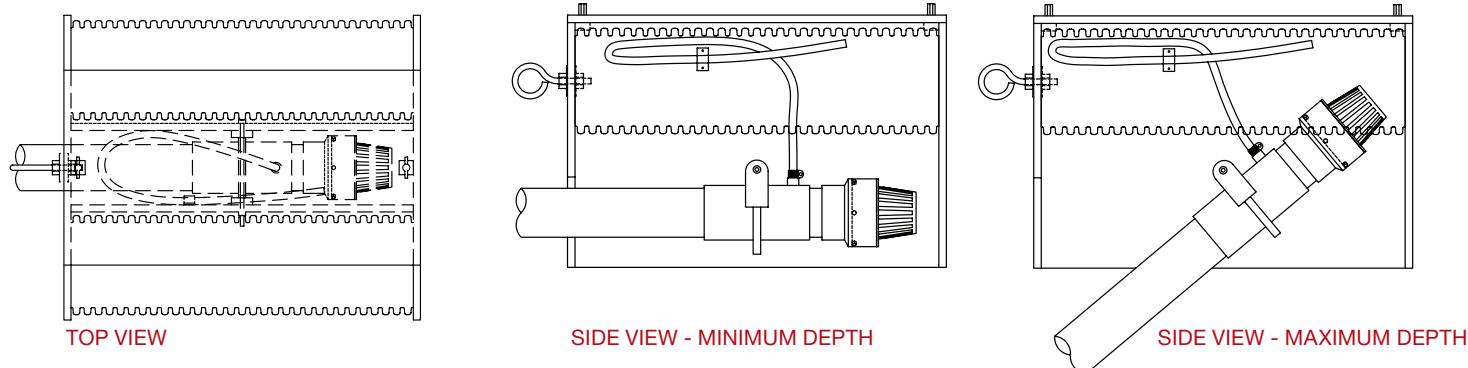

A New Innovation: The Reverse Q

Lane has significantly improved the performance of sediment basins through its innovative design - the Lane Reverse Q Pond Outlet. The Reverse Q addresses both water quality and water quantity by utilizing a floating orifice that draws discharge water from the top of the sediment pond where the water is clearest throughout the storm event.



The revolutionary aspect of the Reverse Q is the outlet lever arm which varies the head on the orifice, essentially allowing designers to customize and reverse the discharge curve when compared with traditional riser orifice design or even when compared with other floating orifices. Reversing the shape of the discharge pattern means average retention time is increased, allowing for more sediment removal. The Lane RQ allows for the delaying of maximum discharge rates until after the peak of the storm event has passed, thereby reducing potential downstream flooding.

The Lane Reverse Q gives you the ability to fool Mother Nature by allowing for lower discharge rates when downstream flooding rates are at their maximum.

Built to Perform

The Lane Reverse Q control structure is constructed from durable, weatherproof high density polyethylene (HDPE) pipe and sheet. Both are protected from UV deterioration. The connecting outlet pipe is made from a tough Schedule 40 PVC pipe and fittings. The final connection to the outlet pipe is made with a flexible hose that allows the Reverse Q to rise and fall with the pond level. Clogging of the orifice is prevented by locating the orifice within the body of the float, which extends well below the orifice when it is at maximum depth. The top of the pipe floats are protected by a removable cover or optional expanded aluminum screen to prevent leaves and debris from entering the area between the floats. With either option, the opportunity for leaves or debris to enter the outlet orifice and clog the discharge pipe is virtually eliminated.

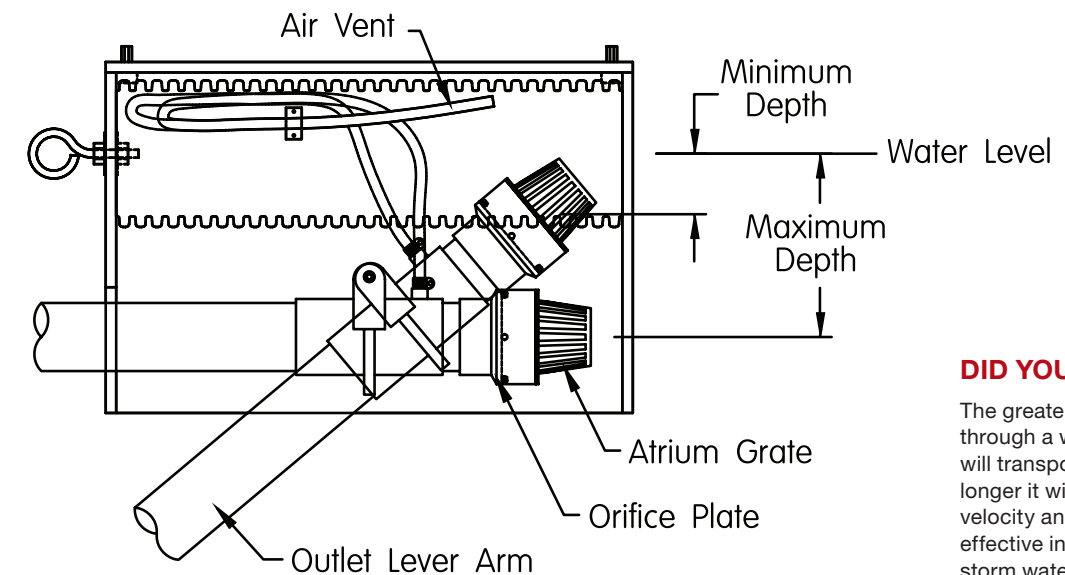

DID YOU KNOW?

The greater the quantity of water flowing through a waterway, the more sediment it will transport, and, at higher velocities, the longer it will remain suspended. Reducing velocity and delaying discharge have proven effective in reducing pollutant load from storm water.