



SK180 Chamber Installation Guideline

Prior to installation of the chamber system, adequate attention to the following guidelines is required. In addition, the chamber supplier, chamber installer (site contractor) and the design engineer may meet for a pre-construction meeting to discuss any questions relating to the installation process, and the guidelines herein.

Fill Material Location	Material Description	AASHTO M43 Designation	Compaction Requirements
[D] Final Backfill Fill material for Layer D starts at the top of the C layer to the bottom of the pavement or to the finished grade of an unpaved surface. The pavement subbase may be part of the final backfill.	Any backfill which provides adequate subgrade for the project per the engineer's plans. Plans shall indicate subgrade requirements.	N/A	Subgrade will be placed and compacted to the requirements as shown on the site plans.
[C] Initial Backfill Material for layer C starts at the top of the embedment zone (layer B) and continues to 24" above the top of the chamber. The pavement subbase may be part of the initial backfill layer.	Well graded granular material, <35% fines.	AASHTO M45 A-1, A-2, A-3 or AASHTO M43 3, 357, 4, 467, 5, 56, 57, 6, 67, 68, 7, 78, 8, 89, 9, 10	Compaction will not begin until a minimum of 24" of material is placed over the chambers. Additional layers shall be compacted in 12" lifts to a minimum of 95% standard proctor density for well graded material.
[B] Embedment Stone Embedment stone will surround the chambers and extends from the top of the bedding stone (layer A) to the bottom of the fabric layer.	3/4" to 2" clean crushed angular stone.	3, 357, 4, 467, 5, 56, 57	No compaction required.
[A] Bedding Stone Bedding Stone extends from the sub grade to the foot of the chambers.	3/4" to 2" clean crushed angular stone.	3, 357, 4, 467, 5, 56, 57	Placed in 9" lifts and compacted with a vibratory roller.

6 Construction Loading Refer to Table 2 for maximum allowable construction vehicle loads.

Material Location	Fill Depth above chambers	Max Allowable Wheels Loads		Max Allowable Track Loads		Max allowable roller loads
		Max Axle Load for Trucks	Max Wheel Load for Loaders	Track Width	Max Ground Pressure	Max Drum Weight Dynamic Force
[D] Final Fill Material	in. 36" Compacted	lbs. 32,000	lbs. 16,000	in. 12"	psf 3420	lbs. 38,000
				18"	2350	
[C] Initial Fill	24" Compacted	32,000	16,000	24"	1850	20,000
				30"	1510	
				36"	1310	
				12"	2480	
				18"	1770	
				24"	1430	
	24" Dumped	24,000	12,000	30"	1210	16,000
				36"	1070	
				12"	2245	
				18"	1625	
				24"	1325	
				30"	1135	
18"	24,000	12,000	36"	1010	5,000	
			12"	2010		
			18"	1480		
			24"	1220		
[B] Embedment Zone	12"	Not Allowed	Not Allowed	30"	1060	Not Allowed
				12"	1100	
				18"	715	
				24"	660	
6"	Not Allowed	Not Allowed	Not Allowed	30"	580	Not Allowed
				Not Allowed	Not Allowed	

1 Handling and Storage

- Upon arrival to the project site, visually inspect the chambers to ensure accurate quantities. Any damage that may have occurred during transport should also be noted at this time.
- Chambers should be stored in an area that is flat and free of debris. To avoid the potential for damage, this storage area should be isolated well away from the traveling paths used for construction vehicle traffic.
- For efficient shipping and to allow ease in handling and storage, the chambers are stacked neatly upon themselves and secured to a pallet. Unloading is best accomplished via forklift.

2 Foundation and Bedding Preparation

- Using the project plans and the appropriate details, excavate the chamber system bed in a manner to sufficiently accommodate the chambers and manifolds. To ensure an adequate fit, and to allow for a stone border, an additional 12" of excavation is required between the trench sidewalls and the chamber system.
- Upon the prepared foundation, place a 6oz non-woven fabric on the bed bottom and up and along the sidewalls. Maintain a 24" overlap of fabric at all seams.
- If standing water is present, dewatering measures should be utilized.
- Using the project plans and appropriate details, provide a level base of 3/4"-2" clean crushed angular stone over the entire trench bed bottom. Foundation stone depth as indicated on the project plans (minimum 9"). See Figure 1. Using a vibratory roller, compact the stone base to achieve a flat level surface.
- If a soft, unstable foundation is encountered, it should be over excavated and replaced with a suitable material as determined by the project engineer.
- If specified on the project plans, the perimeter underdrain piping may be laid at this point.

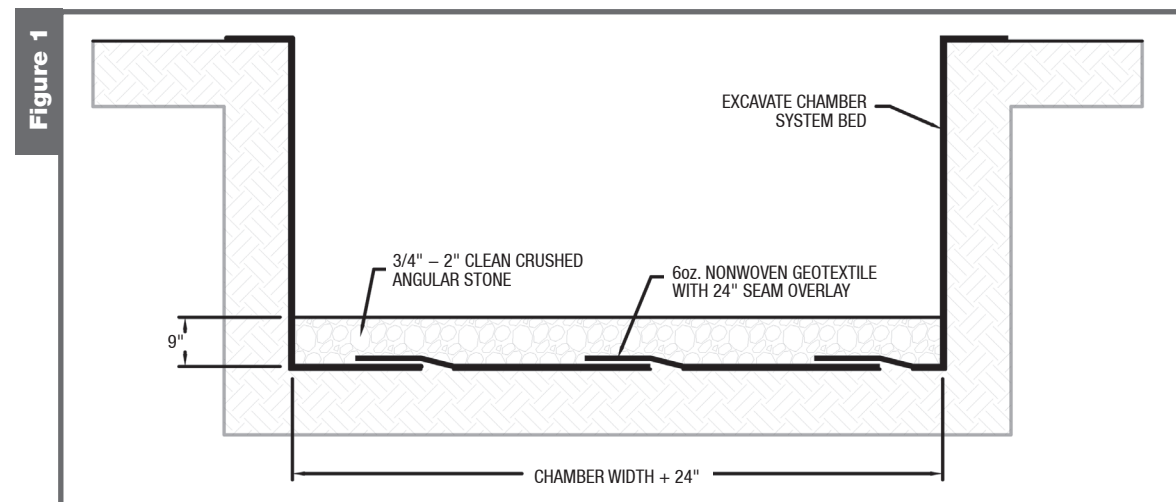

3 Manifold Assembly and Chamber Placement

- Using the project plans and appropriate details, fully assemble the manifold system.
- To alleviate the potential for scour at the inlet locations, lay a 15' wide strip of woven geotextile, along the entire length of the manifold mainline, adequately carpeting the bedding beneath the inlet locations. See Figure 2&3.
- Position the first chamber and end cap of each row with the inlet pipes. At the designated locations, core an opening in the end cap and insert the inlet pipe. The inlet pipes should penetrate 12" into the end cap. Repeat this process for each row.
- Maintaining an 8" minimum clear space between each row is required. The assembly of each row is achieved by over topping the last rib of the initial chamber with the first rib of the succeeding chamber. Overlap locations are labeled on each chamber. Row assembly should not exceed the reach of the backfill placement equipment. The final chamber of each row shall also be equipped with an end cap.
- Endcaps are placed with the endcap overlapping the top of the reduced size joining corrugation. The endcap should be held in place by screws during backfill operations.

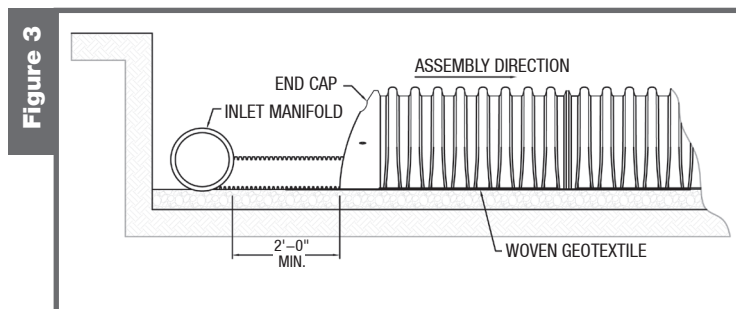
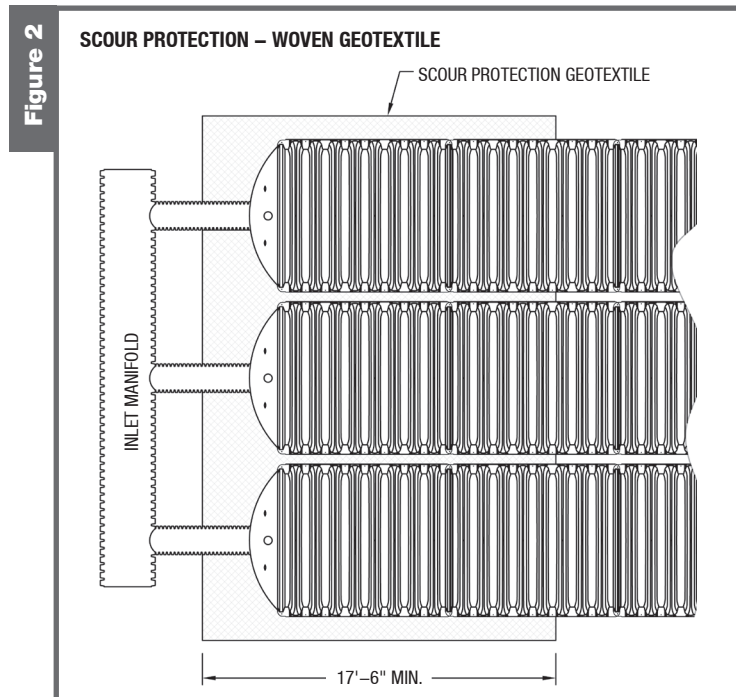

4 Inspection Port Placement

- Each chamber crown is equipped with one circular cut out point to accommodate the vertical inspection port riser. Using the project plans, identify which chambers should be fitted with inspection ports. Using a reciprocating saw, cut out the 4" diameter opening at the appropriate location. Insert a Uni-Tee or equal into the opening.
- Utilizing 4" PVC Sch. 40 pipe and fittings build the inspection port as shown in Figure 4.

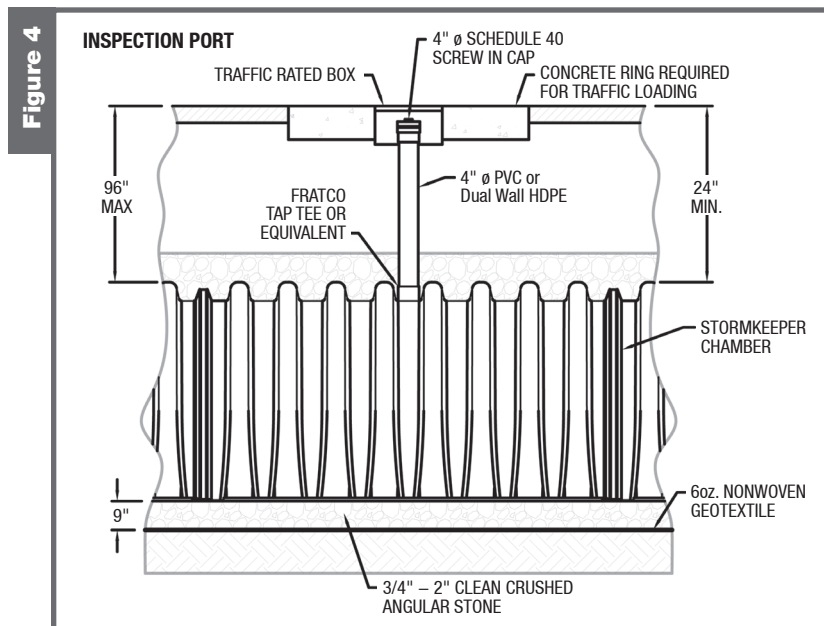

5 Chamber Backfill Process

- Backfill material used for embedment/ anchoring and for surrounding areas will be 3/4"-2" particle size, clean, crushed angular stone.
- Placement of backfill material for embedment and surrounding areas is best accomplished by using the long reach of an excavator or stone shooter/conveyor system. **No construction equipment shall be situated atop of the chamber system.**
- In order to prevent chamber shifting and to maintain row spacing, carefully deposit the stone evenly along the centerline of the chamber, allowing the stone depth between the rows to rise equally. During this phase, stone height between rows should not differ by more than 12" at any time.
- After the anchoring phase is complete, stone placement may continue to surround the chambers and around the perimeter. Stone should cover the top of the chamber crown to a minimum height of 11.5".
- Small light weight tracked dozers with ground pressure less than 1100 lbs/sf may be used at this point to finalize the grading of cover stone. Stone must be pushed parallel to rows at all times. **Wheel and Roller Loads Not Allowed.**
- Cover the entire top of the stone bed with a layer of 6oz Non-Woven fabric. Overlap all seams 24". Utilizing excavator positioned off bed, place initial backfill. Begin compaction at 24". Roller to travel parallel with rows.

Note: See Figure 5 and Table 1

Figure 5

