

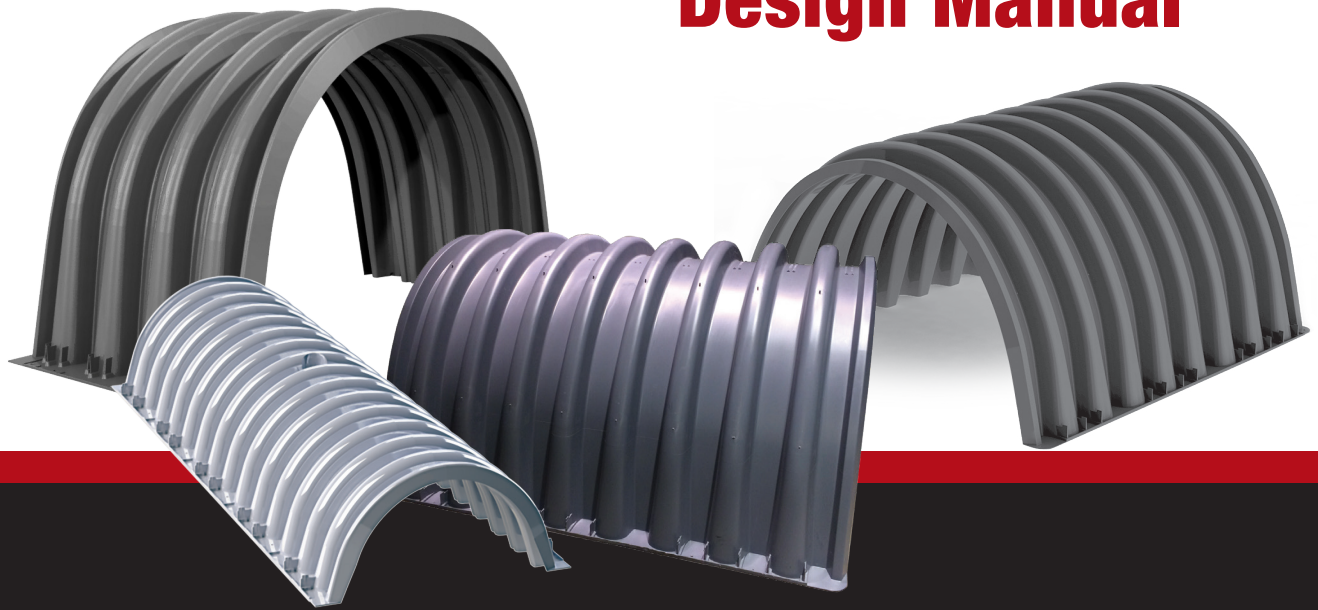

STORMKEEPER[™]
STORMWATER CHAMBER

Design Manual



StormKeeper[™] Chamber Systems
for StormWater Management

Table of Contents



1.0 Introduction	2
2.0 Product Information	3
3.0 Structural Design.....	7
4.0 Subsurface Foundation Requirements.....	8
5.0 Installed Storage Volumes for StormKeeper Chambers	10
6.0 Required Materials for Installation.....	11
7.0 Stormwater Flow Into Chambers	14
8.0 Inletting of Chambers.....	17
9.0 Other Considerations	18
10.0 System Sizing.....	19

The StormKeeper™ chamber represents the most advanced engineering, molding, and structural performance in the stormwater management industry. Lane Enterprises can assist in specifying StormKeeper stormwater systems. Our expertise includes the layout of chambers to meet volume requirements, as well as inflow and outflow from the StormKeeper chamber system. Lane can assist with conversions from other traditional stormwater management systems including pipe, above ground ponds, vaults, and other manufactured and natural systems. The design engineer is responsible for assuring that the layout meets all required design elements and is in compliance with the regulations which cover the project.

1.0 Introduction



1.1 Introduction

The StormKeeper chamber system was developed to allow for an alternative stormwater management system for design professionals that provides a more efficient means of managing stormwater runoff from developed land. The applications for the StormKeeper system include commercial, residential, industrial, highway, and agricultural drainage. StormKeeper chambers provide a lower cost solution for providing excellent stormwater management with the ability to tailor the solution to site requirements.

The StormKeeper system has been designed and manufactured to exceed the requirements of the American Society for Testing Materials (ASTM) standards. The injection molded structures provide the most cost-effective, structurally superior chambers for the underground stormwater management market.

1.2 Product Design

StormKeeper chambers are designed in accordance with Section 12.12 of the American Association of State Highway and Transportation Officials (AASHTO) Load Resistance Factor Design (LRFD) Bridge Design Specifications. They are injection molded and meet the requirements of ASTM F2418 (polypropylene chambers). In addition, StormKeeper chambers are designed in accordance with ASTM F2787. These standards dictate that the chambers be in compliance with rigorous design and quality requirements. All StormKeeper chambers are manufactured at International Organization for Standardization (ISO) 9001 compliant facilities.

1.3 Technical Support

During the design and construction of any underground stormwater management structure, it is frequently necessary to provide technical support for the product being designed and installed. Lane provides engineering support for StormKeeper chamber systems, including assistance with volume calculations and layout of the chamber system.

2.0 Product Information



2.1 Applications

StormKeeper chambers are ideal to provide storage, while maintaining above-ground uses such as parking lots, roadways, and greenspace. Although StormKeeper chambers were designed to primarily function as a stormwater detention and retention structure, they also provide excellent water quality benefits and can be used to provide both water quality and quantity management.

StormKeeper chambers provide maximum flexibility in layout and design. They can be configured in large beds or in individual trenches and can be used on almost any site to provide the required storage and improve water quality. The chambers can be retrofitted to sites that have already been developed and can be designed to efficiently and easily work around utilities, structures, and other boundaries.

2.2 Stormwater Detention

Chamber systems have been used in stormwater detention for several years. The detention system is primarily used to hold stormwater before it is released from the site. This method is used to reduce the peak flow rates of the site to pre-development or undisturbed levels. The StormKeeper stormwater chamber system is an open bottom structure placed on a stone bedding and in most cases, infiltration of stormwater into the ground is a desirable result of underground detention structures. Most chamber systems are designed to provide a detention system type of control. There are limited circumstances where infiltration may be undesirable, such as soft subgrades, karst topography, and expansive clay subgrades, to name a few. In these situations a geomembrane liner can provide an excellent alternative to limit infiltration.

2.3 Chamber Sizing

The primary determining factors when choosing a chamber size is the depth to groundwater, bedrock, other restrictive surface, available area for the underground system, the cover height required over the system, and the outlet invert restrictions.

Because of differing site restrictions, StormKeeper chambers are available in four sizes: SK31, SK75, SK180, and SK290. The SK31 has a capacity of 31 cubic feet per chamber installed, based on stone porosity of 40%. It is ideal for sites with limited vertical depths. The SK75 has a capacity of 75 cubic feet per chamber installed, based on a stone porosity of 40%. In many cases, this is the optimal installation.

For sites with more vertical room and less horizontal footprint the SK180 offers an excellent choice with 180 cubic feet of storage based on a 40% stone porosity. This is the chamber of choice for tight sites with steep natural grades.

Finally, the SK290 provides the largest storage capacity in the StormKeeper family. This chamber competes favorably with pipe diameters of 60 and 72 inches.

Illustrations of all three chambers are shown in **Figures 1, 2, 3, and 4.**

2.0 Product Information

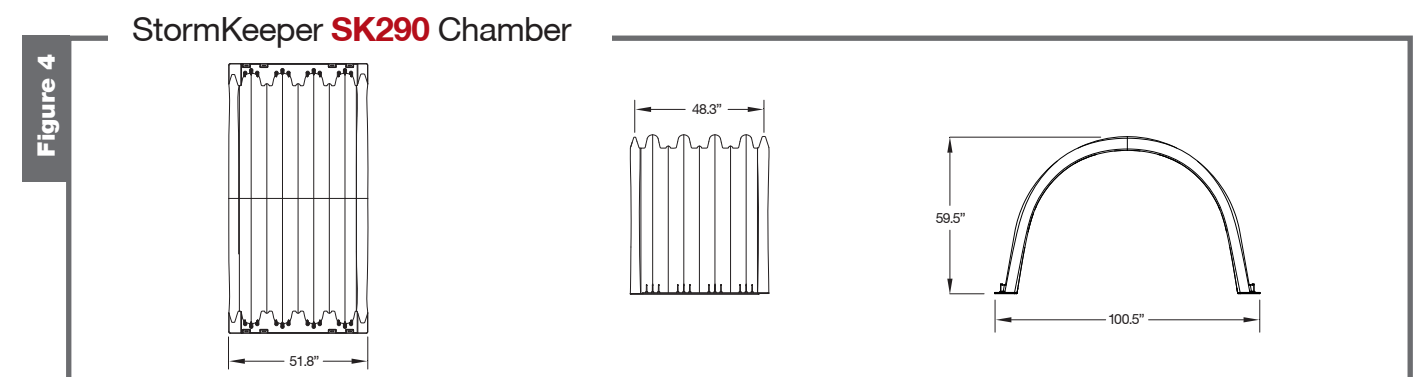
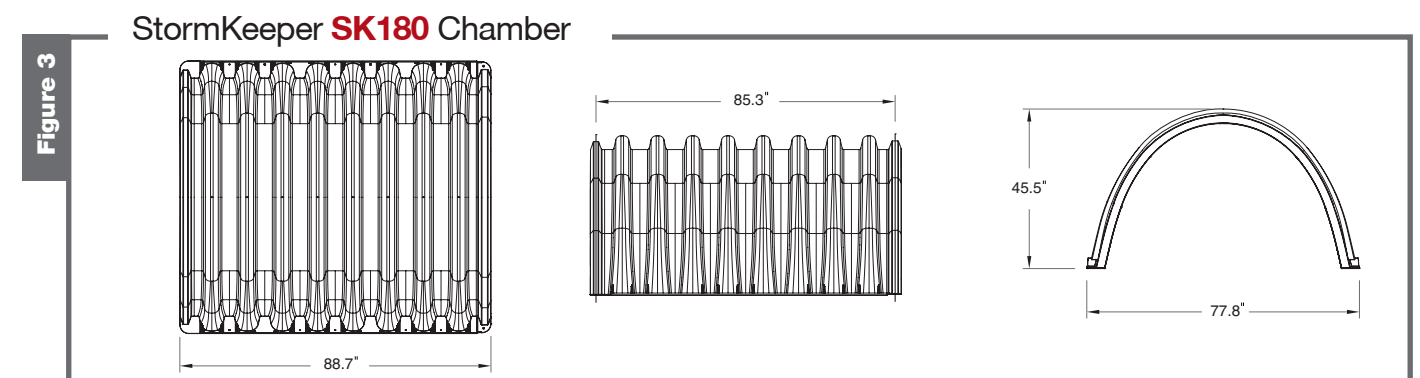
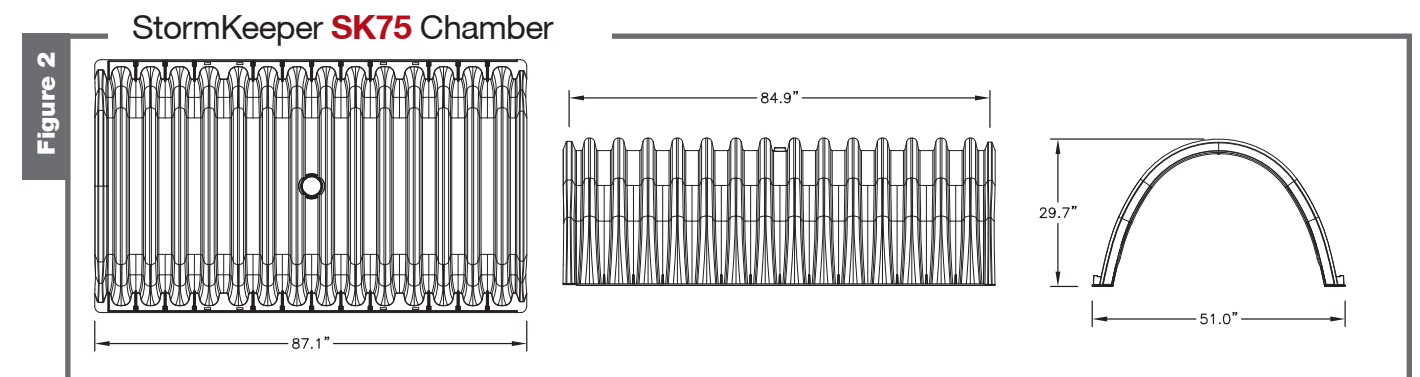
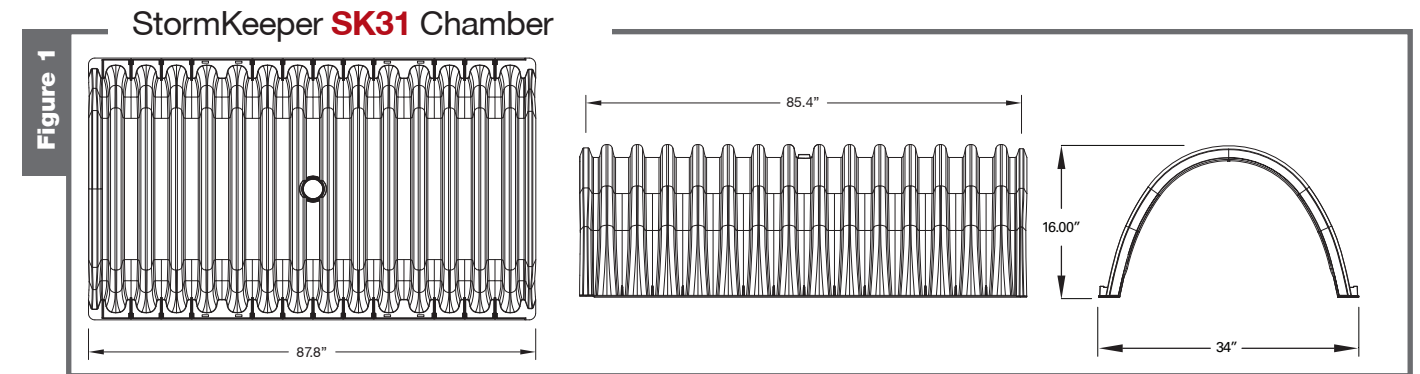

2.0 Product Information



2.4 StormKeeper Chambers

StormKeeper Chambers are extremely versatile and can be configured as necessary to meet the needs of the site. This enables the chambers to be designed to appropriately meet the site conditions and avoid obstacles that may be interfering with a standard system layout. Should a run of chambers need to be interrupted, an end cap can be placed on the chamber end and the row can be restarted after the interruption.

To ease construction and provide easy in-field guidance, the chambers are molded with instructions on the proper direction for installation and how the rows are to be joined. The rows are formed by overlapping the chambers "Start End" corrugation with the next chambers end corrugation. The larger chambers are also provided with handles at the base for easier transport and construction in field conditions. There are no connectors or other special tools required and with the included handles the installation process proceeds smoothly and efficiently with two people.

2.5 End Caps

The end cap is designed to fit over the end of the chamber in order to terminate the chamber row. The end caps are molded with handles to allow easy use and manipulation in the field. The chambers are required to be placed at the end of each row in order to seal the chamber from the aggregate surrounding it. This requires two end caps per row to be ordered with each chamber system. The maximum stub size for each chamber is listed below.

Maximum Stub Size	
StormKeeper SK31	12"
StormKeeper SK75	24"
StormKeeper SK180	30"
StormKeeper SK 290	42"

StormKeeper end caps are constructed using two different methods depending on size. The SK31, SK75, and SK290 End Cap is manufactured utilizing an injection molding process and the SK180 End Cap is a rotomolded part. Like the StormKeeper Chambers, the end caps are also manufactured with polypropylene resins in strict conformance with ASTM F2418.

See **Figure 5, 6, 7, and 8** for further information on the end caps.

2.0 Product Information

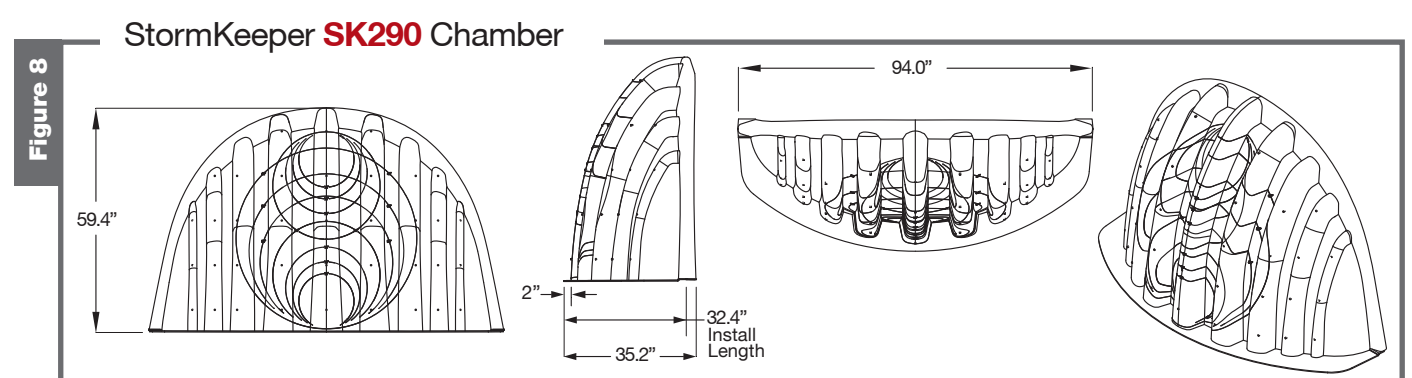
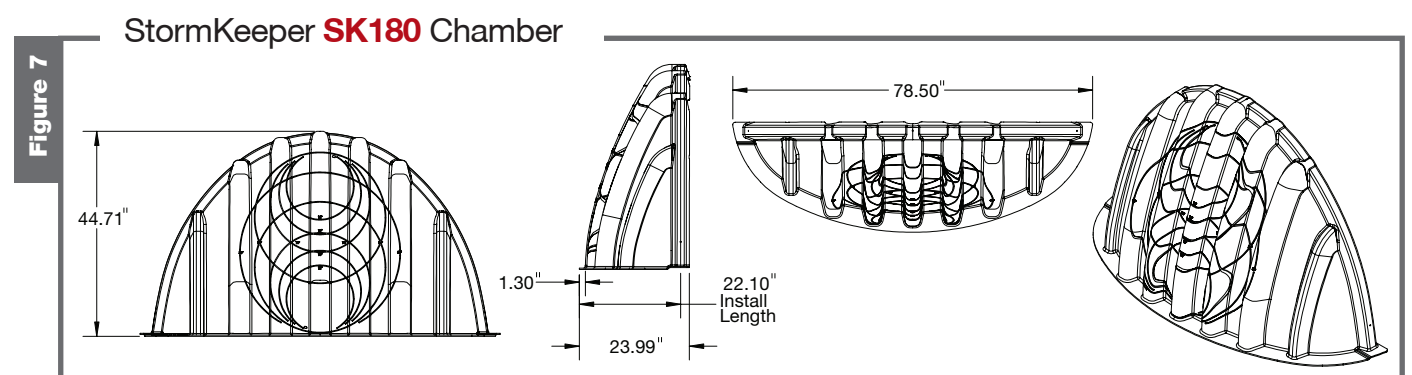
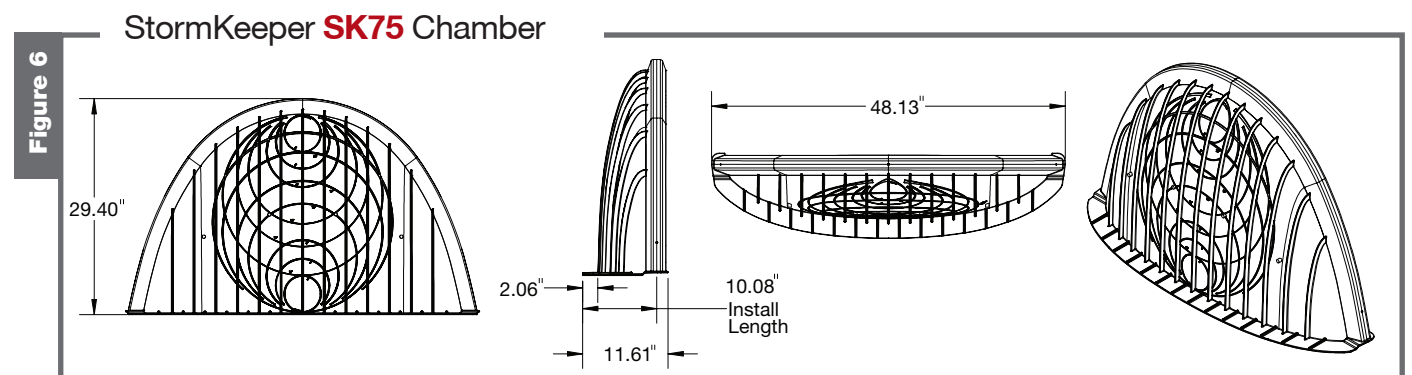
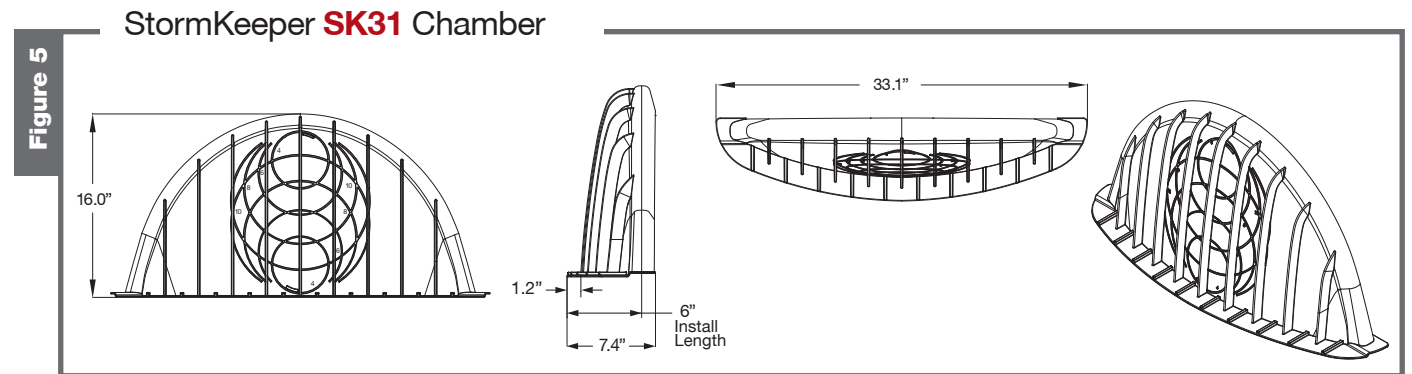

3.0 Structural Design



3.1 Design

Installation of StormKeeper Chambers should be accomplished in accordance with the manufacturer's instructions. When installed correctly, the StormKeeper product line is designed to meet or exceed the AASHTO LRFD factors for dead loads (earth fill) and live loads (vehicular traffic). AASHTO vehicular live loads are designated as either a single axle 32kip load or tandem 25kip axle loads. The conservative design is based on additional factors for impact and multiple vehicles.

Three dimensional models for the chambers were created and a Finite Element Analysis (FEA) was utilized to determine required part thickness, weight, and shape to maximize the structural capacity of the product with an optimized profile. The FEA was utilized to determine maximum thrust, moment, local buckling, and deflection, as well as other factors in both short-term and long-term configurations.

As the StormKeeper products are designed for use in normal buried conditions, it is required that any installation under structures such as buildings and parking garages be designed and reviewed by a structural engineer prior to utilization in these conditions.

3.2 Testing

As part of the design and evaluation program, StormKeeper chambers have been installed in field conditions to perform a variety of tests, including short-term traffic loading and continuous long-term testing and monitoring. The full scale testing was designed to test the limits of the chambers and provide conclusive evidence that the product performs as designed and intended. Long-term testing of StormKeeper products is ongoing.

3.3 Molding

StormKeeper chambers are constructed of polypropylene resin by injection molding. In addition, the end caps are constructed from polypropylene. The entire system meets the design requirements of the AASHTO LRFD specifications as well as ASTM F2787. The injection molding of the chambers provides a highly repeatable process for maintaining precise quality control of the parts and several other benefits including:

- Correct minimum wall thickness
- Correct fits for joints and end caps
- Engraved instructions for installation
- Handles on the chambers
- Precise material placement
- Uniform Structural Strength

3.4 Quality Control

StormKeeper chambers are manufactured with strict quality control measures in place. The incoming raw materials are routinely tested to ensure compliance with the minimum requirements of the resin for processing and end product performance. The chamber properties are tested at regular intervals to ensure proper performance when installed in accordance with the manufacturer's instructions.

4.0 Subsurface Foundation Requirements



4.1 Foundation Requirements

The soil on which the StormKeeper system is constructed must have adequate bearing capacity to support the system. The native soils should be able to maintain the bearing capacity when water has infiltrated the soils underlying the subsurface system as well. If there is inadequate bearing capacity of the native soil, it will be necessary to overexcavate the unsuitable material and provide additional bedding thickness. The bedding must be clean, crushed, angular stone placed between the subgrade soils and the bottom of the chambers.

Increasing dead load (fill) placed over the chamber system requires greater bearing capacity from the subgrade. Additional bedding thickness may be needed to dissipate these pressure demands to accommodate the subgrade capacities.

Table 1 for the SK31 and SK75, and **Table 2** for the SK180 and SK290 identify the minimum bedding depth for cover height and subgrade bearing capacity combinations.

If soils that are weaker than 2,000 pounds per square foot of bearing capacity are encountered, a geotechnical engineer should evaluate and make recommendations for installation of the system and required foundation preparation.

4.2 Chamber Spacing

The minimum spacing for the SK31 and SK75 chamber is 6", 8" for the SK180, and 9" for the SK290. The spacing may be increased as necessary to mitigate the effects of weaker native subgrade soils or to reduce the amount of additional bedding required under the chambers.

4.0 Subsurface Foundation Requirements



SK31 and SK75 Bedding Depth Requirements (inches)

Table 1: Chamber Cover ht. (ft) vs. Minimum Required Bearing Capacity of Native Soil Subgrade (ksf). Grid with columns for cover heights (4.1-2.0) and rows for bedding depths (1.5-8.0).

SK180 and SK290 Bedding Depth Requirements (inches)

Table 2: Chamber Cover ht. (ft) vs. Minimum Required Bearing Capacity of Native Soil Subgrade (ksf). Grid with columns for cover heights (4.1-2.0) and rows for bedding depths (2.0-8.0).

5.0 Installed Storage Volumes for StormKeeper Chambers



5.1 Stage Storage

In order for a hydrograph to be properly routed through any detention system, it is necessary to know the stage vs. storage parameters of the system. Table 3 below, shows the stage storage of a typical SK31 chamber installation with minimum bedding stone of 6". If a deeper bedding is required, then additional storage would be available in that stone base as well. A spreadsheet for determining the installed volume of a chamber system is available to facilitate the calculations required for routing the storm through the underground chamber system. The storage in the installed system assumes a 40% stone porosity. Table 4 below provides the same information for the SK75 chamber. Table 5 below provides the same information for the SK180 chamber, but starts with the minimum bedding of 9".

SK31 Stage Storage

Table 3: SK31 Stage Storage table with columns: Depth (in), Chamber Volume (cf), Cumulative Volume (cf), 68Depth (in), Chamber Volume (cf), Cumulative Volume (cf).

SK180 Stage Storage

Table 5: SK180 Stage Storage table with columns: Depth (in), Chamber Volume (cf), Cumulative Volume (cf), 68Depth (in), Chamber Volume (cf), Cumulative Volume (cf).

SK75 Stage Storage

Table 4: SK75 Stage Storage table with columns: Depth (in), Chamber Volume (cf), Cumulative Volume (cf), 68Depth (in), Chamber Volume (cf), Cumulative Volume (cf).

SK290 Stage Storage

Table 6: SK290 Stage Storage table with columns: Depth (in), Chamber Volume (cf), Cumulative Volume (cf), 68Depth (in), Chamber Volume (cf), Cumulative Volume (cf).

6.0 Required Materials for Installation



6.1 Chamber Row Separation

The SK31 and SK75 are both designed to have a minimum of 6" of spacing between each chamber with the footing of each chamber being parallel to the one next to it. Wider spacing is acceptable and will increase the storage with the additional stone voids as well as spreading the load on the native subgrade material. The SK180 is designed to have a minimum spacing of 8" between the chambers and has the same requirements. The SK290 utilizes 9" between adjacent chambers.

6.2. Stone Bedding

Stone and aggregate between and under the chambers must be clean, crushed, and angular. The acceptable stone gradations and materials that may be used are shown in **Table 6**.

Figures 9 with **Table 7** depicts a typical installation cross section for the SK31, SK75, SK180, and the SK290 chambers respectively.

Acceptable Backfill Requirements

Table 6

Fill Material Location	Material Description	AASHTO Designation	Compaction Requirements
[D] Final Backfill Fill material for Layer D starts at the top of the C layer to the bottom of the pavement or to the finished grade of an unpaved surface. The pavement subbase may be part of the final backfill.	Any backfill which provides adequate subgrade for the project per the engineer's plans. Plans shall indicate subgrade requirements.	N/A	Subgrade will be placed and compacted to the requirements as shown on the site plans.
[C] Initial Backfill Material for layer C starts at the top of the embedment zone (layer B) and continues above the top of the chamber as shown in Figures 4 and 5. The pavement subbase may be part of the initial backfill layer.	Well graded granular material, <35% fines. Most pavement subbase materials can be used in this layer.	AASHTO M45 A-1, A-2-4, A-3 AASHTO M43 3, 357, 4, 467, 5, 56, 57, 6, 67, 68, 7, 78, 8, 89, 9, 10	Compaction will not begin until a minimum of 12" of material is placed over the chambers. Additional layers shall be compacted in 6" lifts to a minimum 95% Standard Proctor density. Roller gross vehicle weight not to exceed 12,000 lbs. Dynamic force not to exceed 20,000 lbs.
[B] Embedment Stone Embedment stone will surround the chambers and extends from the top of the bedding stone (layer A) to the bottom of the fabric layer.	3/4" to 2" clean crushed angular stone.	AASHTO M43 3, 357, 4, 467, 5, 56, 57	No compaction required.
[A] Bedding Stone Bedding stone extends from the subgrade to the foot of the chambers.	3/4" to 2" clean crushed angular stone.	AASHTO M43 3, 357, 4, 467, 5, 56, 57	Placed in 9" maximum lifts and compacted with a vibratory roller or plate compactor to achieve a 95% Standard Proctor density.

Note:

Recycled concrete structural backfill is appropriate use as bedding and embedment stone provided: (1) the gradation requirements are met, (2) ASTM D2488 angular or subangular classifications are met, (3) material hardness testing per AASHTO T96 shows a maximum loss that does not exceed 40%, and (4) sufficient freeze-thaw resistance is provided as determined in accordance with AASHTO T104 when a maximum loss does not exceed 12% after 5 cycles in magnesium sulfate.

6.0 Required Materials for Installation

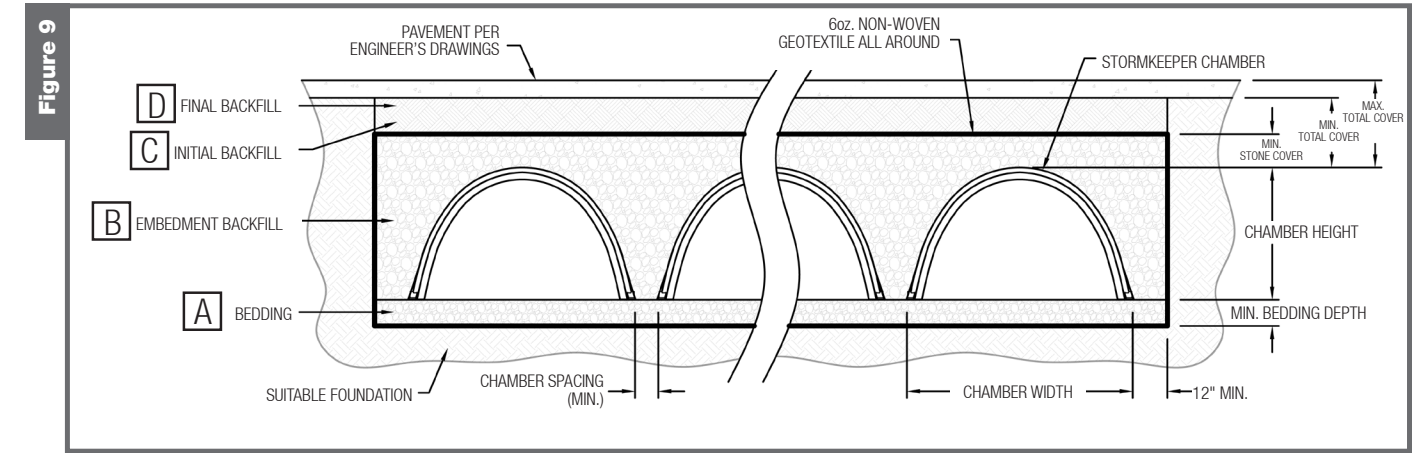

Table 7

Chamber Model	Chamber Width	Chamber Height	Chamber Length	Chamber Lay Length	Minimum Chamber Spacing	Minimum Bedding Depth	Minimum Stone Cover	Minimum Total Cover	Maximum Cover
SK31	33.9"	15.9"	87.8"	85.4"	6"	6"	6"	18"	8'
SK75	51"	30"	87.1"	84.9"	6"	6"	6"	18"	8'
SK180	78"	45.5"	88.7"	85.3"	8"	9"	11.5"	18"	8'
SK290	100.5"	59.5"	51.8"	48.3"	9"	9"	12"	24"	8'

6.0 Required Materials for Installation



6.3 Geotextile

The standard detail (Figures 9) shows non-woven geotextile fabric wrapped around the embedment stone. This is placed to eliminate soil migration between the in-situ material and the embedment material while allowing water to infiltrate into the surrounding soil. The geotextile should surround the clean, crushed aggregate. The overlap of the geotextile should be accomplished as shown in **Figure 10**.

6.4 Types of Backfill Required

Table 6, Figures 9 and Table 7 indicates the appropriate locations and types of backfill required for the installation of the chamber system. The material above the clean, crushed, angular backfill used to envelop the chambers (layer D) can be as specified by the engineer to provide adequate sub-base for the overlying structures. Minimum and maximum fill requirements are shown in **Figures 9**.

Table 6 provides details on backfill and compaction requirements.

Figure 10

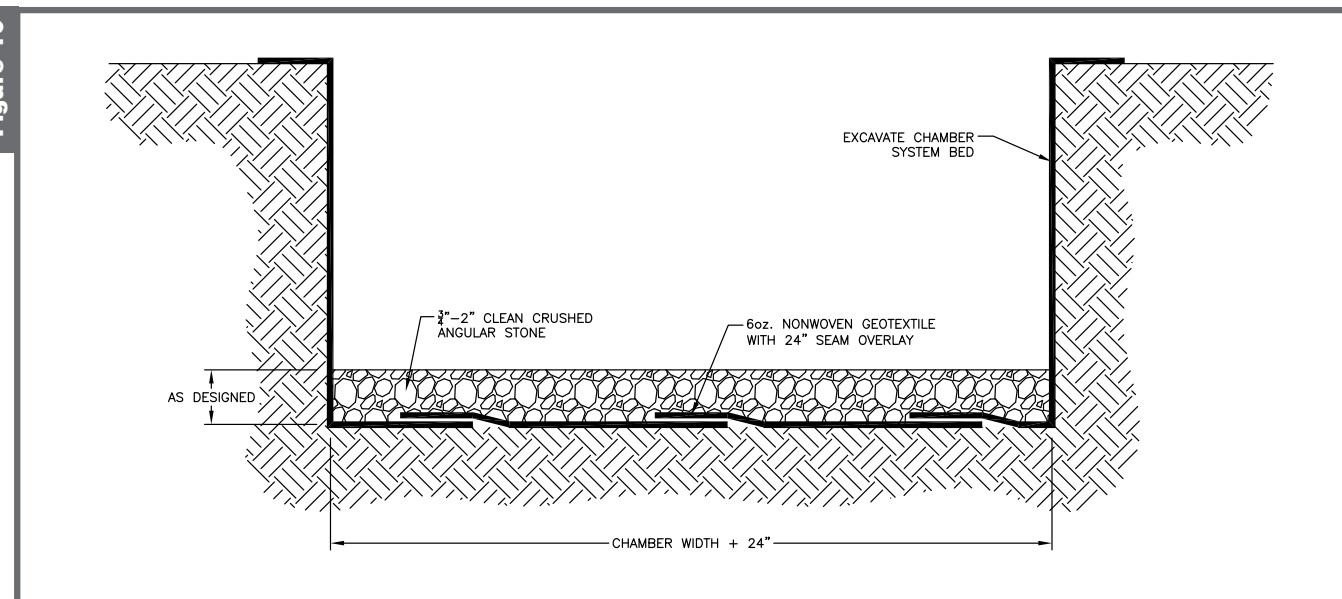

7.0 Stormwater Flow Into Chambers



There are various ways of routing the stormwater from a developed site into the StormKeeper chambers. Below is some guidance on alternatives for accomplishing treatment of the inlet flow. Should more assistance be required, please contact your Lane sales representative or Lane technical support.

7.1 Retention / Detention and the Treatment Train

In addition to the retention / detention of stormwater, one of the functions of an underground system is the treatment of stormwater for water quality. When properly designed, the StormKeeper system can be combined with other stormwater treatment devices to provide a multi-tiered treatment approach for water quality, creating a very effective treatment train. The treatment train can consist of up to four levels of treatment for stormwater entering the StormKeeper system including the following:

- Pre-Treatment – a gravity separation device
- StormKeeper Sediment Strip
- Infiltration of stormwater into ground
- Water polishing

7.2 Pre-Treatment

Depending on the location of the project and local regulations, pre-treatment may be required prior to the stormwater entering the system. A pre-treatment device can be used to reduce the pollutant load entering the system. By reducing the load entering the system, the service life of the system can be extended, and sediment, as well as other pollutants, can be captured helping to meet local regulations.

The types of pre-treatment systems can differ in method and effectiveness. Simple systems can potentially provide the level of treatment required based on the sites characteristics and the required

treatment standards of the local regulations. The options vary from a manhole with a sump, gravity separators, hydrodynamic separators, and low impact development methods such as swales and grass strips. One cost effective method of pretreatment is the Lane Enterprises CFT water quality device.

7.3 StormKeeper Sediment Strip

The StormKeeper Sediment Strip™ can provide additional treatment for stormwater quality and enhance the removal of Total Suspended Solids.

The Sediment Strip is a row of StormKeeper chambers with the appropriate geotextile fabrics connected to a manhole. The row of chambers in the Sediment Strip is an open bottom row with two layers of woven geotextile directly beneath the chamber to provide for filtration of water leaving the strip and leaving sediment and other pollutants filtered out and contained within the row. The Sediment Strip has no other outlet than the bottom of the chamber. Therefore water is forced through the filter fabric to provide filtration needed.

The Sediment Strip is designed with a manhole and weir as inlet to the system. The weir allows the initial runoff at the beginning of a storm to enter the Sediment Strip for filtration. Once the weir height is reached, the remaining water flows through the manifold header and is detained in the main body of the StormKeeper chamber system. This enables the Sediment Strip to act as filtration for the first flush off of the site. The manhole with the diversion weir is connected to the Sediment Strip with a short length of HDPE pipe up to 24" in diameter. The other end of the Sediment Strip has an end cap with no outlet. The remaining chambers are connected to a manifold header which is connected to the inlet manhole on the overflow side of the weir.

7.0 Stormwater Flow Into Chambers



Two layers of woven geotextile that meet AASHTO M288 Class 1 requirements are placed between the bottom of the chambers and the stone foundation. This strong fabric allows water to pass through the chamber into the base stone yet keeps sediment and other pollutants within the Sediment Strip. In addition, the fabric provides a strong base for cleaning the system using Jet-Vac sewer cleaning equipment.

Inspection of the Sediment Strip can be accomplished through the diversion manhole or through inspection ports which can be installed throughout the row. The maintenance of the system and cleanout is accomplished through the use of a Jet-Vac process. The amount of sediment detained and the amount

of water which is treated is based on the size of the project, and the age of the system. See **Figure 11** for further detail on the StormKeeper Sediment Strip.

7.4 Water Polishing (Enhanced Treatment)

In some areas, further sediment removal is required beyond what a pretreatment device and Sediment Strip are capable of doing. In these cases, the StormKeeper system can easily be designed to accommodate further treatment either before or after the StormKeeper system. Location of the enhanced treatment is dependent on local regulations and the preferences of the site and design engineer.

Figure 11

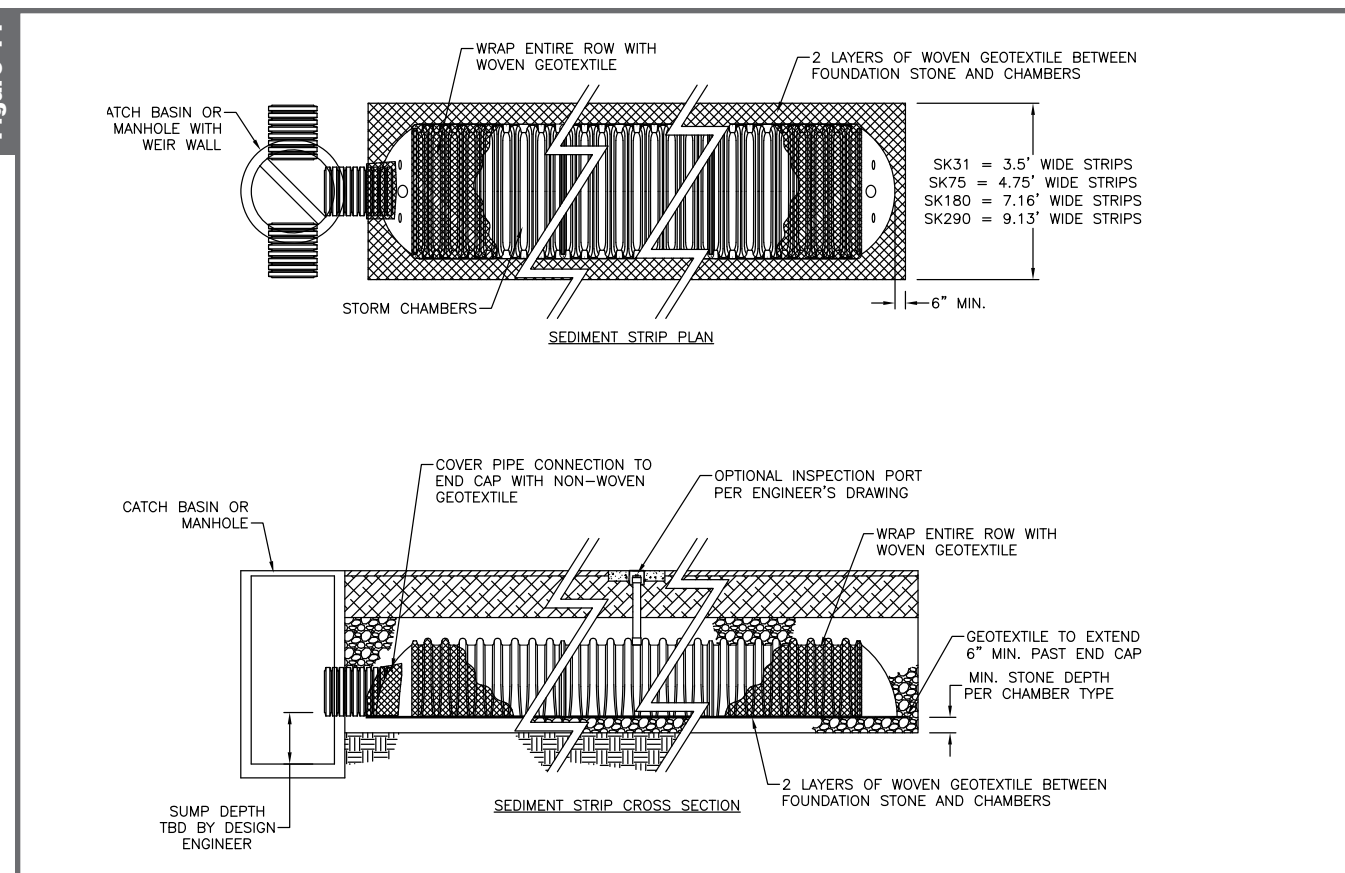

7.0 Stormwater Flow Into Chambers



7.5 Additional Inlet Options

The StormKeeper Sediment Strip™ is not always required or desired in the chamber system. In these situations, the diversion manhole would be unnecessary and only the header system would be used to inlet the stormwater into the chamber bed. See **Figure 12** for various alternatives.

7.6 Perpendicular Inlets

In most installations, inlets to the chambers will be at the chamber row ends with a header system. However, there may be times when an inlet perpendicular to the system is desirable. If this is required, a chamber can be removed from a row and replaced with a tee connected to the inlet pipe. The tee is then connected to the end caps of the chambers adjacent to the tee however, other options are available.

Figure 12

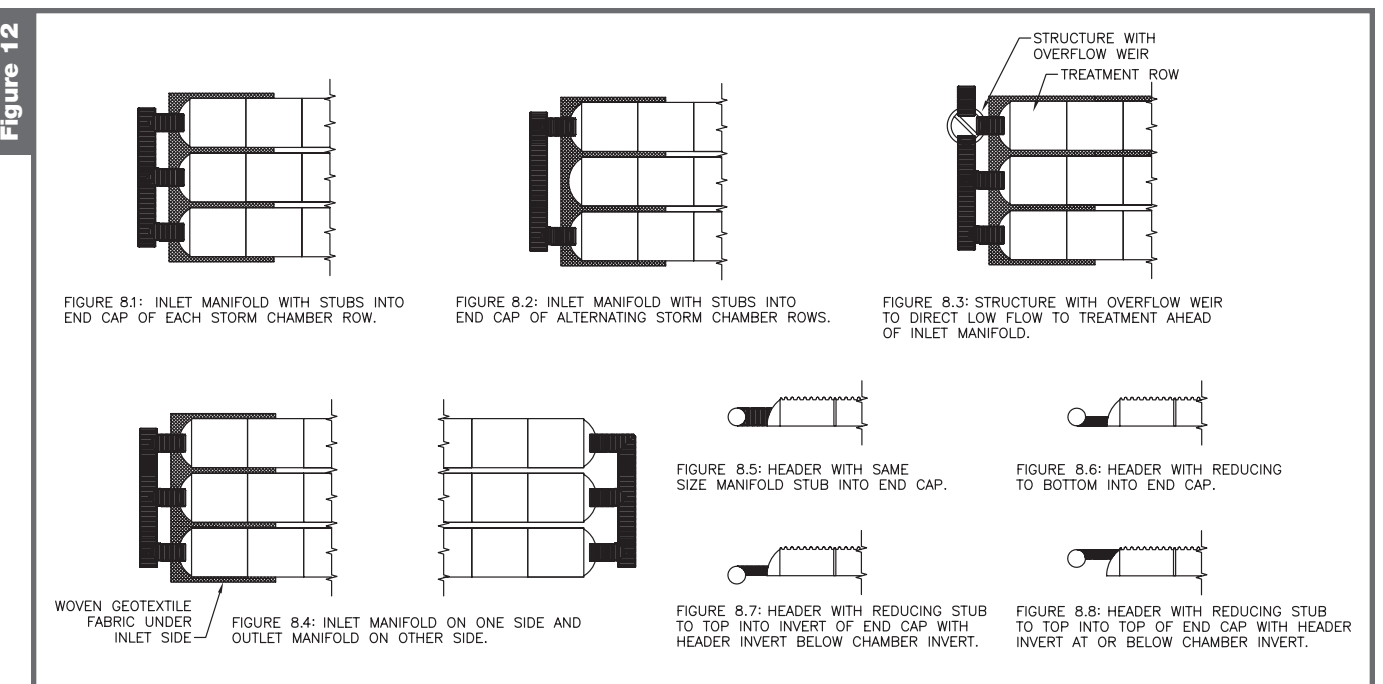

7.0 Stormwater Flow Into Chambers



Table 8

Inlet Pipe Diameter Inches	Allowable Maximum Velocity FPS
4	2.43
6	2.61
8	2.73
10	2.44
12	2.19
15	2.00
18	1.88
24	1.74
30	2.5
36	2.5
42	2.5

7.7 Maximum Inlet Velocity

Water entering the chamber row too fast can scour the foundation stone and lead to foundation issues in the chamber system. In order to prevent this from happening, the maximum velocity should not be greater than what is listed in **Table 8** for specified pipe diameters. Should the velocities be greater than those listed in **Table 8**, then scour prevention should be implemented to assure no loss of stone and subsequent foundation strength. The use of scour control techniques include additional geotextile, riprap or velocity dissipaters. Woven geotextile (ASTHO M288 Class 1) at each inlet row is a simple method to protect the stone from scour and structural loss. **Figure 15** shows typical inlet protection using woven geotextile. Lane includes a length of fabric at each inlet row on all standard drawings for these purposes. (A 15.0' swath for the SK31 and SK75 inlet, and 17.5' for the SK180.)

Should you have any questions or need design assistance with the design of your StormKeeper underground basin, please contact your Lane representative for assistance.

8.0 Storm Release From StormKeeper Chambers

Most installations of chambers are for detention and it will be necessary for there to be some type of outlet structure. An underdrain system may be necessary to completely drain the system. Since the chamber system is underground and utilizes the stone surrounding it for additional storage, the underdrain must be located in or under the foundation stone preferably in a sump area in order to completely drain the system. If a sump is used, it is usually unnecessary to slope the base to provide drainage. **Figures 13 and 14** show alternative underdrain designs which may be required.

One of the benefits of an open bottom chamber system is the ability to infiltrate stormwater back into the ground. A combined outlet approach can help minimize the storage volume needed while providing the ability to infiltrate a good portion of the stormwater runoff and

releasing storms at higher rates through the drainage system. This can be accomplished by providing an outlet structure or pipe with a higher invert within the StormKeeper system. The excess volume is released through outlet structure while the remaining stormwater runoff is infiltrated into the ground.

Outlet pipes or structures should be placed along the perimeter of the StormKeeper system as shown in **Figure 15**. An outlet pipe should be used to penetrate the end cap at the designed invert. The Sediment Strip should not be penetrated by an outlet pipe as that will allow the sediment to escape from the system. If one outlet is not sufficient for the system multiple outlets may be required. It is the design engineers' responsibility to properly design a system which meets the hydraulic and hydrologic requirements of the site to be developed while meeting all applicable laws.

8.0 Storm Release From StormKeeper Chambers



Figure 13

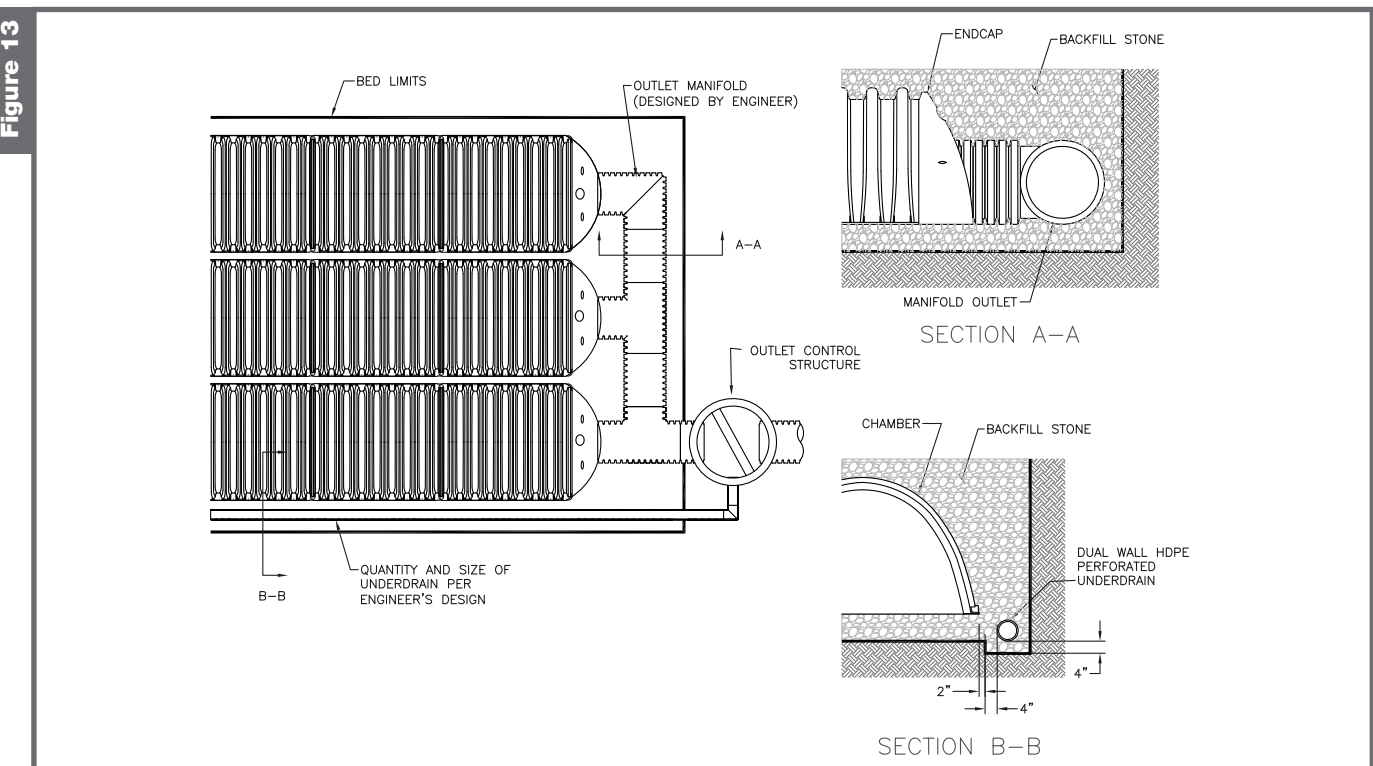
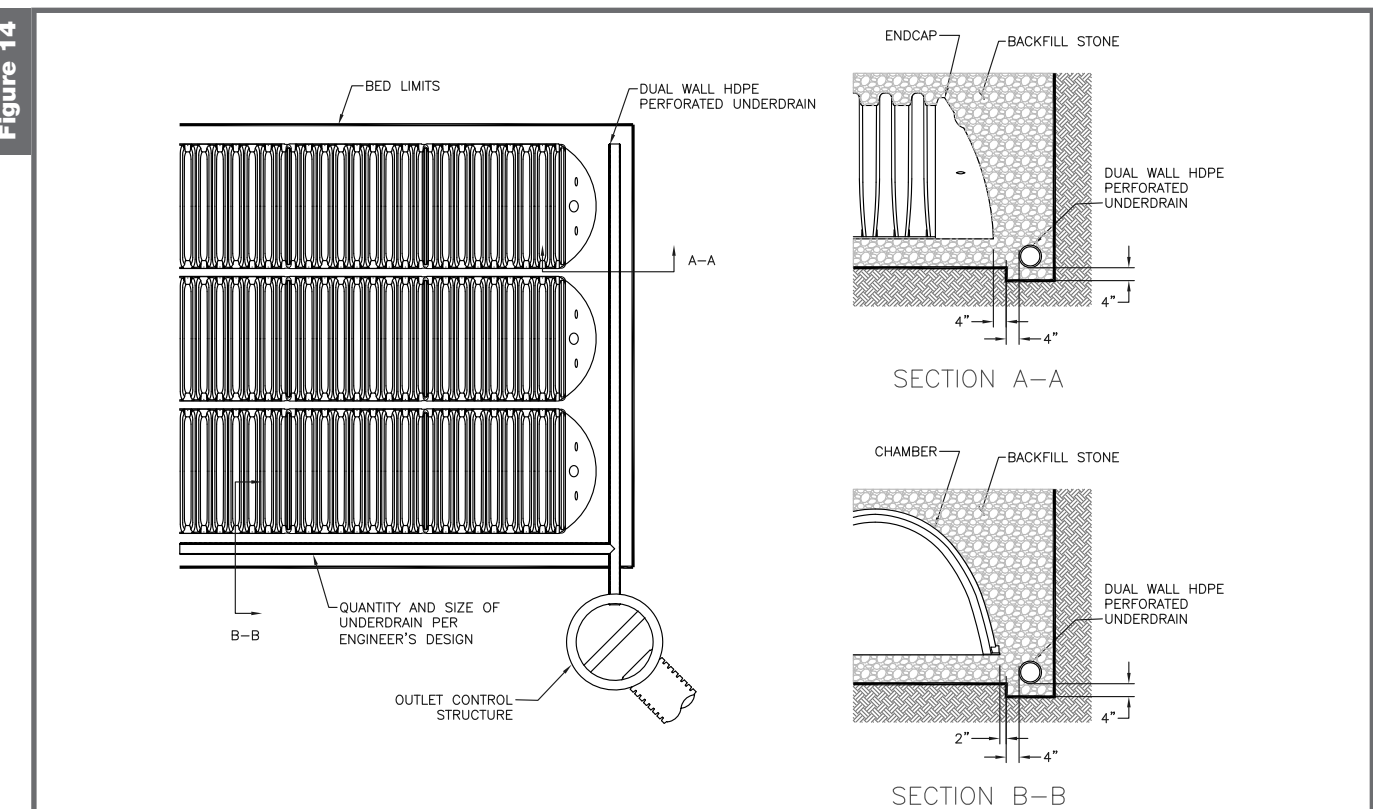

Figure 14



Note: Engineer is to specify the elevations of the piping, stone, and chambers.

9.0 Other Considerations



Figure 15

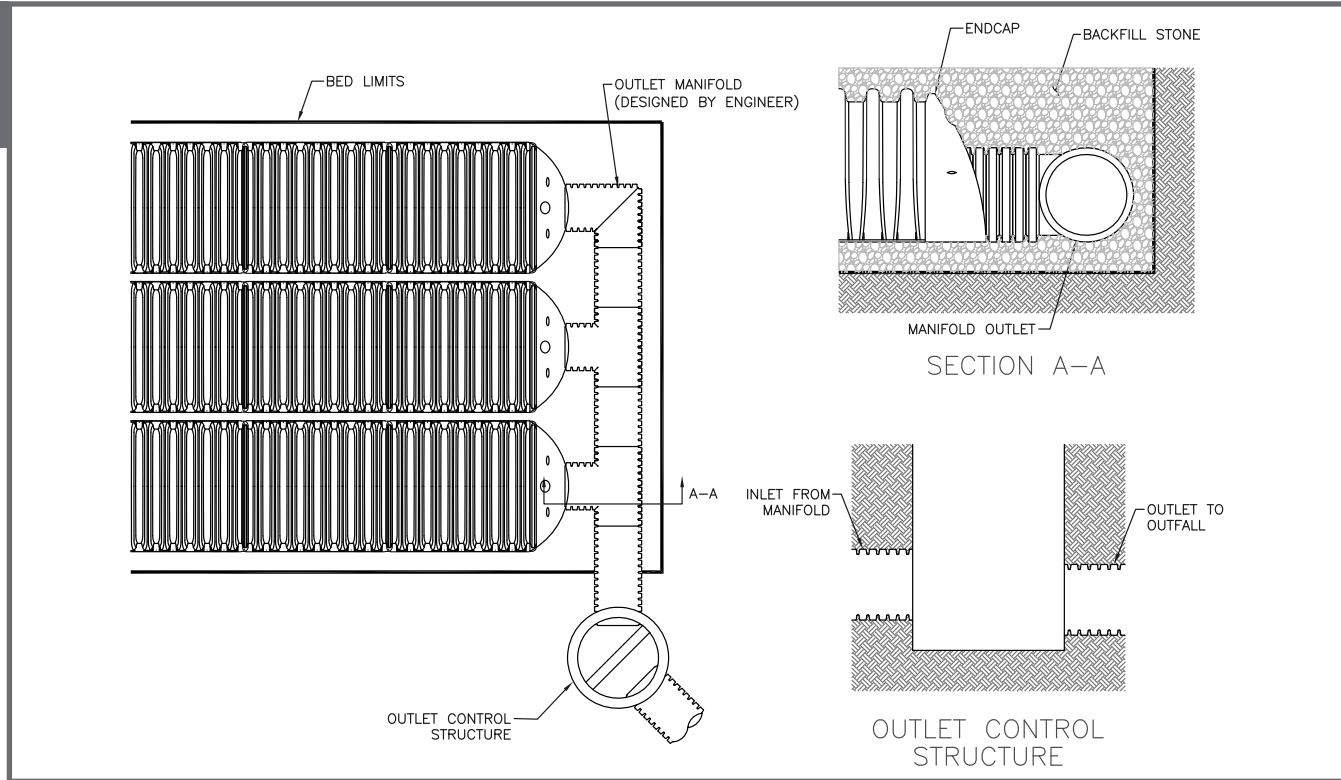

Note: Engineer is to specify the elevations of the piping, stone, and chambers.

9.1 Impermeable Liners

In addition to functioning as an open bottom detention system or retention system infiltrating into the underlying soil, the StormKeeper chamber system can also be designed to be water tight and prevent stormwater from infiltrating into the subsurface. This may be desirable in conditions where the groundwater is contaminated or there is underlying conditions which could be impacted by excess water

infiltration. If it is not desirable for the water to infiltrate into the underlying soil, a thermoplastic geomembrane may be used to provide an impermeable barrier and prevent infiltration into the subsurface.

Liners being installed with StormKeeper chamber system require proper installation in accordance with the manufacturer's installation instructions.

10.0 System Sizing



10.1 Sizing a StormKeeper Chamber System

The design of a detention or retention system is the responsibility of the design engineer for the site being developed. The following steps provide guidance and information necessary for the design of the StormKeeper system. All calculations and design functions must be accomplished and approved by the design engineer. If you need technical assistance with the layout or design of the StormKeeper system, contact your local Lane representative or the Lane technical support at 717.761.8175.

STEP 1: Determine the amount of storage required for the system.

The determination of the volume of water to be stored is the sole responsibility of the design engineer based on local codes, regulations, and design practice.

STEP 2: Determine the number of chambers required.

To determine the number of chambers needed, divide the amount of storage needed by the volume of the chamber selected. The volume of storage available per chamber is provided in **Table 9**.

Table 9

SK31 Storage Volume Per Chamber / End Cap

	Chamber Volume Only	Chamber and Stone Volume Stone Bedding Depths		
		6"	12"	18"
StormKeeper SK31	15.0 cf	31.14 cf	35.14 cf	39.14 cf
StormKeeper SK31 End Cap	.47 cf	5.31 cf	6.39 cf	7.46 cf

Assumes 6" of stone above chambers, 6" of stone between chambers, and 40% stone porosity. End cap volume assumes 12" of perimeter stone.

SK75 Storage Volume Per Chamber / End Cap

	Chamber Volume Only	Chamber and Stone Volume Stone Bedding Depths		
		6"	12"	18"
StormKeeper SK75	46.4 cf	75 cf	81.7 cf	88.4 cf
StormKeeper SK75 End Cap	2.73 cf	13.9 cf	15.6 cf	17.4 cf

Assumes 6" of stone above chambers, 6" of stone between chambers, and 40% stone porosity. End cap volume assumes 12" of perimeter stone.

SK180 Storage Volume Per Chamber / End Cap

	Chamber Volume Only	Chamber and Stone Volume Stone Bedding Depths			
		9"	12"	15"	18"
StormKeeper SK180	113.6 cf	180.0 cf	185.0 cf	190.1 cf	195.2 cf
StormKeeper SK180 End Cap	15.3 cf	53.9 cf	55.9 cf	57.9 cf	60.0 cf

Assumes 11.5" of stone above chambers, 8" of stone between chambers and 40% stone porosity. End cap volume assumes 12" of perimeter stone.

SK290 Storage Volume Per Chamber / End Cap

	Chamber Volume Only	Chamber and Stone Volume Stone Bedding Depths			
		9"	12"	15"	18"
StormKeeper SK290	109.7 cf	164.0 cf	167.9 cf	172.3 cf	175.8 cf
StormKeeper SK290 End Cap	39.6 cf	109.5 cf	116.4 cf	118.3 cf	120.1 cf

Assumes 12" of stone above chambers 8.5" of stone between chambers and 40% porosity. End caps assume 12" of perimeter stone

10.0 System Sizing



STEP 3: Determine the required bed size for the chambers.

To determine the size of the bed, multiply the number of chambers required by the bed area per chamber. The bed area per chamber is provided in the **Table 10** shown below.

Table 10

Bed Area per Chamber	
StormKeeper SK31	23.7 sf
StormKeeper SK75	33.6 sf
StormKeeper SK180	50.9 sf
StormKeeper SK290	39.2 sf

In addition to the bed area calculated, an additional 1' should be added around the chamber bed to provide for working room and backfill of the chambers.

STEP 4: Determine the amount of aggregate required.

To determine the amount of aggregate required, multiply the number of chambers or endcaps by their corresponding stone quantity for the selected bedding depth shown in **Table 11** below.

Table 11

SK31 Amount of Stone per Chamber / End Cap				
	Stone Bedding Depth			
	6"	12"	18"	
StormKeeper SK31	2.5 cy	2.9 cy	3.4 cy	<i>Assumes 6" of stone above, 6" row spacing, and 12" of perimeter stone in front of end caps.</i>
StormKeeper SK31 End Cap	.48 cy	.58 cy	.68 cy	

SK75 Amount of Stone per Chamber / End Cap				
	Stone Bedding Depth			
	6"	12"	18"	
StormKeeper SK75	2.6 cy	3.3 cy	3.9 cy	<i>Assumes 6" of stone above, 6" row spacing, and 12" of perimeter stone in front of end caps.</i>
StormKeeper SK75 End Cap	1.0 cy	1.2 cy	1.4 cy	

SK180 Amount of Stone per Chamber / End Cap					
	Stone Bedding Depth				
	9"	12"	15"	18"	
StormKeeper SK180	6.1 cy	6.6 cy	7.1 cy	7.6 cy	<i>Assumes 11.5" of stone above, 8" row spacing, and 12" of perimeter stone in front of the end caps.</i>
StormKeeper SK180 End Cap	3.6 cy	3.8 cy	3.9 cy	4.1 cy	

SK290 Amount of Stone per Chamber / End Cap					
	Stone Bedding Depth				
	9"	12"	15"	18"	
StormKeeper SK290	5.0 cy	5.4 cy	5.8 cy	6.1 cy	<i>Assumes 12" of stone above, 8.5" row spacing, and 12" perimeter stone in front of end caps.</i>
StormKeeper SK290 End Cap	6.5 cy	6.8 cy	7.2 cy	7.5 cy	

10.0 System Sizing



STEP 5: Calculate the volume of the excavation required.

The volume of excavation required per chamber is shown in **Table 12**. In addition, the 1' required around the perimeter must be included. For each additional foot of cover, the excavation will be increased as shown in **Table 13**.

Table 12

	Stone Bedding Depth			
	6"	12"	18"	
StormKeeper SK31	2.1 cy	2.5 cy	3.0 cy	<i>Assumes 6" of separation between chamber rows, 12" of perimeter stone in front of end caps, and 18" of cover. Should depth of cover exceed 18", the volume of excavation will increase accordingly.</i>
StormKeeper SK31 End Cap	.49 cy	.59 cy	.69 cy	

SK75 Volume of Excavation Required Per Chamber / End Cap				
	Stone Bedding Depth			
	6"	12"	18"	
StormKeeper SK75	5.6 cy	6.2 cy	6.8 cy	<i>Assumes 6" of separation between chamber rows, 12" of perimeter stone in front of end caps, and 18" of cover. Should depth of cover exceed 18", the volume of excavation will increase accordingly.</i>
StormKeeper SK75 End Cap	1.5 cy	1.6 cy	1.8 cy	

SK180 Volume of Excavation Required Per Chamber / End Cap					
	Stone Bedding Depth				
	9"	12"	15"	18"	
StormKeeper SK180	12.3 cy	12.8 cy	13.3 cy	13.7 cy	<i>Assumes 8" of separation between chamber rows, 12" of perimeter in front of end caps and 24" of cover. Should depth of cover exceed 24", the volume of excavation will increase accordingly.</i>
StormKeeper SK180 End Cap	4.9 cy	5.1 cy	5.3 cy	5.5 cy	

SK290 Volume of Excavation Required Per Chamber / End Cap					
	Stone Bedding Depth				
	9"	12"	15"	18"	
StormKeeper SK290	8.5 cy	9.0 cy	9.5 cy	10.0 cy	<i>Assumes 8.5" between rows 12" perimeter stone and 24" of min cover. If greater than 24" of cover excavation numbers should be increases.</i>
StormKeeper SK290 End Cap	7.7 cy	8.2 cy	8.7 cy	9.2 cy	

STEP 6: Calculate the amount of nonwoven geotextile required.

The bottom, sides, and top of the embedment stone must be covered with a 6 oz nonwoven geotextile. The area to be covered would be the area of the bottom + the area of the top + the area of the sidewalls. Allowances should be made to include the 2' overlap required at all geotextile joints.

Table 13

	Volume of Excavation for each additional foot of cover
StormKeeper SK31	23.7 cf
StormKeeper SK75	33.6 cf
StormKeeper SK180	50.9 cf
StormKeeper SK290	39.2 cf

STEP 7: Determine the number of end caps needed.

Each row of chambers requires two end caps. If a row is terminated and restarted, two additional end caps will be required on that row.

STEP 8: Determine the size of the headers needed.

Header size should be determined based on the amount of flow entering the stormkeeper system. A header of large enough diameter to accommodate the flow rate required should be selected. Stub sizes should be based on an even distribution of flow into each lateral.

Visit storm-storage.com to utilize the StormKeeper Chamber Design Tool.

STORMKEEPER™

STORMWATER CHAMBER

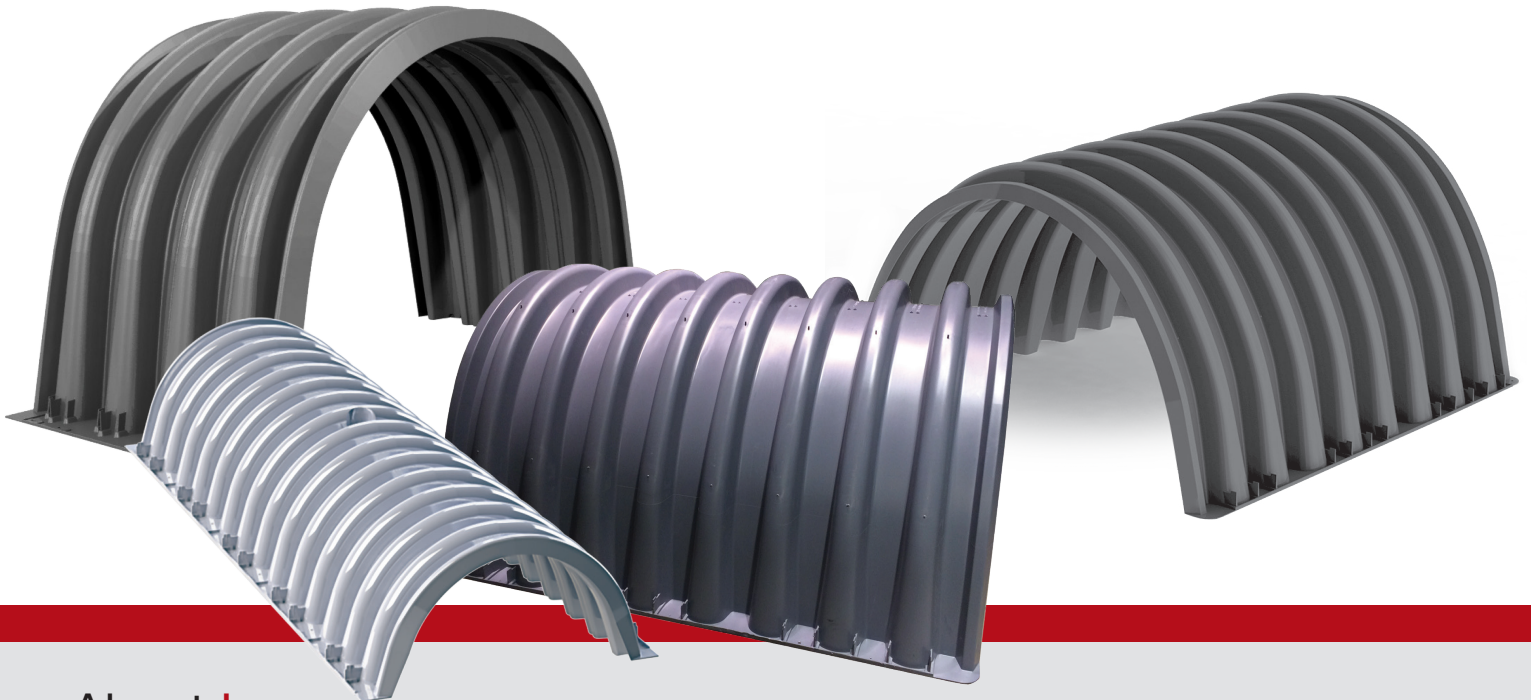

About Lane

As a full-line manufacturer of corrugated metal and plastic drainage products, Lane Enterprises, Inc. operates plants throughout the Northeastern, Mid-Atlantic, and South-Central states producing various types of buried structures for the construction industry.

For nearly 90 years, Lane has partnered with contractors, engineers, and municipalities to supply reliable products that provide the highest levels of service life, strength, versatility, and economy. Our focus on quality products, responsive customer service, and technical expertise has established a long, proven history of successful partnerships within the industries we serve.



Lane Enterprises, Inc.
3905 Harzdale Drive, Suite 514
Camp Hill, PA 17011
P: 717.761.8175 • F: 717.761.5055
lane-enterprises.com/StormKeeper

© 2023 Lane Enterprises
RAKZID-04/23-AA